













BRAKE SYSTEM

GENERAL DESCRIPTION



1. Care must be taken to replace each part properly as it could affect the performance of the brake system and result in a driving hazard. Replace the parts with parts of the same part number or equivalent.
2. It is very important to keep parts and the area clean when repairing the brake system.
3. If the vehicle is equipped with a mobile communication system, refer to the precaution in the IN section.

PREPARATION

SST (SPECIAL SERVICE TOOLS)

	09023-00100	Union Nut Wrench 10 mm	
	09709-29017	LSPV Gauge Set	
	09718-20010	Brake Shoe Return Spring Replacer	
	09737-00010	Brake Booster Push Rod Gauge	
	09751-36011	Brake Line Union Nut 10 x 12 mm Wrench	
	09843-18020	Diagnosis Check Wire	
	09990-00150	ABS Actuator Checker and Sub-harness	
	09990-00163	ABS Actuator Checker Sheet "A"	
	09990-00200	ABS Actuator Checker Sub-harness "C"	w/o TRAC
	09990-00210	ABS Actuator Checker Sub-harness "E"	
	09990-00250	ABS Actuator Checker Sub-harness "G"	w/ TRAC
	09990-00280	ABS Actuator Checker Sub-harness "H"	w/ TRAC
	09990-00330	TRAC Actuator Air Bleed Wire	w/ TRAC

RECOMMENDED TOOLS

	09082-00050 TOYOTA Electrical Tester Set ◆	
	09905-00013 Snap Ring Pliers ◆	

EQUIPMENT

Torque wrench	
Micrometer	Brake disc
Dial indicator	Brake disc
Vernier calipers	Brake disc

LUBRICANT

Item	Capacity	Classification
Brake fluid	–	SAEJ1703 or FMVSS No.116, DOT 3

TROUBLESHOOTING

Use the table below to help you find the cause of the problem. The numbers indicate the priority of the likely cause of the problem. Check each part in order. If necessary, replace these parts.

	See page																					
		Part Name	Trouble																			
		Brake system (fluid leaks)																			BR-17,22,26,31	
		Brake system (Air in)																				BR-17,22,26,31
		Brake pad (Worn)																				BR-6
		Piston seal (Worn or damaged)																				BR-11
		Brake pedal (freeplay minimal)																				BR-39
		Master cylinder (Faulty)																				BR-10
		Parking brake (Shoe clearance out of adjustment)																				
		Parking brake (Lever travel out of Adjustment)																				
		Parking brake wire (Sticking)																				
		Booster push rod (Out of adjustment)																				BR-16
		Tension or return spring (Faulty)																				BR-35
		Pad (Cracked or distorted)																				BR-17,22,26,31
		Piston (Stuck)																				BR-17,22,26,31
		Pad (Only)																				BR-17,22,26,31
		Piston (Frozen)																				BR-17,22,26,31
		Booster system (Vacuum leaks)																				BR-7
		Pad support plate (Loose)																				BR-17,22,26,31
		Installation bolt (Loose)																				BR-17,22,26,31
		Sliding pin (Worn)																				BR-17,22,26,31
		Disc (Scored)																				BR-17,22,26,31
		Pad (Dirty)																				BR-17,22,26,31
		Pad (Glazed)																				BR-17,22,26,31
		Anti-squeal shim (Damaged)																				BR-17,22,26,31
		Hold-down spring (Damaged)																				BR-35

Low pedal or spongy pedal	1	2	3																				
Brake drag				1	11	4	2	3	9	8	5	6		7	10								
Brake pull											5	1	2	3						4			
Hard pedal but brake inefficient	1	2	3						8	4		5		9						7	6		
Noise from brakes									8	1						4	2	5	3	6	7	9	10

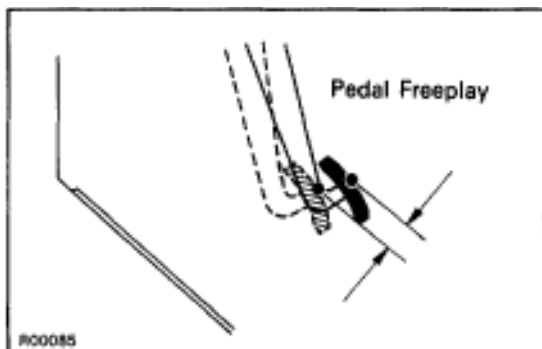
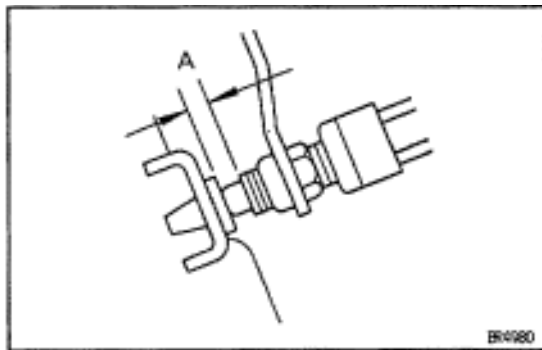
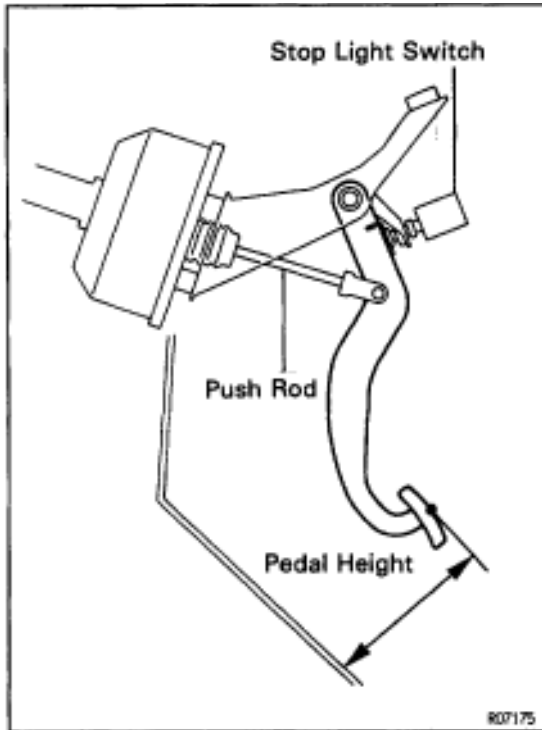

CHECK AND ADJUSTMENT BRAKE PEDAL CHECK AND ADJUSTMENT

1. CHECK THAT PEDAL HEIGHT IS CORRECT

Pedal height from dash panel:

154.2–164.2 mm (6.07–6.46 in.)

If the pedal height is incorrect, adjust it.

2. IF NECESSARY, ADJUST PEDAL HEIGHT

- Remove the lower instrument panel and finish panel.
 - Disconnect the connector from the stop light switch.
 - Loosen the stop light switch lock nut and remove the stop light switch.
 - Loosen the push rod lock nut.
 - Adjust the pedal height by turning the pedal push rod.
 - Tighten the push rod lock nut.
- Torque: 25 N·m (260 kgf·cm, 19 ft·lbf)**
- Install the stop light switch and turn it until it lightly contacts the pedal stopper.
 - Turn the stop light switch back one turn.
 - Check the clearance (A) between stop light switch and pedal.

Clearance:

0.5–2.4 mm (0.02–0.09 in.)

- Tighten the stop light switch lock nut.
- Connect the connector to the stop light switch.
- Check that the stop lights come on when the brake pedal is depressed, and go off when the brake pedal is released.
- After adjusting the pedal height, check the pedal free-play.
HINT: If clearance (A) between the stop light switch and the brake pedal stopper has been adjusted correctly, the pedal freeplay will meet the specifications.
- Install the lower instrument panel and finish panel.

3. CHECK PEDAL FREEPLAY

- Stop the engine and depress the brake pedal several times until there is no more vacuum left in the booster.
- Push in the pedal by hand until the beginning of the second point of resistance is felt, then measure the distance, as shown.

Pedal freeplay:

1–6 mm (0.04–0.24 in.)

If incorrect, check the stop light switch clearance. And if the clearance is OK, then troubleshoot the brake system.

HINT: The freeplay to the 1st point of resistance is due to the play between the clevis and pin. It is 1–3 mm (0.04–0.12 in.) on the pedal.

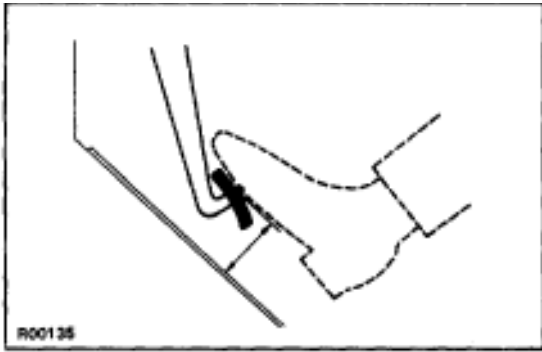

4. CHECK PEDAL RESERVE DISTANCE

Release the parking brake.

With the engine running, depress the pedal and measure the pedal reserve distance, as shown.

Pedal reserve distance at 490 N (50 kgf, 110.2 lbf):

w/o TRAC: More than 72 mm (2.83 in.)

w/ TRAC: More than 70 mm (2.76 in.)

If the reserve distance is incorrect, troubleshoot the brake system.

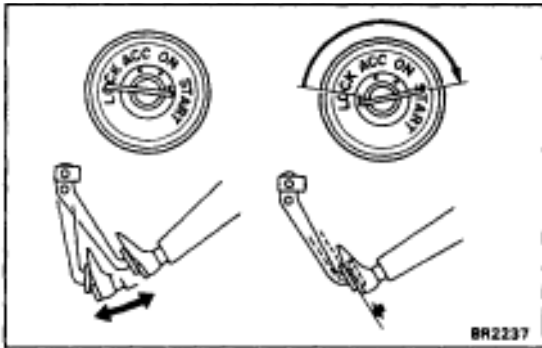

BRAKE BOOSTER OPERATIONAL TEST

1. OPERATING CHECK

- Depress the brake pedal several times with the engine off and check that there is no change in the pedal reserve distance.
- Depress the brake pedal and start the engine. If the pedal goes down slightly, operation is normal.

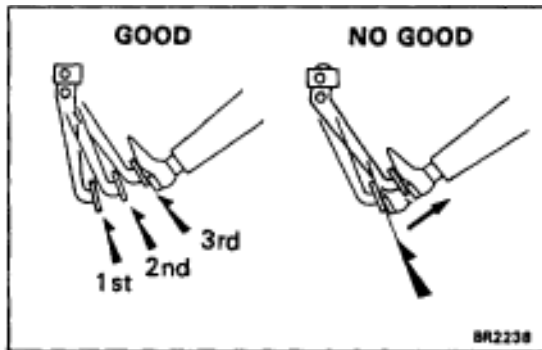

2. AIR TIGHTNESS CHECK

- Start the engine and stop it after 1 or 2 minutes. Depress the brake pedal several times slowly. If the pedal goes down farthest the 1st time, but gradually rises after the 2nd or 3rd time, the booster is air tight.
- Depress the brake pedal while the engine is running, and stop the engine with the pedal depressed. If there is no change in the pedal reserve travel after holding the pedal for 30 seconds, the booster is air tight.

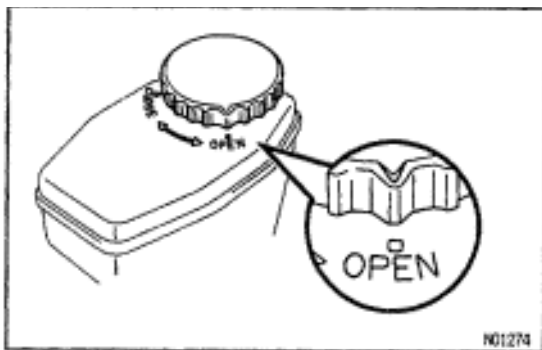

BRAKE SYSTEM BLEEDING

HINT: If any work is done on the brake system or if air in the brake lines is suspected, bleed the system of air.

NOTICE: Do not let brake fluid remain on painted surfaces. Wash it off immediately.

1. REMOVE RESERVOIR CAP

Turn the reservoir cap to the "open" side and remove it.

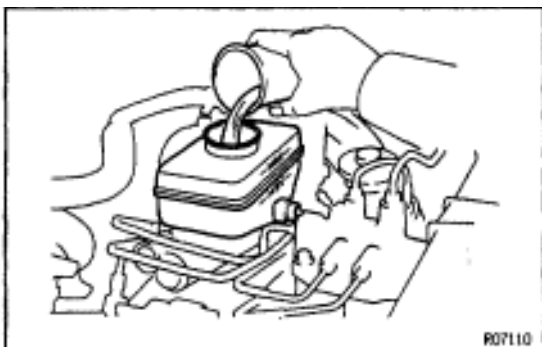

2. FILL RESERVOIR WITH BRAKE FLUID

Fluid:

SAE J1703 or FMVSS NO.116 DOT3

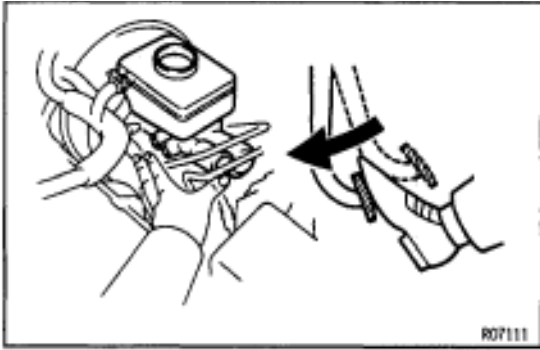

3. BLEED MASTER CYLINDER

HINT: If the master cylinder has been disassembled or if the reservoir becomes empty, bleed the air from the master cylinder.

- (a) Disconnect the brake lines from the master cylinder.
- (b) Slowly depress the brake pedal and hold it.

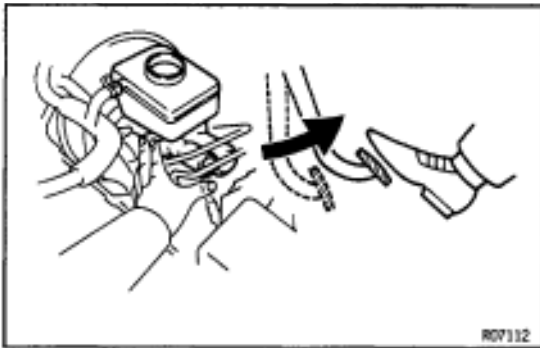

- (c) Block off the outer holes with your fingers, and release the brake pedal.
- (d) Repeat (b) and (c) 3 or 4 times.

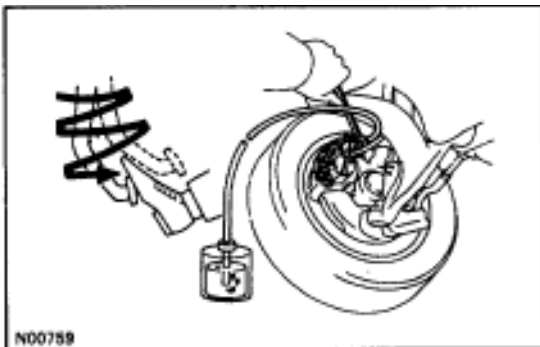

4. BLEED BRAKE LINE

- (a) Connect the vinyl tube to the brake caliper.
- (b) Depress the brake pedal several times, then loosen the bleeder plug with the pedal held down.
- (c) At the point when fluid stops coming out, tighten the bleeder plug, then release the brake pedal.
- (d) Repeat (b) and (c) until all the air in the fluid has been bled out.
- (e) Repeat the above procedure to bleed the air out of the brake line for each wheel.

Torque: 11 N·m (110 kgf·cm, 8 ft·lbf)

5. CHECK FLUID LEVEL IN RESERVOIR

Check the fluid level and add fluid if necessary.

Fluid:

SAE J1703 or FMVSS NO.116 DOT3

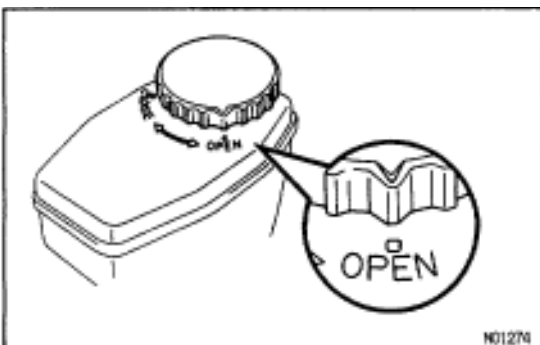

6. INSTALL RESERVOIR CAP

- (a) Align the matchmark on the reservoir cap with the matchmark on the "open" side of reservoir.
- (b) Push down on the reservoir cap and turn it clockwise until it locks.
- (c) Check that the matchmark on the reservoir cap is now aligned with the matchmark on the "close" side of the reservoir.

TRAC CONTROL SYSTEM BLEEDING

HINT: When repairing the brake master cylinder or TRAC system, bleed the air out of the TRAC system.

1. INSPECT BATTERY POSITIVE VOLTAGE

Battery positive voltage:

10-14 V

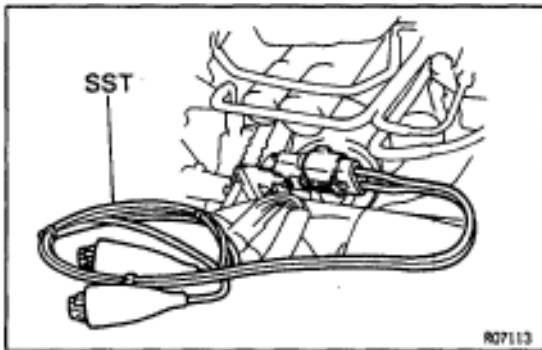

2. BLEED TRACTION CONTROL SYSTEM

(a) Disconnect the connector from the TRAC pump.

(b) Connect SST to the TRAC pump.

SST 09990-00330

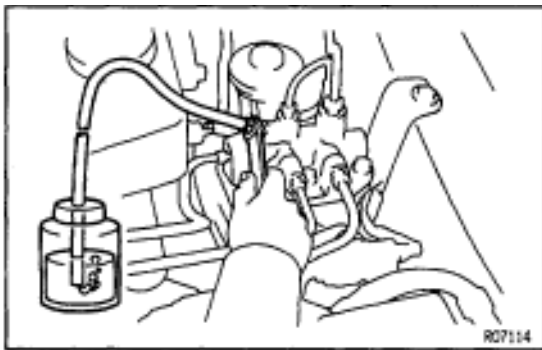

(c) Connect a vinyl tube to the bleeder plug of the TRAC actuator, then loosen the bleeder plug.

(d) Start the engine.

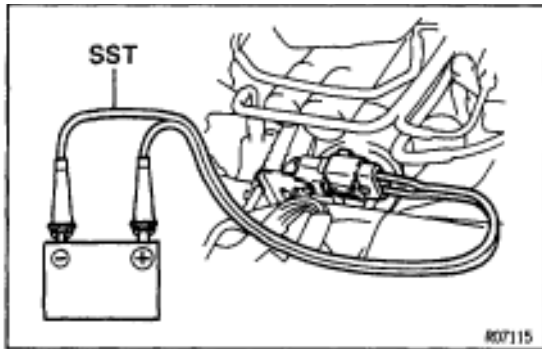

(e) Connect the SST to the battery. Then wait at least 60 seconds before tightening the bleeder plug with the TRAC pump still operating.

Torque: 8.3 N·m (85 kgf·cm, 74 in.·lbf)

(f) After tightening the bleeder plug, keep the TRAC pump operating for approximately 30 seconds.

(g) Install the cap.

3. CHECK FLUID LEVEL IN RESERVOIR

Fluid:

SAE J1703 or FMVSS NO. 116 DOT3

4. CLEAR DIAGNOSTIC TROUBLE CODES

(See page [BR-127](#))

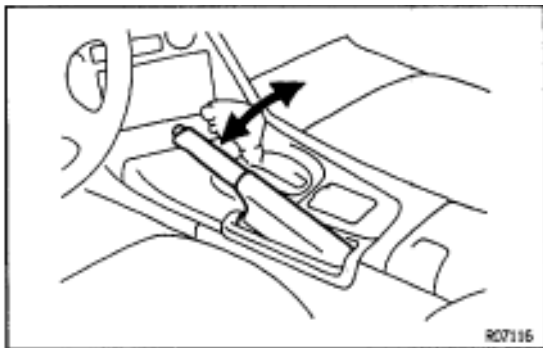

PARKING BRAKE CHECK AND ADJUSTMENT

1. CHECK PARKING BRAKE LEVER TRAVEL

Pull the parking brake lever all the way up, and count the number of clicks.

Parking brake lever travel at 196 N (20 kgf, 44.1 lbf):

5–8 clicks

If incorrect, adjust the parking brake.

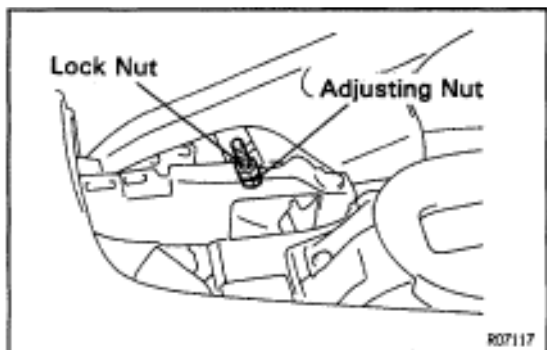

2. IF NECESSARY, ADJUST PARKING BRAKE

HINT: Before adjusting the parking brake, make sure that the rear brake shoe clearance has been adjusted.

For shoe clearance adjustment, see page [BR-39](#).

- (a) Remove the upper console panel.
 - (b) Remove the screw and parking brake hole cover.
 - (c) Using a socket driver and spanner wrench, remove the adjusting lock nut.
 - (d) Turn the adjusting nut until the lever travel is correct.
 - (e) Install the adjusting lock nut.
 - (f) Using a socket driver and spanner wrench, tighten the adjusting lock nut.
- Torque: 5.4 N·m (55 kgf·cm, 48 in·lbf)**
- (g) Install the parking brake hole cover with the screw.
 - (h) Install the upper console panel.

MASTER CYLINDER

MASTER CYLINDER REMOVAL

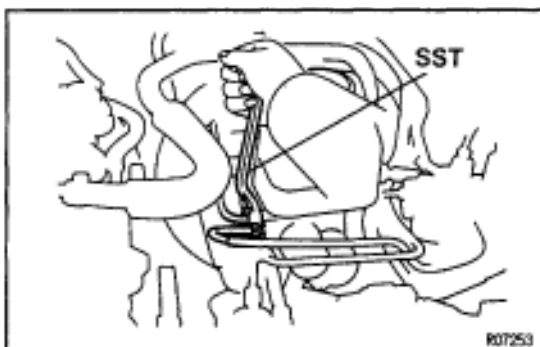
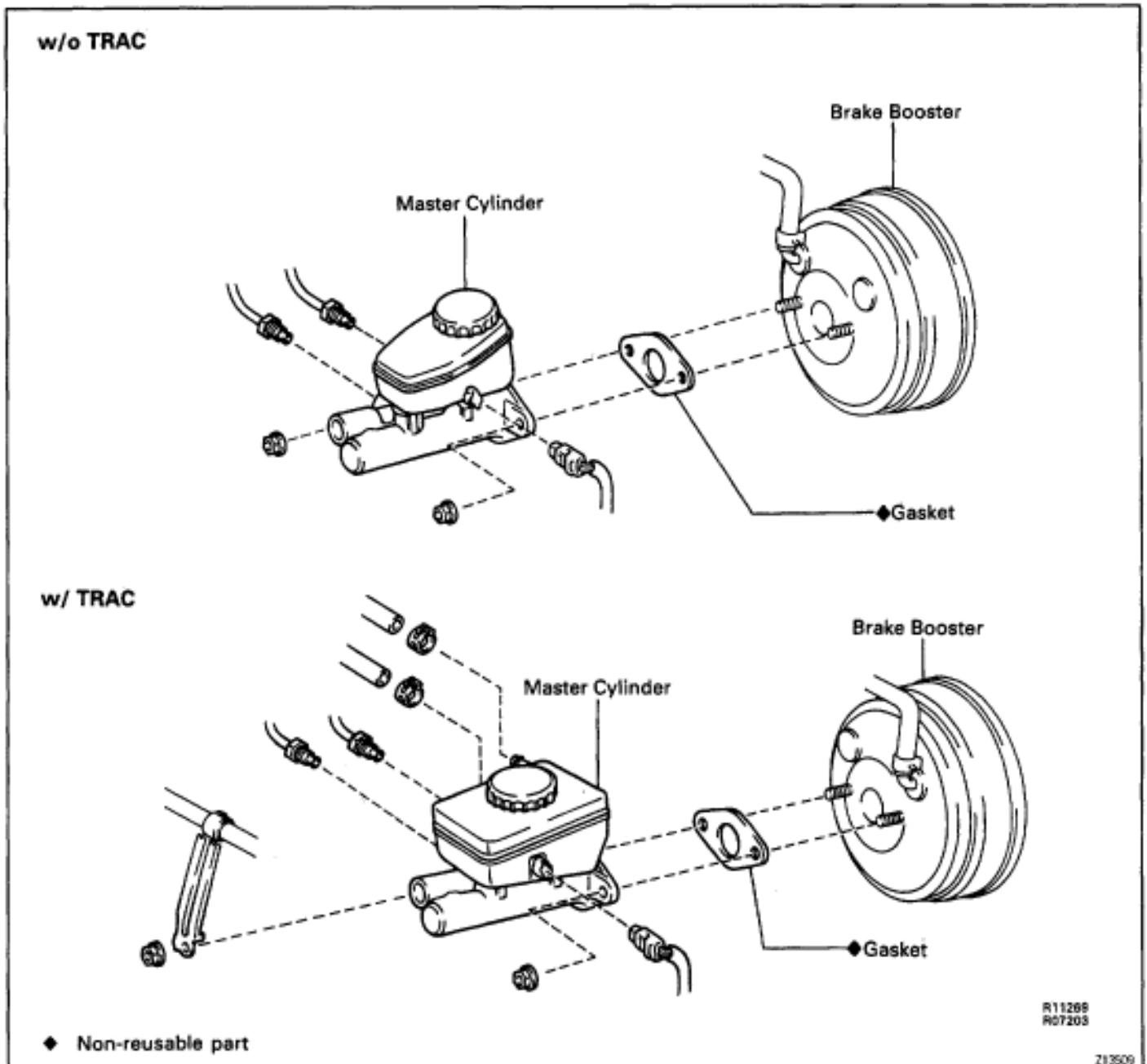

1. **DISCONNECT LEVEL WARNING SWITCH CONNECTOR**
2. **DRAW OUT FLUID WITH SYRINGE**
NOTICE: Do not let brake fluid remain on a painted surface. Wash it off immediately.
3. **DISCONNECT BRAKE LINES**
 Using SST, disconnect the brake lines from the master cylinder.
 SST 09751-36011



4. REMOVE MASTER CYLINDER

- (a) Remove the 2 nuts.
- (b) Remove the master cylinder and gasket from the brake booster.

COMPONENTS

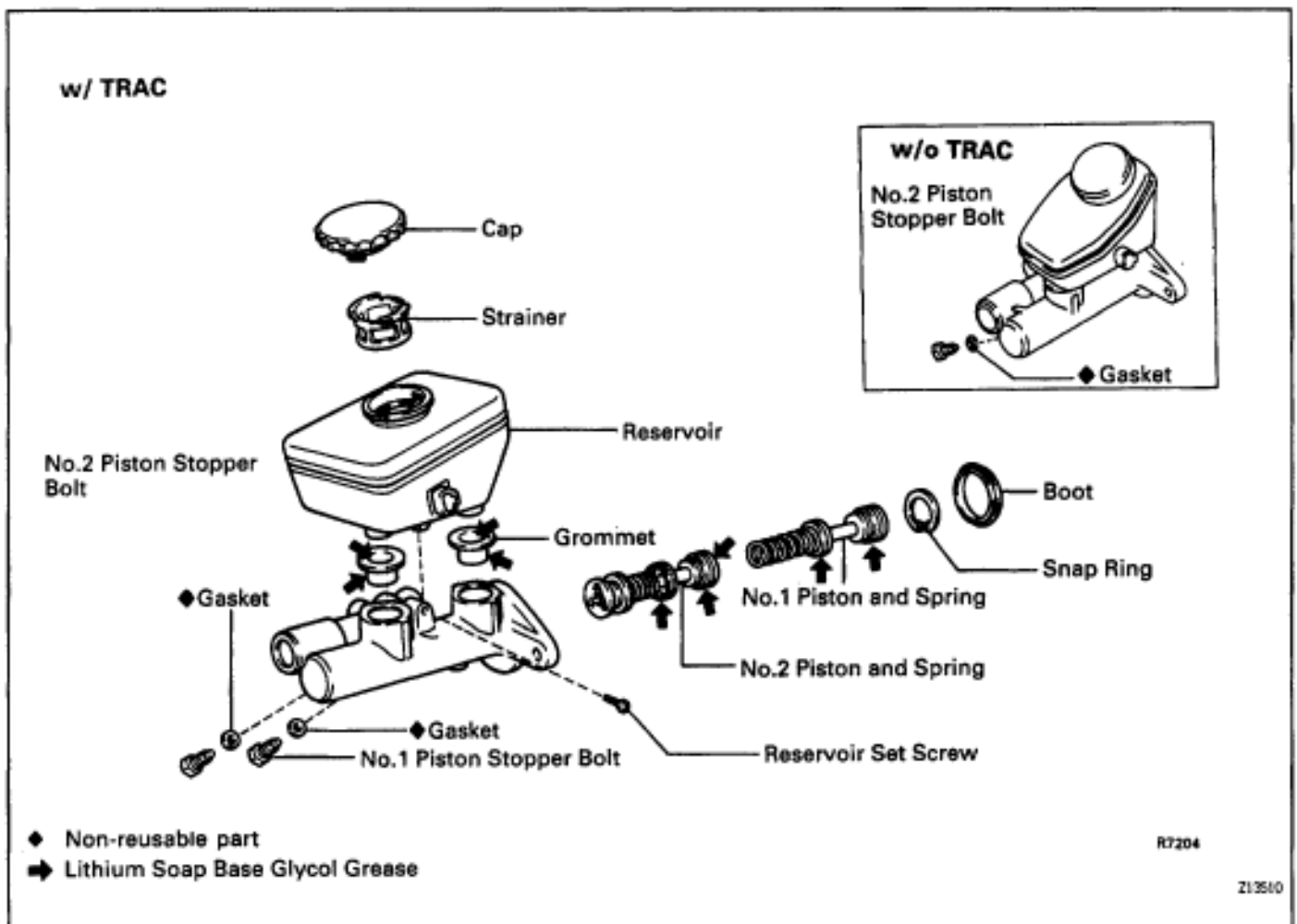

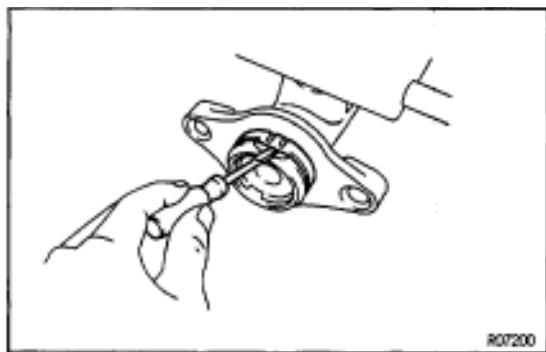

MASTER CYLINDER DISASSEMBLY

Assembly is in the reverse order of disassembly.

ASSEMBLY NOTICE: Apply lithium soap base glycol grease to the rubber parts indicated by the arrows (See page BR-12).

1. REMOVE MASTER CYLINDER BOOT

Using a screwdriver, remove the master cylinder boot.

ASSEMBLY NOTICE: Facing the UP mark on the master cylinder boot upwards, install the cylinder boot to the master cylinder.

2. REMOVE RESERVOIR CAP AND STRAINER

3. REMOVE RESERVOIR

Remove the set screw and pull out the reservoir.

Torque: 1.7 N·m (17.5 kgf·cm, 15.2 in.·lbf)

4. REMOVE 2 GROMMETS

5. PLACE CYLINDER IN VISE

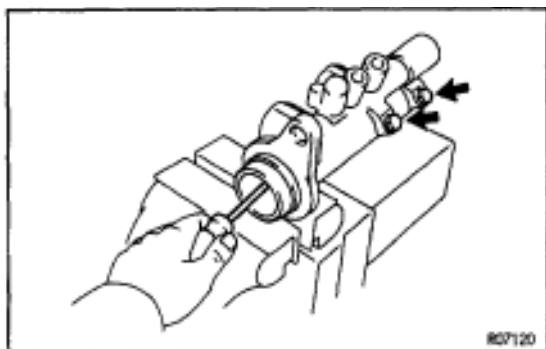

6. w/ TRAC:

REMOVE NO.1 PISTON STOPPER BOLT

Using a screwdriver, push the pistons in all the way and remove the No.1 piston stopper bolt and gasket.

HINT: Tape the screwdriver tip before use.

Torque: 10 N·m (100 kgf·cm, 7 ft·lbf)

7. REMOVE NO.2 PISTON STOPPER BOLT

Using a screwdriver, push the pistons in all the way and remove the No.2 piston stopper bolt and gasket.

Torque: 10 N·m (100 kgf·cm, 7 ft·lbf)

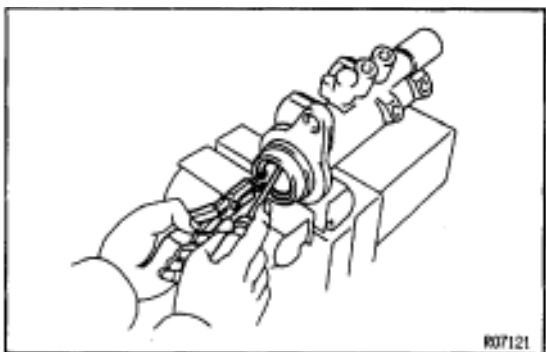

8. REMOVE 2 PISTONS

(a) Push in the piston with a screwdriver and remove the snap ring with snap ring pliers.

HINT: Tape the screwdriver tip before use.

(b) Remove the No.1 piston and spring by hand, pulling straight out, not at an angle.

NOTICE: If pulled out and install at an angle, there is a possibility that the cylinder bore could be damaged.

ASSEMBLY NOTICE: Be careful not to damage the rubber lips on the pistons.

(c) Place a rag and 2 wooden blocks on the work table and lightly tap the cylinder flange against the block edges until the piston drops out of the cylinder.

DISASSEMBLY HINT: Make sure the distance (A) from the rag to the top of the blocks is at least 100 mm (3.94 in.)

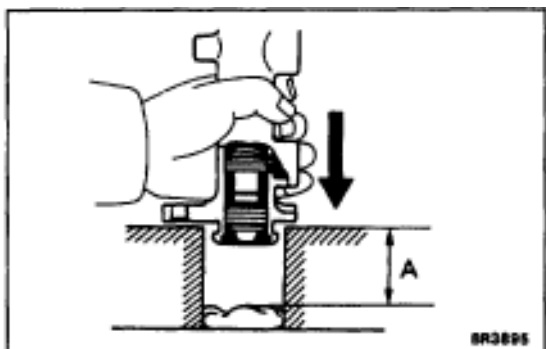

MASTER CYLINDER COMPONENTS INSPECTION

HINT: Clean the disassembled parts with compressed air.

1. **INSPECT CYLINDER BORE FOR RUST OR SCORING**
2. **INSPECT CYLINDER FOR WEAR OR DAMAGE**

If necessary, clean or replace the cylinder.

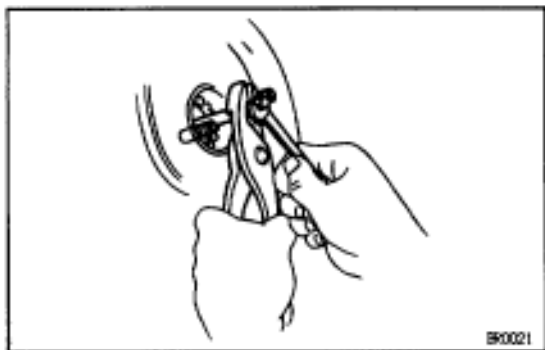

MASTER CYLINDER INSTALLATION

1. **ADJUST LENGTH OF BRAKE BOOSTER PUSH ROD BEFORE INSTALLING MASTER CYLINDER**

(See page [BR-16](#))

2. **INSTALL MASTER CYLINDER**

Install the master cylinder and a new gasket on the brake booster with the 2 nuts.

Torque: 13 N·m (130 kgf·cm, 9 ft·lbf)

3. **CONNECT BRAKE LINES**

Using SST, connect the brake 2 lines to the master cylinder. Torque the union nuts.

SST 09751-36011

Torque: 15 N·m (155 kgf·cm, 11 ft·lbf)

4. **CONNECT LEVEL WARNING SWITCH CONNECTOR**
5. **FILL BRAKE RESERVOIR WITH BRAKE FLUID AND BLEED BRAKE SYSTEM**

(See page [BR-7](#))

6. **w/ TRAC:
BLEED TRAC SYSTEM**

(See page [BR-9](#))

7. **CHECK FOR FLUID LEAKAGE**
 8. **CHECK AND ADJUST BRAKE PEDAL**
- (See page [BR-6](#))

BRAKE BOOSTER

BRAKE BOOSTER REMOVAL

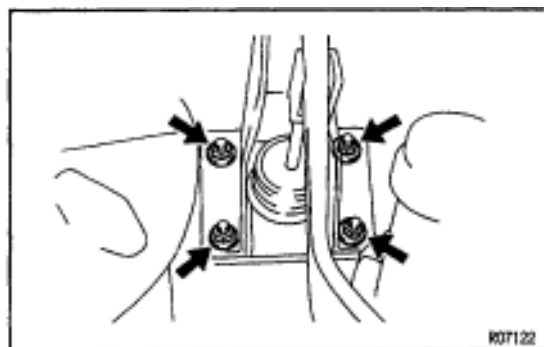
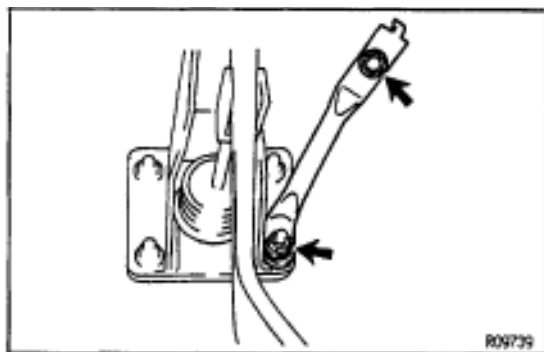
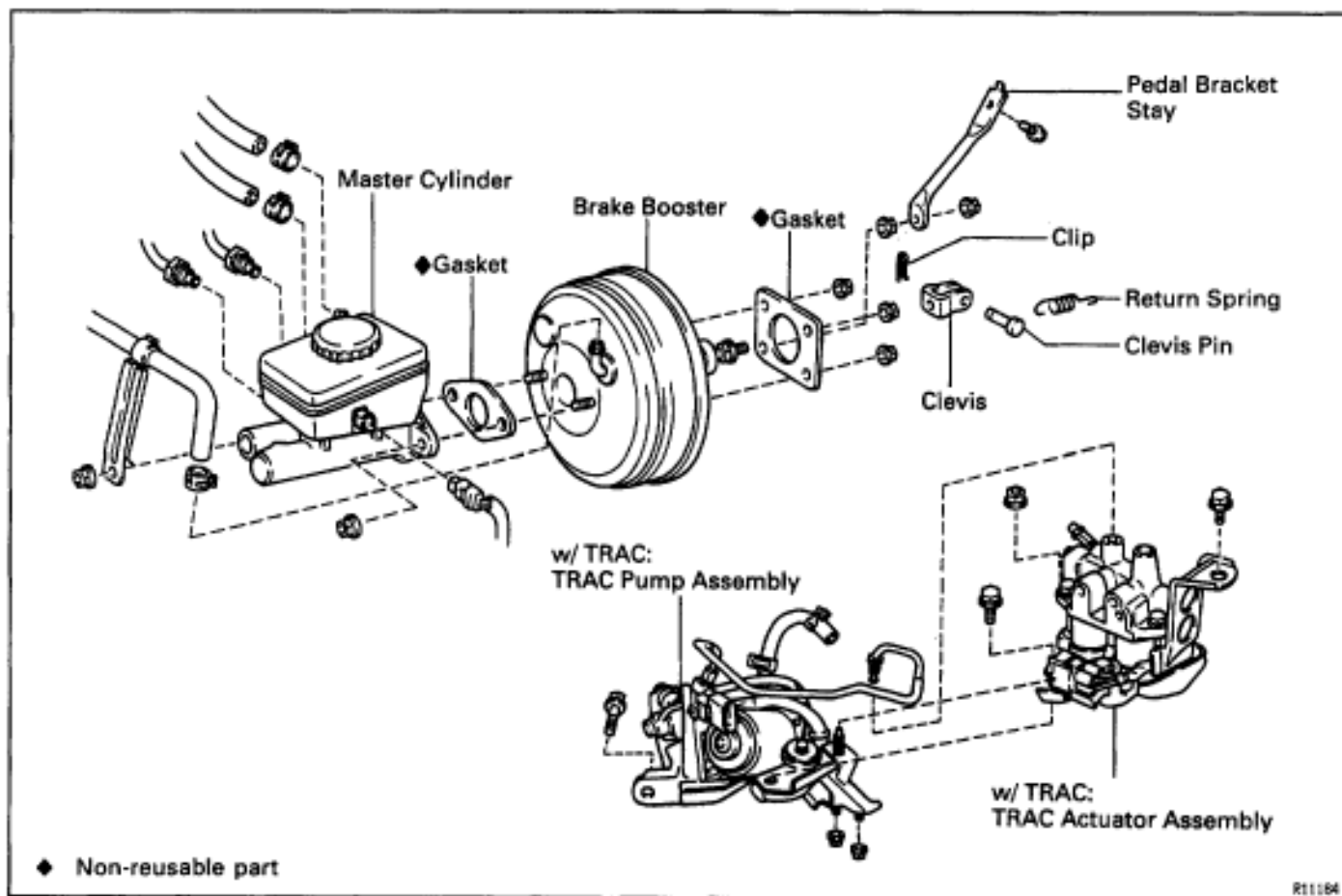

1. REMOVE THESE PARTS:

- Master cylinder (See page [BR-11](#))
- Vacuum hose
- Clip, clevis pin and return spring

w/ TRAC:

- TRAC actuator assembly (See page [BR-121](#))
- TRAC pump assembly (See page [BR-118](#))

2. REMOVE PEDAL BRACKET STAY

- (a) Remove the steering column assembly.
(See page [SR-14](#))

- (b) Remove the bolt and nut.

- (c) Remove the pedal bracket stay.

3. REMOVE BRAKE BOOSTER

- (a) Remove the booster installation nuts.

- (b) Remove the booster and gasket.

BRAKE BOOSTER INSTALLATION

1. INSTALL BRAKE BOOSTER

- (a) Install the booster and a new gasket.
- (b) Install and torque the booster installation nuts.
Torque: 12 N·m (125 kgf·cm, 9 ft·lbf)
- (c) Insert the clevis pin into the clevis and brake pedal, and install the clip to the clevis pin.
- (d) Install the pedal return spring.

2. ADJUST LENGTH OF BOOSTER PUSH ROD

- (a) Install the gasket on the master cylinder.
- (b) Set the SST on the gasket, and lower the pin until its tip slightly touches the piston.
SST 09737-00010
- (c) Turn the SST upside down, and set it on the booster.
SST 09737-00010
- (d) Measure the clearance between the booster push rod and pin head (SST).

Clearance:

0 mm (0 in.)

- (e) Adjust the booster push rod length until the push rod lightly touches the pin head.
HINT: When adjusting the push rod, depress the brake pedal enough so that the push rod sticks out.

3. INSTALL PEDAL BRACKET STAY

- (a) Install the pedal bracket stay.
- (b) Install the bolt and nut.
- (c) Install the steering column assembly. (See page [SR-21](#))

4. INSTALL THESE PARTS:

- Vacuum hose
- Master cylinder (See page [BR-14](#))

w/ TRAC:

- TRAC pump assembly (See page [BR-118](#))
- TRAC actuator assembly (See page [BR-121](#))

5. FILL BRAKE RESERVOIR WITH BRAKE FLUID AND BLEED BRAKE SYSTEM (See page [BR-7](#))

6. w/TRAC:

BLEED TRAC SYSTEM (See page [BR-9](#))

7. CHECK FOR FLUID LEAKAGE

8. CHECK AND ADJUST BRAKE PEDAL (See page [BR -6](#))

9. DO OPERATIONAL CHECK (See page [BR-7](#))

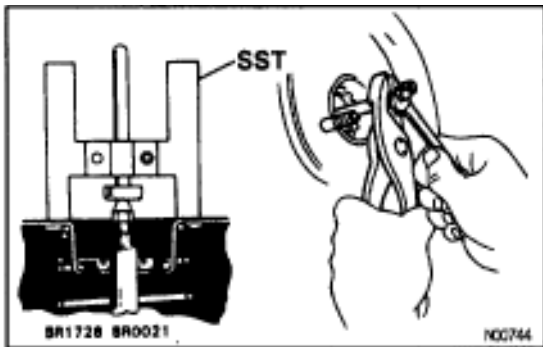
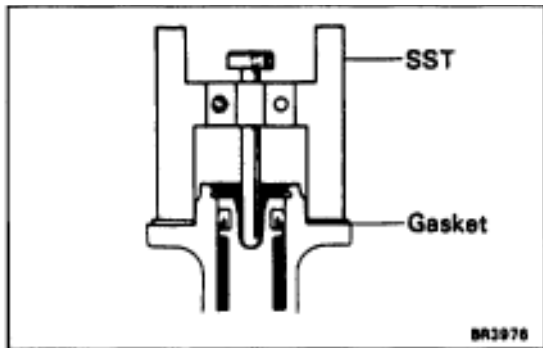

FRONT BRAKE (2JZ-GE) COMPONENTS

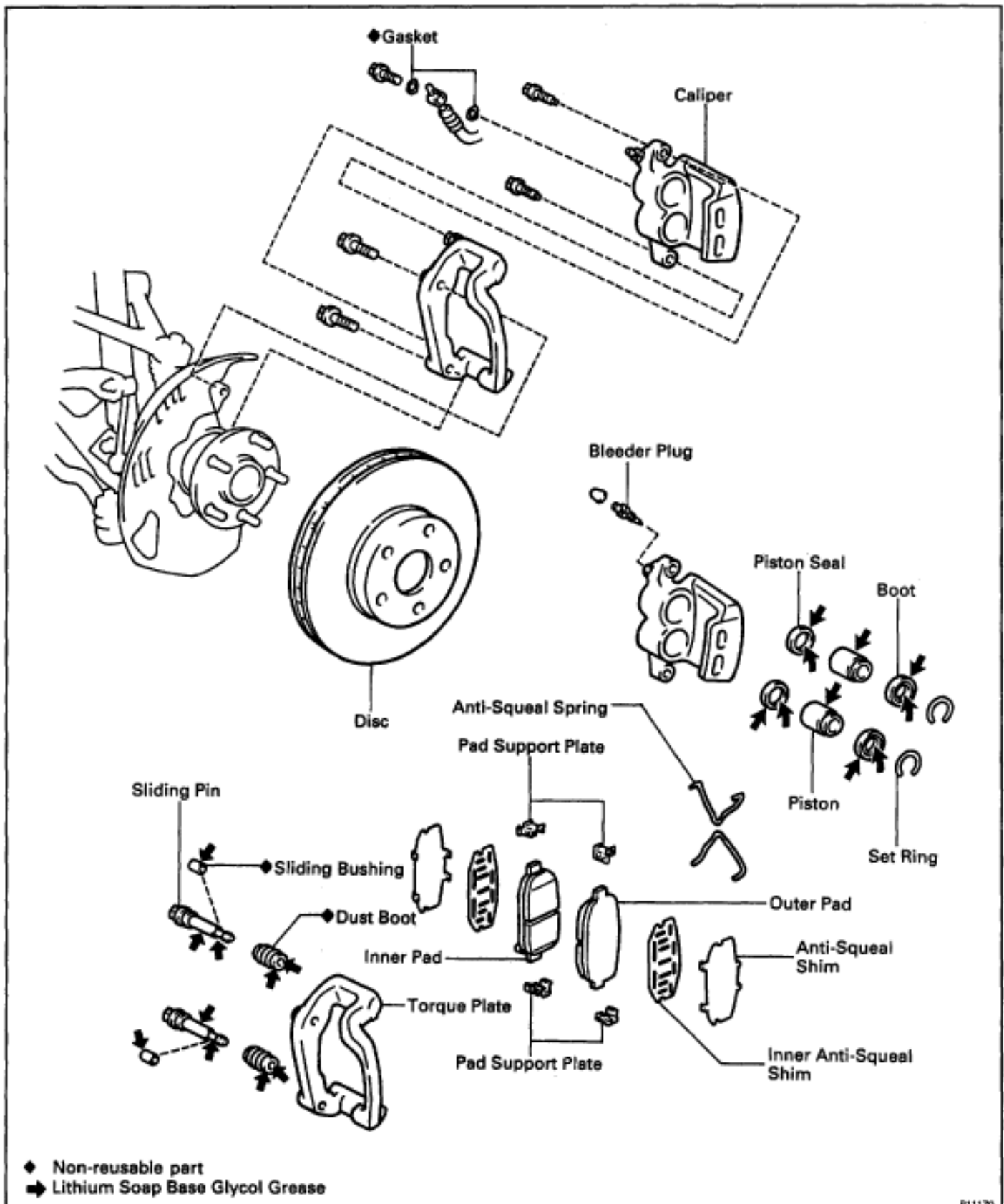

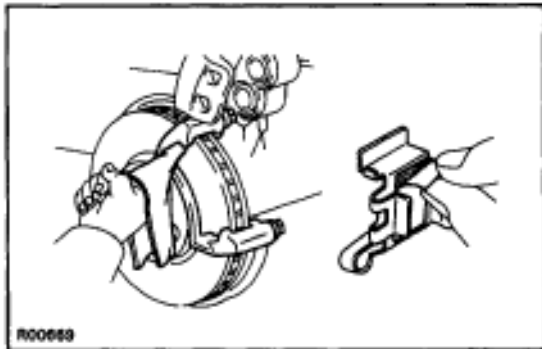
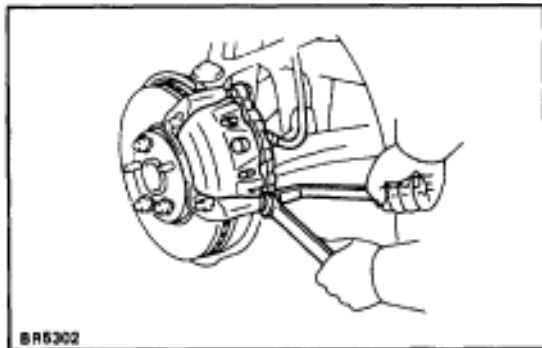
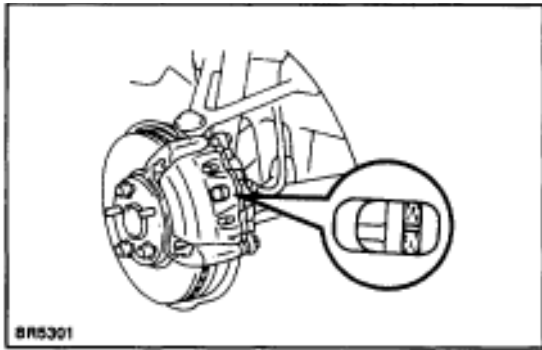

BRAKE PADS REPLACEMENT

1. REMOVE FRONT WHEEL

Remove the wheel and temporarily fasten the disc with the hub nuts.

2. INSPECT PAD LINING THICKNESS

Check the pad thickness through the caliper inspection hole and replace the pads if they are not within the specification.

Minimum thickness:

1.0 mm (0.039 in.)

3. LIFT UP CALIPER

(a) Hold the sliding pin on the bottom and loosen the installation bolt.

(b) Remove the installation bolt.

(c) Lift up the caliper and suspend it securely.

HINT: Do not disconnect the brake hose from the caliper.

4. REMOVE THESE PARTS:

(a) 2 anti-squeal springs

(b) 2 brake pads

(c) 4 anti-squeal shims

(d) 4 pad support plates

NOTICE: The anti-squeal springs can be used again provided that they have sufficient rebound, no deformation, cracks or wear, and have had all rust, dirt and foreign particles cleaned off.

5. CHECK DISC THICKNESS AND RUNOUT

(See page [BR-21](#))

6. INSTALL UNDER SIDE PAD SUPPORT PLATES

7. INSTALL UPPER SIDE PAD SUPPORT PLATES

(a) Using cleaner, wipe off dust, water, oil, etc. from the pad support plate contact area of the torque plate.

(b) Remove the pad support cover sheets from new pad support plate.

(c) Install the new pad support plates.

8. INSTALL NEW PADS

NOTICE: When replacing worn pads, the anti-squeal shims must be replaced together with the pads.

(a) Apply disc brake grease to both sides of the inner anti-squeal shim.

(b) Install the 2 anti-squeal shims on each pad.

(d) Install 2 pads with the pad wear indicator plates facing downward.

NOTICE: There should be no oil or grease adhering to the friction surfaces of the pads or the disc.

(e) Install the 2 anti-squeal springs.

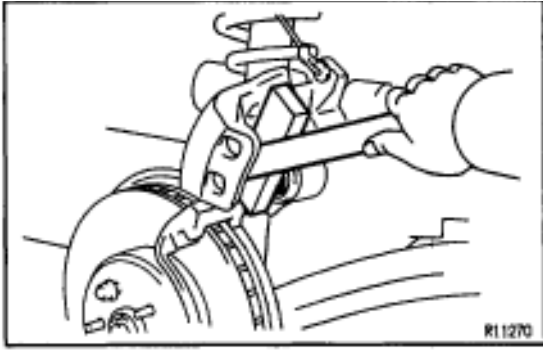

9. INSTALL CALIPER

- (a) Draw out a small amount of brake fluid from the reservoir.
- (b) Press in the piston with water pump pliers or similar implement.

HINT:

- Always change the pads on one wheel at a time as there is a possibility of the opposite piston flying out.
- If the piston is difficult to push in, loosen the bleeder plug and push in the piston while letting some brake fluid escape.

- (c) Install the caliper.
- (d) Hold the sliding pin and torque the installation bolt.
Torque: 34 N·m (350 kgf·cm, 25 ft·lbf)

10. INSTALL FRONT WHEEL

11. CHECK THAT FLUID LEVEL IS AT MAX LINE

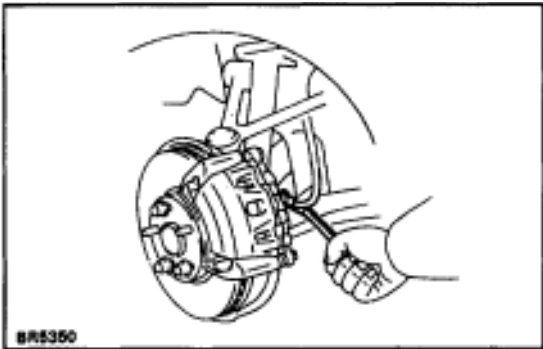

CALIPER REMOVAL

Installation is in the reverse order of removal.

AFTER INSTALLATION, FILL BRAKE RESERVOIR WITH BRAKE FLUID, BLEED BRAKE SYSTEM (See page BR-7) AND CHECK FOR LEAKS

1. DISCONNECT BRAKE HOSE

- (a) Remove the union bolt and 2 gaskets from the brake caliper, then disconnect the brake hose from the brake caliper.
Torque: 29 N·m (300 kgf·cm, 21 ft·lbf)

INSTALLATION HINT: Install the flexible hose lock securely in the lock hole in the caliper.

- (b) Use a container to catch the brake fluid as it drains out.

2. REMOVE CALIPER

- (a) Hold the sliding pin and loosen the 2 installation bolts.
Torque: 34 N·m (350 kgf·cm, 25 ft·lbf)

- (b) Remove the 2 installation bolts.
- (c) Remove the caliper from the torque plate.

3. REMOVE THESE PARTS:

- (a) 2 anti-squeal springs
- (b) 2 brake pads with anti-squeal shims

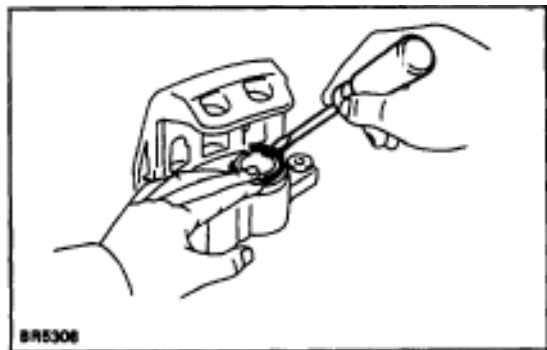

CALIPER DISASSEMBLY

Assembly is in the reverse order of disassembly.

ASSEMBLY NOTICE: Apply lithium soap base glycol grease to the parts indicated by the arrows (See page BR-17).

1. REMOVE CYLINDER BOOT SET RINGS AND BOOTS

Using a screwdriver, remove the cylinder boot set rings and boots from the cylinder.

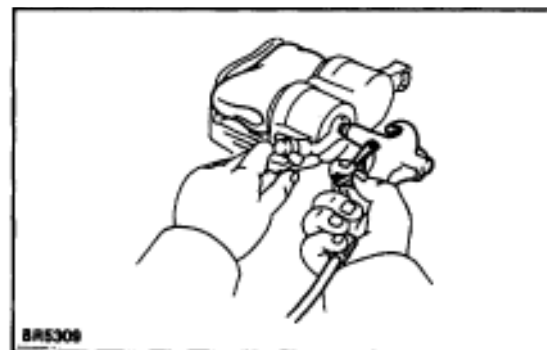

2. REMOVE PISTONS

(a) Place a piece of cloth or similar article between the piston and the caliper.

(b) Use compressed air to remove the pistons from the cylinder.

DISASSEMBLY CAUTION: Do not place your fingers in front of the piston when using compressed air.

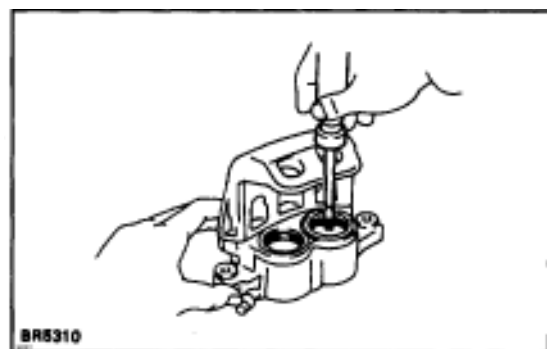

3. REMOVE PISTON SEALS

Using a screwdriver, remove the piston seals from the cylinder.

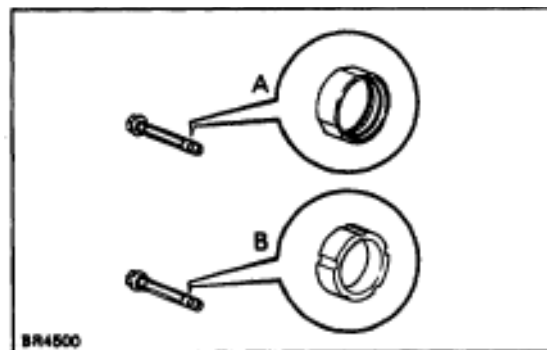

4. REMOVE SLIDING PINS AND DUST BOOTS

(a) Remove the 2 sliding pins from the torque plate.

ASSEMBLY NOTICE: Insert the sliding pin with sliding bushing A into the upper part, and insert the sliding pin with sliding bushing B into the lower part.

(b) Using a screwdriver and hammer, tap out the 2 dust boots.
ASSEMBLY HINT: Use a 19 mm socket and tap in 2 new dust boots into the torque plate.

ASSEMBLY NOTICE: Confirm that the metal plate portion of the dust boot fits snugly in the torque plate.

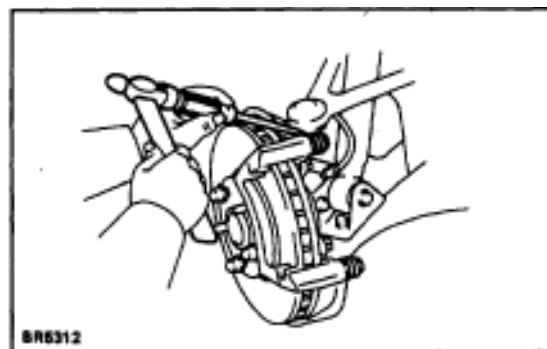

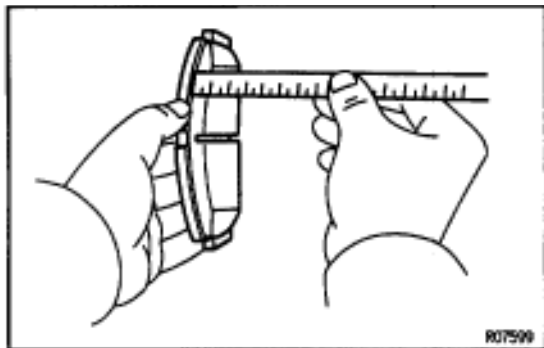

FRONT BRAKE COMPONENTS INSPECTION AND REPAIR

1. MEASURE PAD LINING THICKNESS

Using a ruler, measure the pad lining thickness.

Standard thickness:

11.0 mm (0.433 in.)

Minimum thickness:

1.0 mm (0.039 in.)

Replace the pad if the pad's thickness is at the minimum thickness or less, or if the pad has severe, uneven wear.

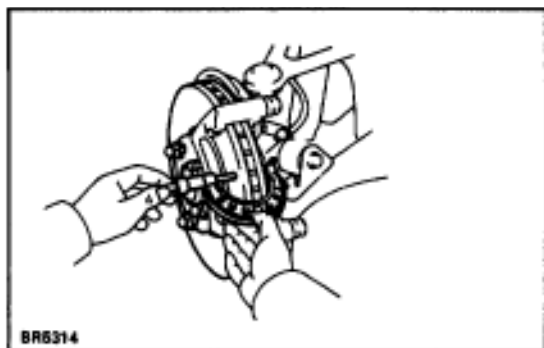

2. MEASURE DISC THICKNESS

Using a micrometer, measure the disc thickness.

Standard thickness:

32 mm (1.260 in.)

Minimum thickness:

30 mm (1.181 in.)

Replace the disc if the thickness of the disc is at the minimum thickness or less. Replace the disc or grind it on a lathe if it is scored or is worn unevenly.

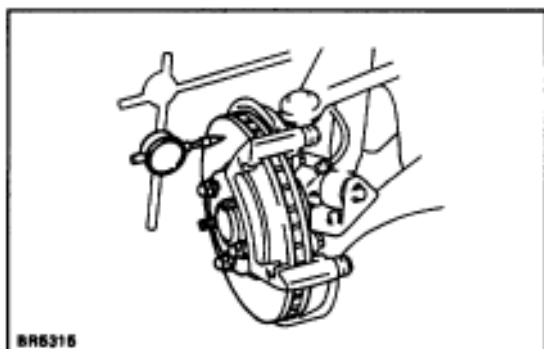

3. MEASURE DISC RUNOUT

Using a dial indicator, measure the disc runout at a position 10 mm (0.39 in.) from the outside edge.

Maximum disc runout:

0.05 mm (0.0020 in.)

If the disc's runout is at the maximum value or greater, check the bearing play in the axial direction and check the axle hub runout (See page SA-16). If the bearing play and axle hub runout are not abnormal, adjust the disc runout.

4. IF NECESSARY, ADJUST DISC RUNOUT

- (a) Remove the 2 bolts and torque plate.
- (b) Remove the hub nuts and the disc. Reinstall the disc 1/5 of a turn round from its original position on the hub. Install and torque the hub nuts.

Torque: 103 N·m (1,050 kgf·cm, 76 ft·lbf)

Remeasure the disc runout. Make a note of the runout and disc's position on the hub.

- (c) Repeat (b) until the disc has been installed on the 3 remaining hub positions.
- (d) If the minimum runout recorded in (b) and (c) is less than 0.05 mm (0.0020 in.), install the disc in that position.
- (e) If the minimum runout recorded in (b) and (c) is greater than 0.05 mm (0.0020 in.), replace the disc and repeat step 3.
- (f) Install the torque plate and torque the 2 bolts.

Torque: 118 N·m (1,200 kgf·cm, 87 ft·lbf)

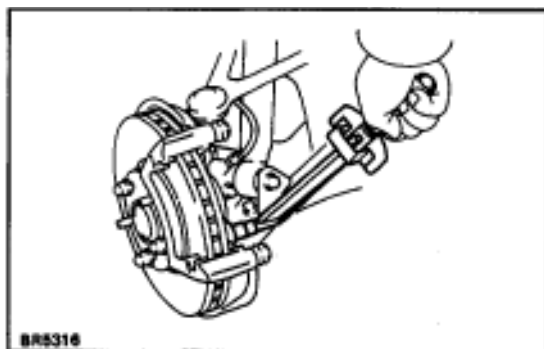

FRONT BRAKE (2JZ-GTE) COMPONENTS

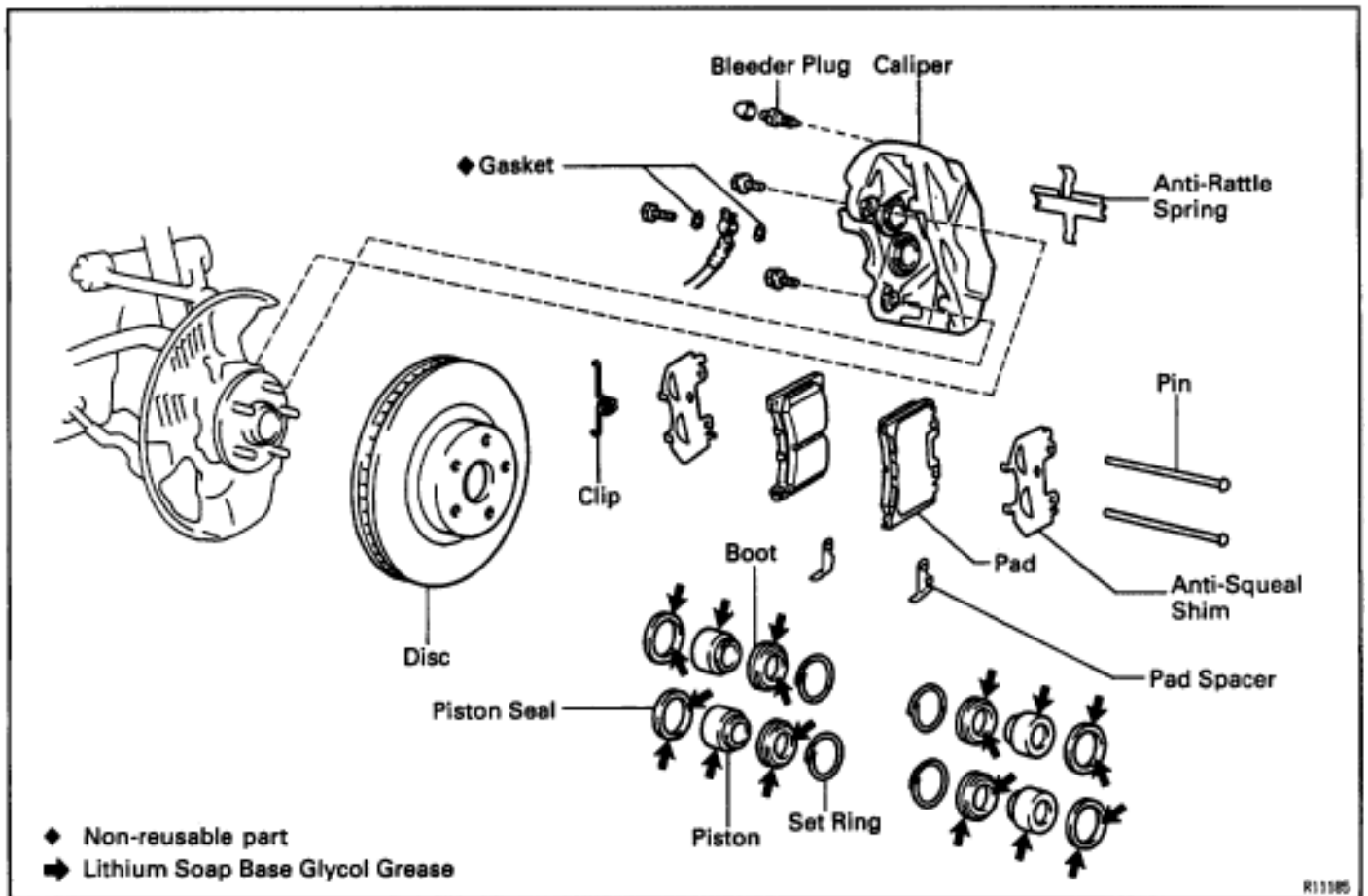

BRAKE PADS REPLACEMENT

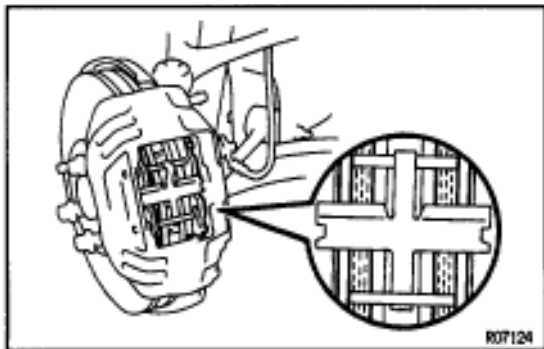

1. REMOVE FRONT WHEEL

Remove the wheel and temporarily fasten the disc with the hub nuts.

2. INSPECT PAD LINING THICKNESS

Check the pad thickness and replace pads if they are not within specification.

Minimum thickness: 1.0 mm (0.039 in.)

3. REMOVE THESE PARTS:

- Clip and 2 pins
- Anti-rattle spring
- 2 pads
- 2 pad spacers
- 2 anti-squeal shims

NOTICE: The anti-rattle spring, clip and pad spacers can be used again provided that they have sufficient rebound, no deformation, cracks or wear, and have had all rust, dirt and foreign particles cleaned off.

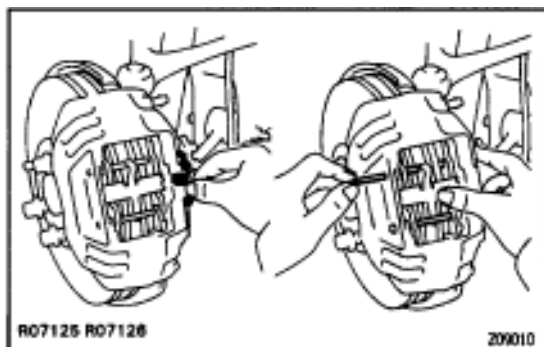

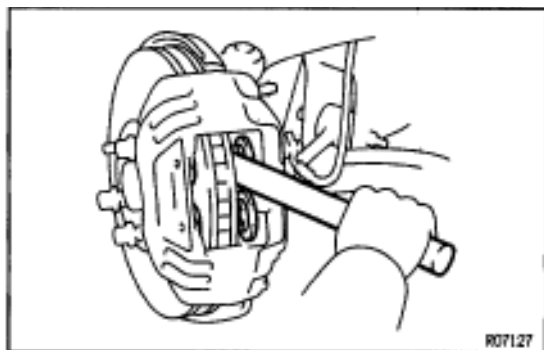

4. CHECK DISC THICKNESS AND RUNOUT

(See page BR-25)

5. INSTALL NEW PADS

NOTICE: When replacing worn pads, the anti-squeal shims must be replaced together with the pads.

- (a) Draw out a small amount of brake fluid from the reservoir.
- (b) Press in the pistons with a hammer handle or equivalent.

HINT:

- Always change the pads on one wheel at a time as there is a possibility of the opposite piston flying out.
- If the piston is difficult to push in, loosen the bleeder plug and push in the piston while letting some brake fluid escape.

- (c) Install the anti-squeal shim on each pad.

HINT:

- Place the pad wear indicator facing downward.
- Apply disc brake grease to inner side of the antisqueal.
- Make sure that the arrow on the shims points upward.

- (d) Install a pad spacer on the lower side of the each pad.

- (e) Install the 2 pads.

NOTICE: Do not allow oil or grease to get on the rubbing face.

6. INSTALL ANTI-RATTLE SPRING AND 2 PINS

7. INSTALL CLIP

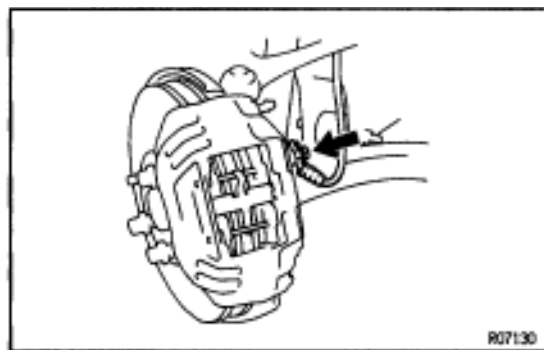
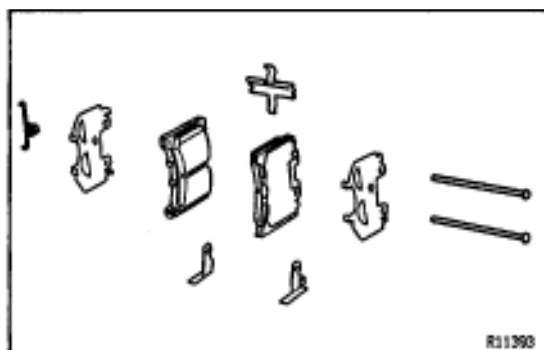

CALIPER REMOVAL

Installation is in the reverse order of removal.

AFTER INSTALLATION, FILL BRAKE RESERVOIR WITH BRAKE FLUID, BLEED BRAKE SYSTEM (See page BR-7) AND CHECK FOR LEAKS

1. REMOVE FRONT WHEEL
2. DISCONNECT BRAKE HOSE

- (a) Remove the union bolt and 2 gaskets from the caliper, then disconnect the brake hose from the caliper.

Torque: 30 N·m (310 kgf·cm, 22 ft·lbf)

INSTALLATION HINT: Install the flexible hose lock securely in the lock hole in the caliper.

- (b) Use a container to catch the brake fluid as it drains out.



3. REMOVE CALIPER

Remove the 2 mounting bolts and caliper.

Torque: 118 N·m (1,200 kgf·cm, 87 ft·lbf)

4. REMOVE THESE PARTS:

- (a) Clip
- (b) 2 pins
- (c) Anti-rattle spring
- (d) 2 pads
- (e) 2 pad spacers
- (f) 2 anti-squeal shims

CALIPER DISASSEMBLY

Assembly is in the reverse order of disassembly.

ASSEMBLY NOTICE: Apply lithium soap base glycol grease to the parts indicated by the arrows (See page BR-22).

1. REMOVE CYLINDER BOOT SET RINGS AND BOOTS

Using a screwdriver, remove the 4 cylinder boot set rings and 4 boots.

2. REMOVE PISTONS FROM CYLINDER

- (a) Prepare a wooden plate to hold the pistons.

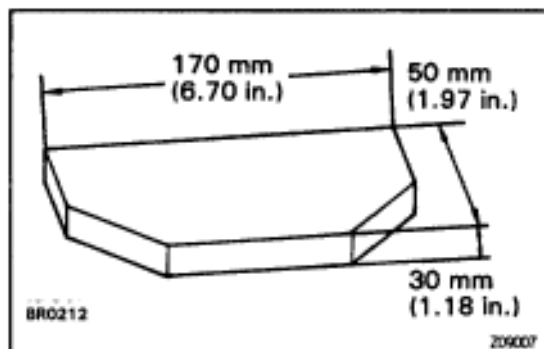
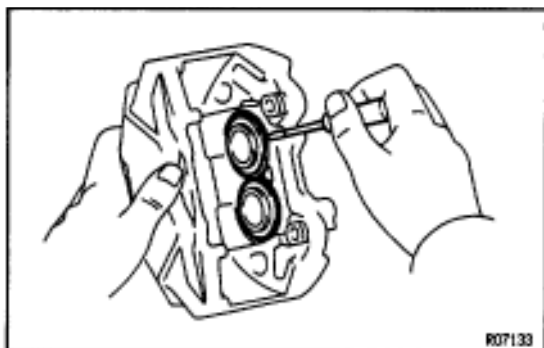

- (b) Place the plate between the pistons and insert a pad on one side.

- (c) Use compressed air to remove the pistons alternately from the cylinder.

DISASSEMBLY CAUTION: Do not place your fingers in front of the pistons when using compressed air.

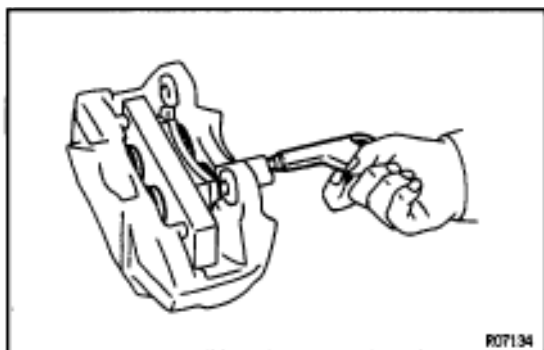

3. REMOVE PISTON SEALS

Using a screwdriver, remove the 4 piston seals from the cylinder.

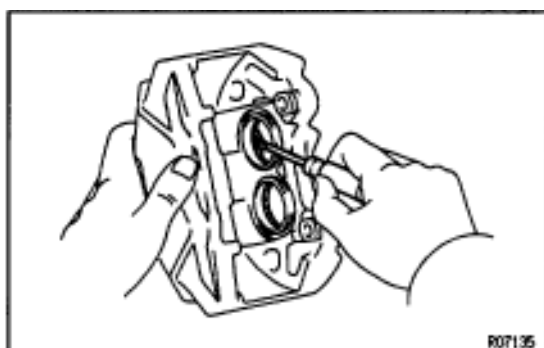

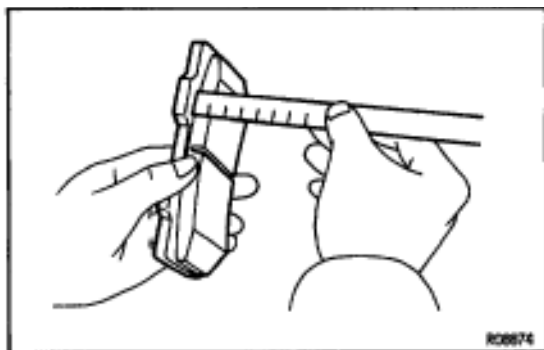

FRONT BRAKE COMPONENTS INSPECTION AND REPAIR

1. MEASURE PAD LINING THICKNESS

Using a ruler, measure the pad lining thickness.

Standard thickness:

12.0 mm (0.472 in.)

Minimum thickness:

1.0 mm (0.039 in.)

Replace the pads if the thickness is less than the minimum (the 1.0 mm slit is no longer visible) or if it shows signs of uneven wear.

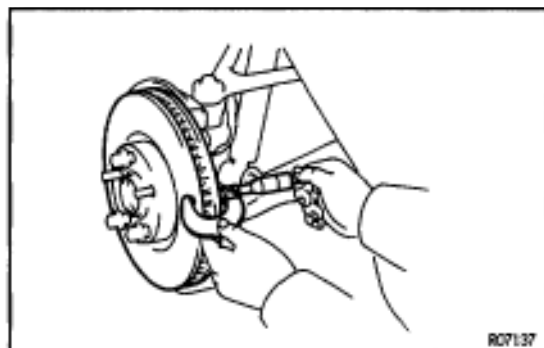

2. MEASURE DISC THICKNESS

Using a micrometer, measure the disc thickness.

Standard thickness:

30.0 mm (1.181 in.)

Minimum thickness:

28.0 mm (1.102 in.)

Replace the disc if the thickness of the disc is at the minimum thickness or less. Replace the disc or grind it on a lathe if it is badly scored or worn unevenly.

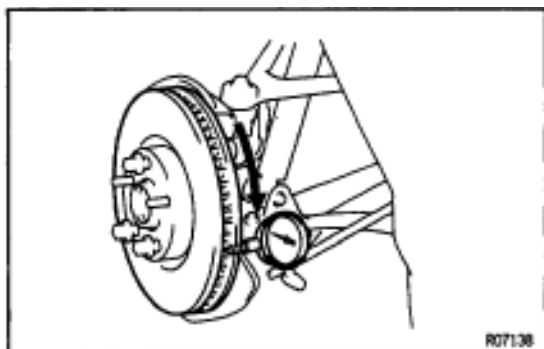

3. MEASURE DISC RUNOUT

Using a dial indicator, measure disc runout 10 mm (0.39 in.) from the outer edge of the disc.

Maximum disc runout:

0.05 mm (0.0020 in.)

If the disc's runout is at the maximum value or greater, check the bearing play in the axial direction and check the axle hub runout (See page SA-16). If the bearing play and axle hub runout are not abnormal, adjust the disc runout.



4. IF NECESSARY, ADJUST DISC RUNOUT

- (a) Remove the hub nuts and the disc. Reinstall the disc 1/5 of a turn round from its original position on the hub. Install and torque the hub nuts.

Torque: 103 N·m (1,050 kgf·cm, 76 ft·lbf)

Remeasure the disc runout. Make a note of the runout and the disc's position on the hub.

- (b) Repeat (a) until the disc has been installed on the 3 remaining hub positions.

- (c) If the minimum runout recorded in (a) and (b) is less than 0.05 mm (0.0020 in.), install the disc in that position.

- (d) If the minimum runout recorded in (a) and (b) is greater than 0.05 mm (0.0020 in.), replace the disc and repeat step 3.

HINT: Install a disc marked with "R" on the right wheel, and a disc marked with "L" on the left wheel.

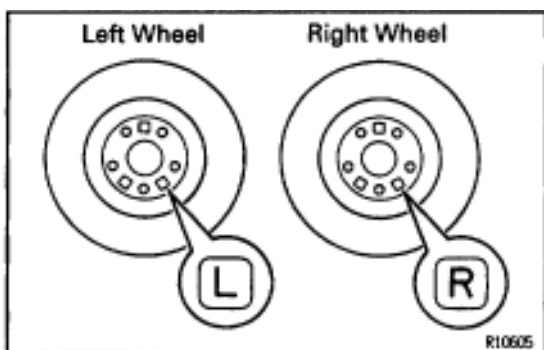

REAR BRAKE (2JZ-GE) COMPONENTS

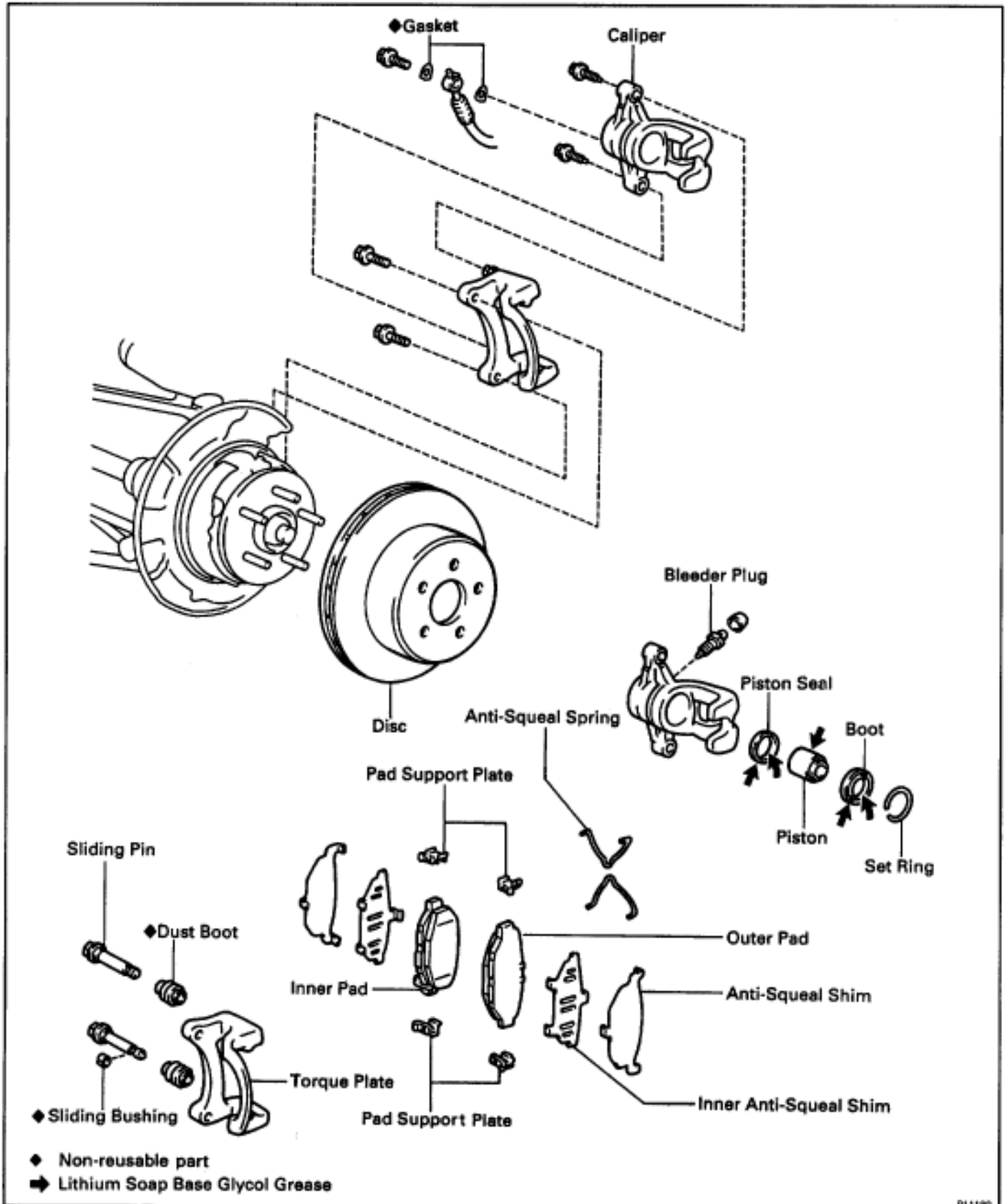

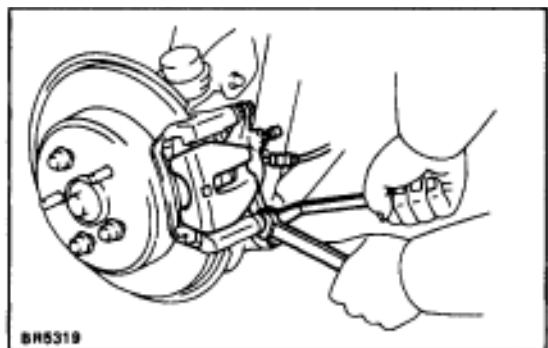
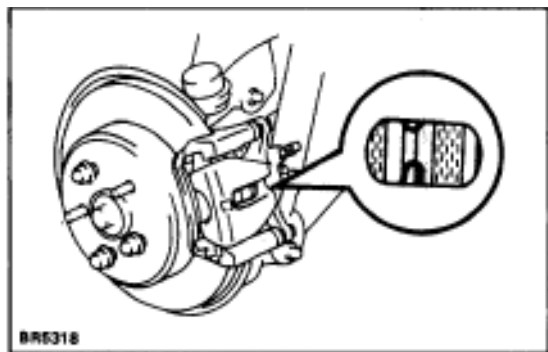

BRAKE PADS REPLACEMENT

1. REMOVE REAR WHEEL

Remove the wheel and temporarily fasten the disc with the hub nuts.

2. INSPECT PAD LINING THICKNESS

Check the pad thickness through the caliper inspection hole and replace pads if the thickness is not within the specification.

Minimum thickness:

1.0 mm (0.039 in.)

3. LIFT UP CALIPER

- (a) Hold the sliding pin on the bottom and loosen the installation bolt.
 - (b) Remove the installation bolt.
 - (c) Lift up the caliper and suspend it securely.
- HINT:** Do not disconnect the brake hose from the caliper.

4. REMOVE THESE PARTS:

- (a) 2 anti-squeal springs
- (b) 2 brake pads
- (c) 4 anti-squeal shims
- (d) 4 pad support plates

NOTICE: The anti-squeal springs and support plates can be used again provided that they have sufficient rebound, no deformation, cracks or wear, and have had all rust, dirt and foreign particles cleaned off.

5. CHECK DISC THICKNESS AND RUNOUT

(See page [BR-30](#))

6. INSTALL 4 PAD SUPPORT PLATES

7. INSTALL NEW PADS

NOTICE: When replacing worn pads, the anti-squeal shims must be replaced together with the pads.

- (a) Apply disc brake grease to both sides of the inner anti-squeal shim.
- (b) Install the 2 anti-squeal shims on each pad.
- (c) Install 2 pads with the pad wear indicator plates facing downward.

NOTICE: There should be no oil or grease adhering to the friction surfaces of the pads or the disc.

- (d) Install the 2 anti-squeal springs.

8. INSTALL CALIPER

- (a) Draw out a small amount of brake fluid from the reservoir.

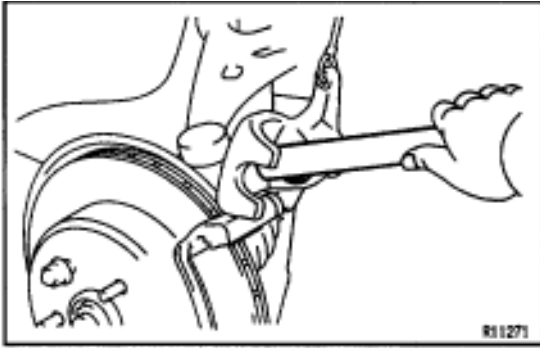

- (b) Press in the piston with water pump pliers or similar implement.

HINT:

- Always change the pads on one wheel at a time as there is a possibility of the opposite piston flying out.
- If the piston is difficult to push in, loosen the bleeder plug and push in the piston while letting some brake fluid escape.

- (c) Install the brake caliper.

- (d) Hold the sliding pin and torque the installation bolt.

Torque: 34 N·m (350 kgf·cm, 25 ft·lbf)

9. INSTALL REAR WHEEL

10. CHECK THAT FLUID LEVEL IS AT MAX LINE

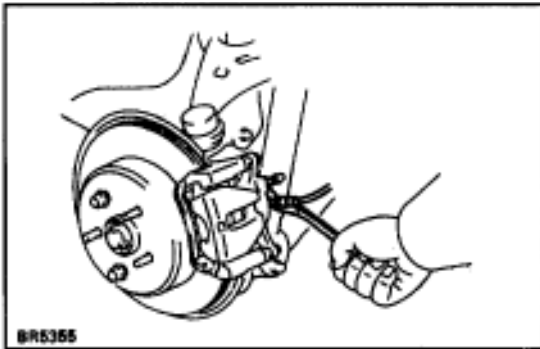

CALIPER REMOVAL

Installation is in the reverse order of removal.

AFTER INSTALLATION, FILL BRAKE RESERVOIR WITH BRAKE FLUID, BLEED BRAKE SYSTEM (See page BR-7).

1. DISCONNECT BRAKE HOSE

- (a) Remove the union bolt and 2 gaskets from the brake caliper, then disconnect the brake hose from the brake caliper.

Torque: 30 N·m (310 kgf·cm, 22 ft·lbf)

INSTALLATION HINT: Install the flexible hose lock securely in the lock hole in the caliper.

- (b) Use a container to catch the brake fluid as it drains out.

2. REMOVE CALIPER

- (a) Hold the sliding pin and loosen the 2 installation bolts.

Torque: 34 N·m (350 kgf·cm, 25 ft·lbf)

- (b) Remove the 2 installation bolts.

- (c) Remove the caliper from the torque plate.

3. REMOVE THESE PARTS:

- (a) 2 anti-squeal springs
 (b) 2 brake pads with anti-squeal shims

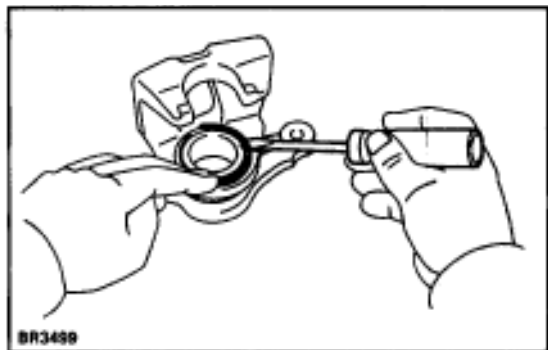

CALIPER DISASSEMBLY

Assembly is in the reverse order of disassembly.

ASSEMBLY NOTICE: Apply lithium soap base glycol grease to the parts indicated by the arrows (See page BR-26).

1. REMOVE CYLINDER BOOT SET RING AND BOOT

Using a screwdriver, remove the cylinder boot set ring and boot from the cylinder.

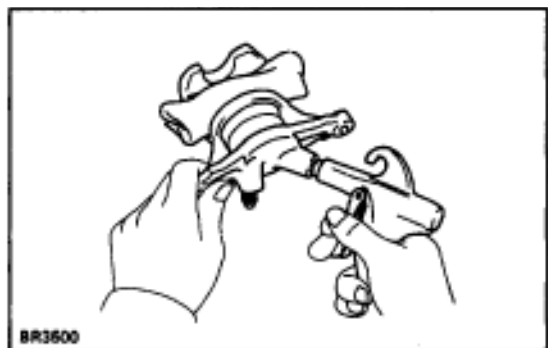

2. REMOVE PISTON

(a) Place a piece of cloth or similar article between the piston and the caliper.

(b) Use compressed air to remove the piston from the cylinder.

DISASSEMBLY CAUTION: Do not place your fingers in front of the piston when using compressed air.

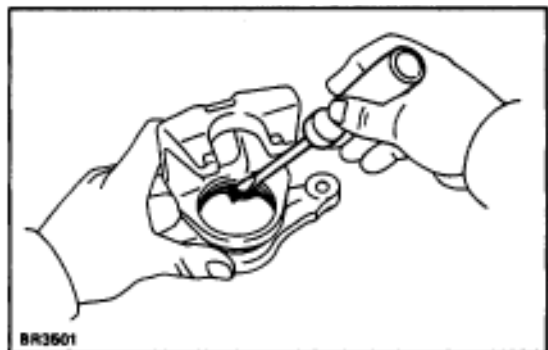

3. REMOVE PISTON SEAL

Using a screwdriver, remove the piston seal from the cylinder.

4. REMOVE SLIDING PINS AND DUST BOOTS

(a) Remove the 2 sliding pins from the torque plate.

ASSEMBLY NOTICE: Insert the sliding pin with the sliding bushing into the bottom side.

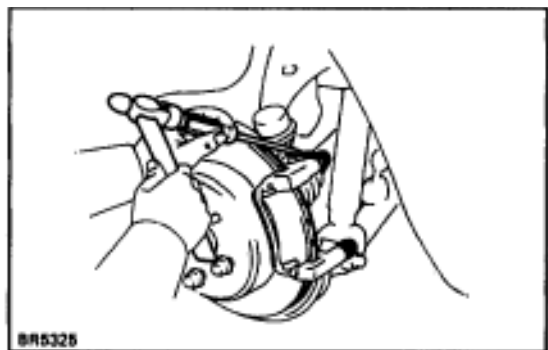

(b) Using a screwdriver and hammer, tap out the 2 dust boots.
ASSEMBLY HINT: Use a 19 mm socket and tap in 2 new dust boots into the torque plate.

ASSEMBLY NOTICE: Confirm that the metal plate portion of the dust boot fits snugly in the torque plate.

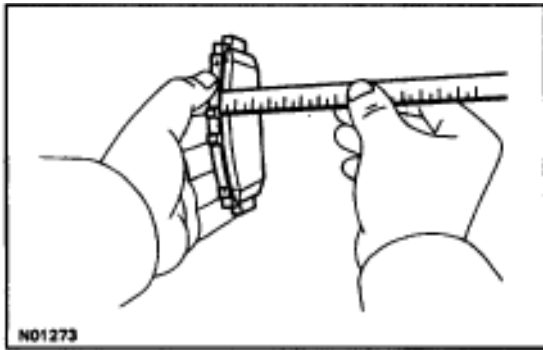

N01273

REAR BRAKE COMPONENTS INSPECTION AND REPAIR

1. MEASURE PAD LINING THICKNESS

Using a ruler, measure the pad lining thickness.

Standard thickness:

10.0 mm (0.394 in.)

Minimum thickness:

1.0 mm (0.039 in.)

Replace the pad if the pad's thickness is at the minimum thickness or less, or if the pad has severe, uneven wear.

2. MEASURE DISC THICKNESS

Using a micrometer, measure the disc thickness.

Standard thickness:

16.0 mm (0.630 in.)

Minimum thickness:

15.0 mm (0.591 in.)

Replace the disc if the thickness of the disc is at the minimum thickness or less. Replace the disc or grind it on a lathe if it is badly scored or worn unevenly.

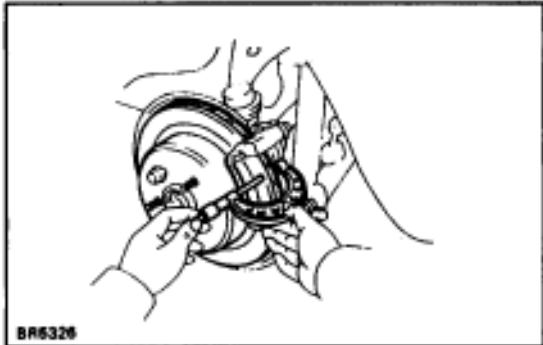

BR6326

3. MEASURE DISC RUNOUT

Using a dial indicator, measure disc runout 10 mm (0.39 in.) from the outer edge of the disc.

Maximum disc runout:

0.05 mm (0.0020 in.)

If the disc's runout is at the maximum value or greater, check the bearing play in the axial direction and check the axle hub runout (See page SA-38). If the bearing play and axle hub runout are not abnormal, adjust the disc runout.

4. IF NECESSARY, ADJUST DISC RUNOUT

- (a) Remove the 2 bolt and torque plate.
- (b) Remove the hub nuts and the disc. Reinstall the disc 1/5 of a turn round from its original position on the hub. Install and torque the hub nuts.

Torque: 103 N·m (1,050 kgf·cm, 76 ft·lbf)

Remeasure the disc runout. Make a note of the runout and the disc's position on the hub.

- (c) Repeat (b) until the disc has been installed on the 3 remaining hub positions.
- (d) If the minimum runout recorded in (b) and (c) is less than 0.05 mm (0.0020 in.), install the disc in that position.
- (e) If the minimum runout recorded in (b) and (c) is greater than 0.05 mm (0.0020 in.), replace the disc and repeat step 3.
- (f) Install the torque plate and tighten the 2 bolts.

Torque: 104 N·m (1,065 kgf·cm, 77 ft·lbf)

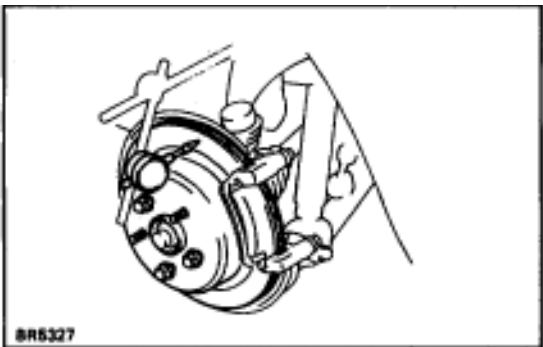

BR6327

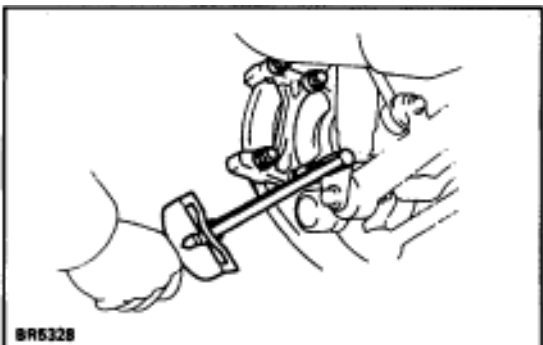

BR6328

REAR BRAKE (2JZ-GTE) COMPONENTS

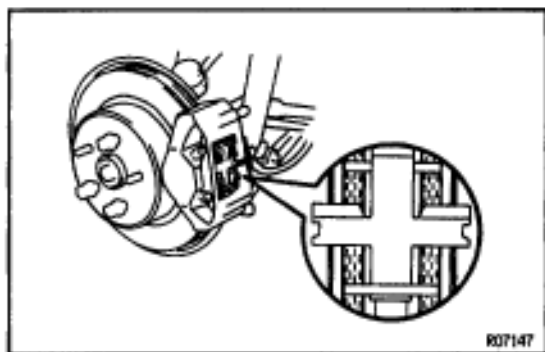
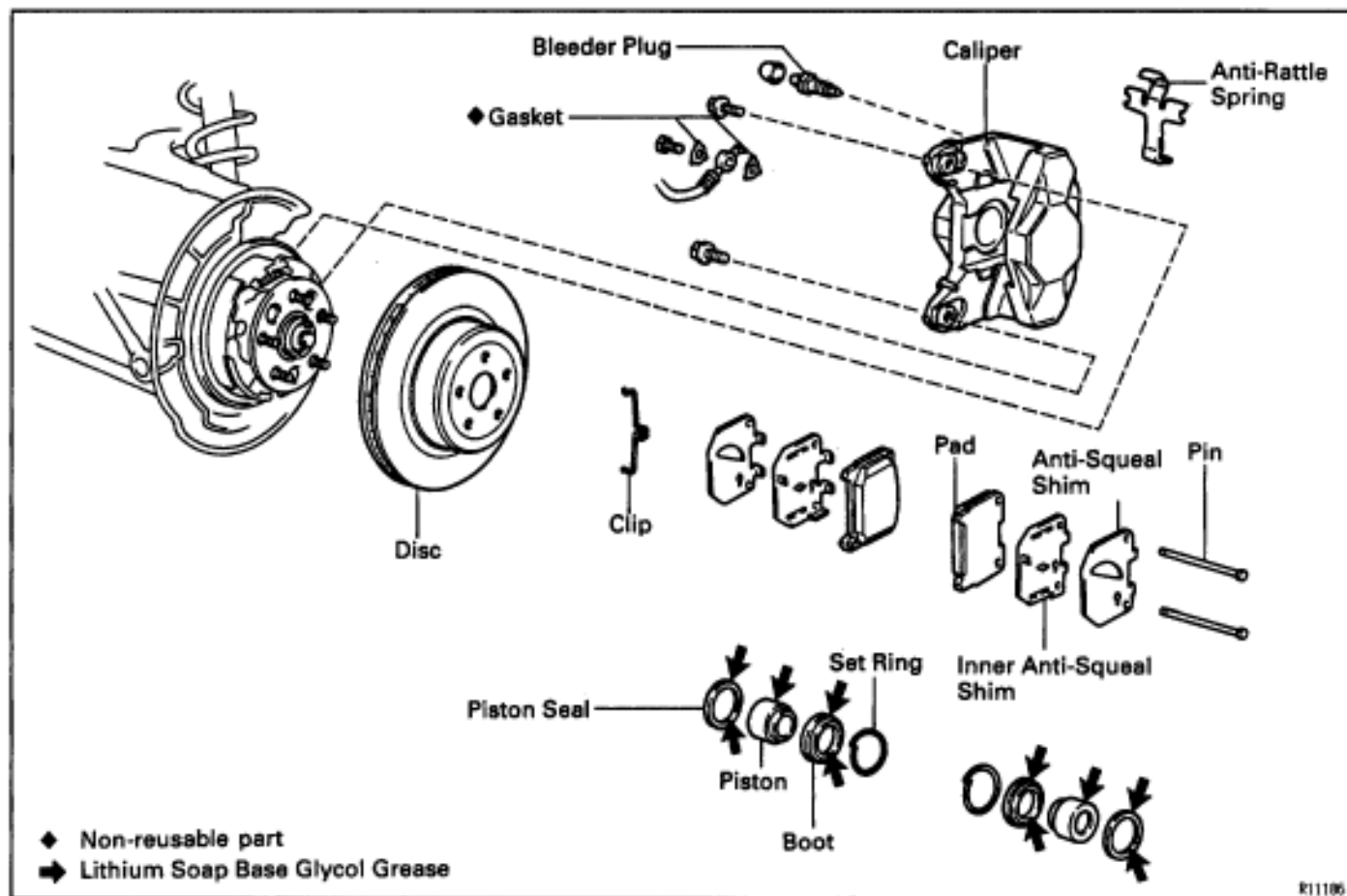

BRAKE PADS REPLACEMENT

1. REMOVE REAR WHEEL

Remove the wheel and temporarily fasten the disc with the hub nuts.

2. INSPECT PAD LINING THICKNESS

Check the pad thickness and replace pads if not within specification.

Minimum thickness: 1.0 mm (0.039 in.)

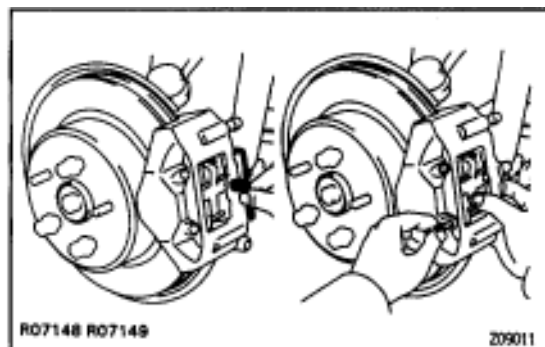

3. REMOVE THESE PARTS:

- Clip and 2 pins
- Anti-rattle spring
- 2 pads
- 4 anti-squeal shims

NOTICE: The anti-rattle springs and clip can be used again provided that they have sufficient rebound, no deformation, cracks or wear, and have had all rust, dirt and foreign particles cleaned off.

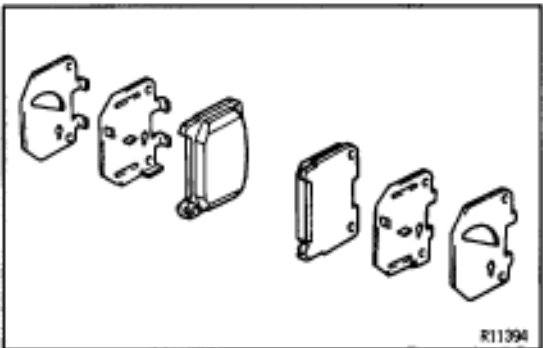
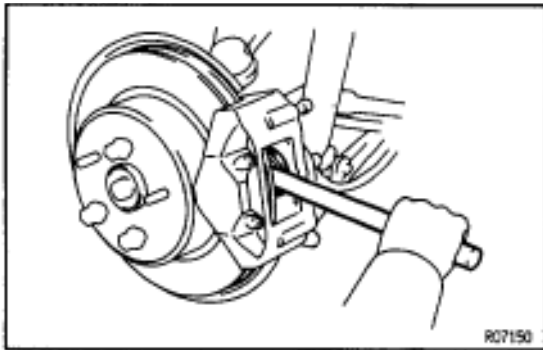

4. CHECK DISC THICKNESS AND RUNOUT

(See page [BR-34](#))

5. INSTALL NEW PADS

NOTICE: When replacing worn pads, the anti-squeal shims must be replaced together with the pads.

- (a) Draw out a small amount of brake fluid from the reservoir.
- (b) Press in the pistons with a hammer handle or equivalent.

HINT:

- Always change the pads on one wheel at a time as there is a possibility of the opposite piston flying out.
- If the piston is difficult to push in, loosen the bleeder plug and push in the piston while letting some brake fluid escape.

- (c) Install the 2 anti-squeal shims on each pad.

HINT:

- Apply disc brake grease to both sides of the inner anti-squeal shim.
- Make sure that the arrow on the shims points upward.

- (d) Install the 2 pads with pad wear indicator plates facing downward.

NOTICE: Do not allow oil or grease to get on the rubbing face.

6. INSTALL ANTI-RATTLE SPRING AND 2 PINS

7. INSTALL CLIP

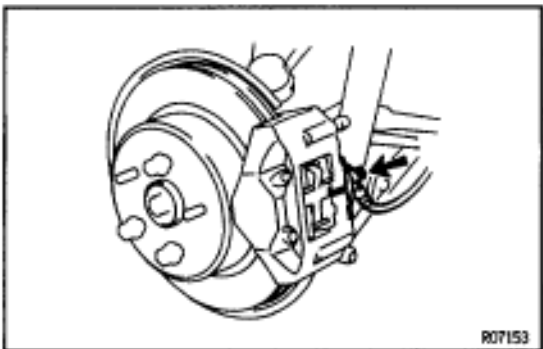

CALIPER REMOVAL

Installation is in the reverse order of removal.

AFTER INSTALLATION, FILL BRAKE RESERVOIR WITH BRAKE FLUID, BLEED BRAKE SYSTEM (See page [BR-7](#)) AND CHECK FOR LEAKS

1. REMOVE REAR WHEEL
2. DISCONNECT BRAKE HOSE

- (a) Remove the union bolt and 2 gaskets from the caliper, then disconnect the brake hose from the caliper.

Torque: 30 N·m (310 kgf·cm, 22 ft·lbf)

INSTALLATION HINT: Install the flexible hose lock securely in the lock hole in the caliper.

- (b) Use a container to catch the brake fluid.

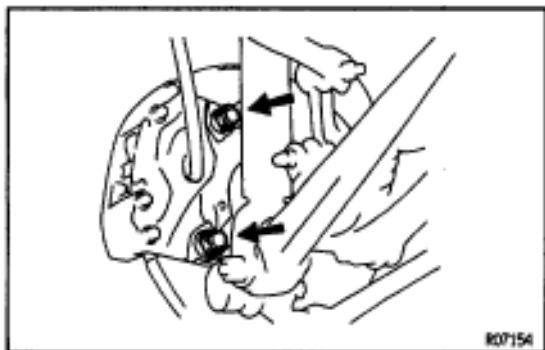

3. REMOVE CALIPER

Remove the 2 mounting bolts and caliper.

Torque: 104 N·m (1,065 kgf·cm, 77 ft·lbf)

4. REMOVE THESE PARTS:

- (a) Clip
- (b) 2 pins
- (c) Anti-rattle spring
- (d) 2 pads
- (e) 4 anti-squeal shims

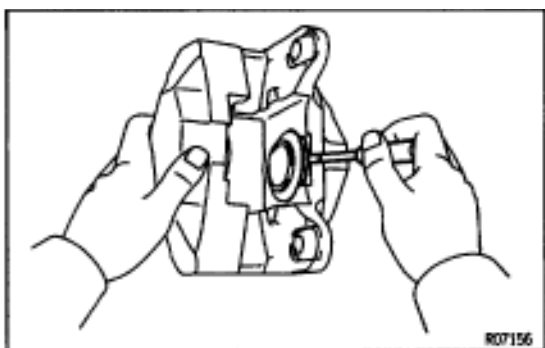

CALIPER DISASSEMBLY

Assembly is in the reverse order of disassembly.

ASSEMBLY NOTICE: Apply lithium soap base glycol grease to the parts indicated by the arrows (See page BR-31)

1. REMOVE CYLINDER BOOT SET RINGS AND BOOTS

Using a screwdriver, remove the 2 cylinder boot set rings and 2 boots.

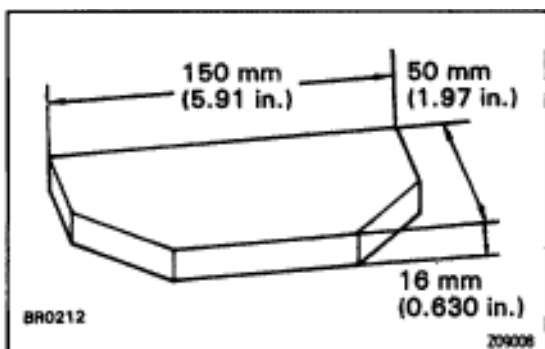

2. REMOVE PISTONS FROM CYLINDER

- (a) Prepare a wooden plate to hold the pistons.

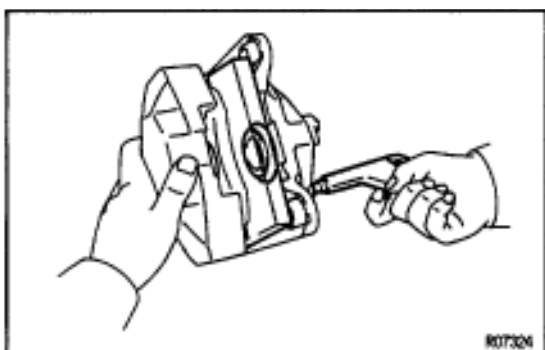

- (b) Place the plate between the pistons and insert a pad on one side.
- (c) Use compressed air to remove the pistons alternately from the caliper.

DISASSEMBLY CAUTION: Do not place your fingers in front of the pistons when using compressed air.

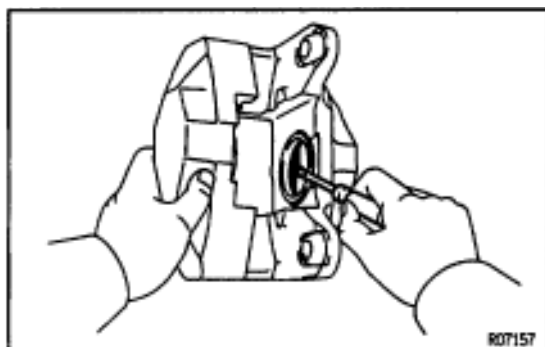

3. REMOVE PISTON SEALS

Using a screwdriver, remove the 2 seals from the cylinder.

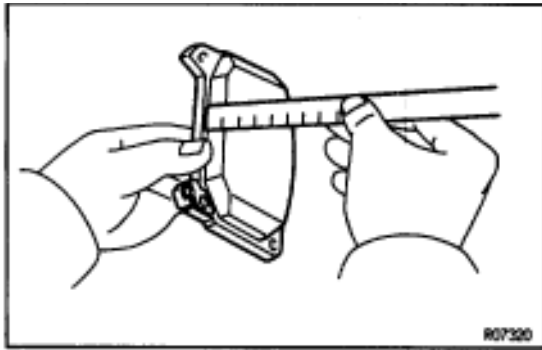

REAR BRAKE COMPONENTS INSPECTION AND REPAIR

1. MEASURE PAD LINING THICKNESS

Using a ruler, measure the lining thickness.

Standard thickness:

11.0 mm (0.433 in.)

Minimum thickness:

1.0 mm (0.039 in.)

Replace the pads if the thickness is less than the minimum (the 1.0 mm slit is no longer visible) or if it shows signs of uneven wear.

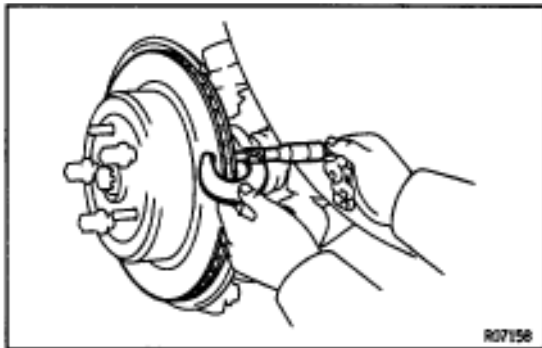

2. MEASURE DISC THICKNESS

Using a micrometer, measure the disc thickness.

Standard thickness:

16.0 mm (0.630 in.)

Minimum thickness:

15.0 mm (0.591 in.)

Replace the disc if the thickness of the disc is at the minimum thickness or less. Replace the disc or grind it on a lathe if it is badly scored or worn unevenly.

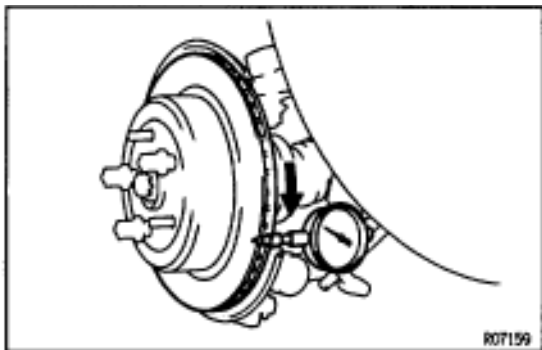

3. MEASURE DISC RUNOUT

Using a dial indicator, measure disc runout 10 mm (0.39 in.) from the outer edge of the disc.

Maximum disc runout:

0.05 mm (0.0020 in.)

If the disc's runout is at the maximum value or greater, check the bearing play in the axial direction and check the axle hub runout (See page SA-38). If the bearing play and axle hub runout are not abnormal, adjust the disc runout.

4. IF NECESSARY, ADJUST DISC RUNOUT

- (a) Remove the hub nuts and the disc. Reinstall the disc 1/5 of a turn round from its original position on the hub. Install and torque the hub nuts.

Torque: 103 N·m (1,050 kgf·cm, 76 ft·lbf)

Remeasure the disc runout. Make a note of the runout and the disc's position on the hub.

- (b) Repeat (a) until the disc has been installed on the 3 remaining hub positions.
- (c) If the minimum runout recorded in (a) and (b) is less than 0.05 mm (0.0020 in.), install the disc in that position.
- (d) If the minimum runout recorded in (a) and (b) is greater than 0.05 mm (0.0020 in.), replace the disc and repeat step 3.

REAR BRAKE (Parking Brake) COMPONENTS

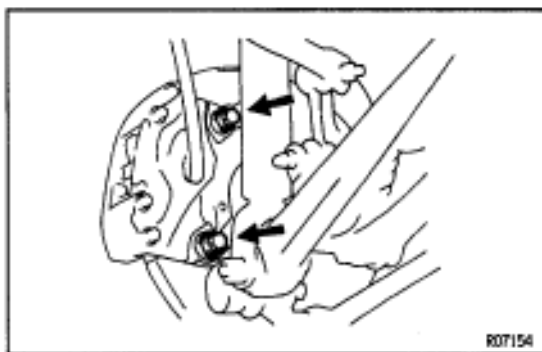
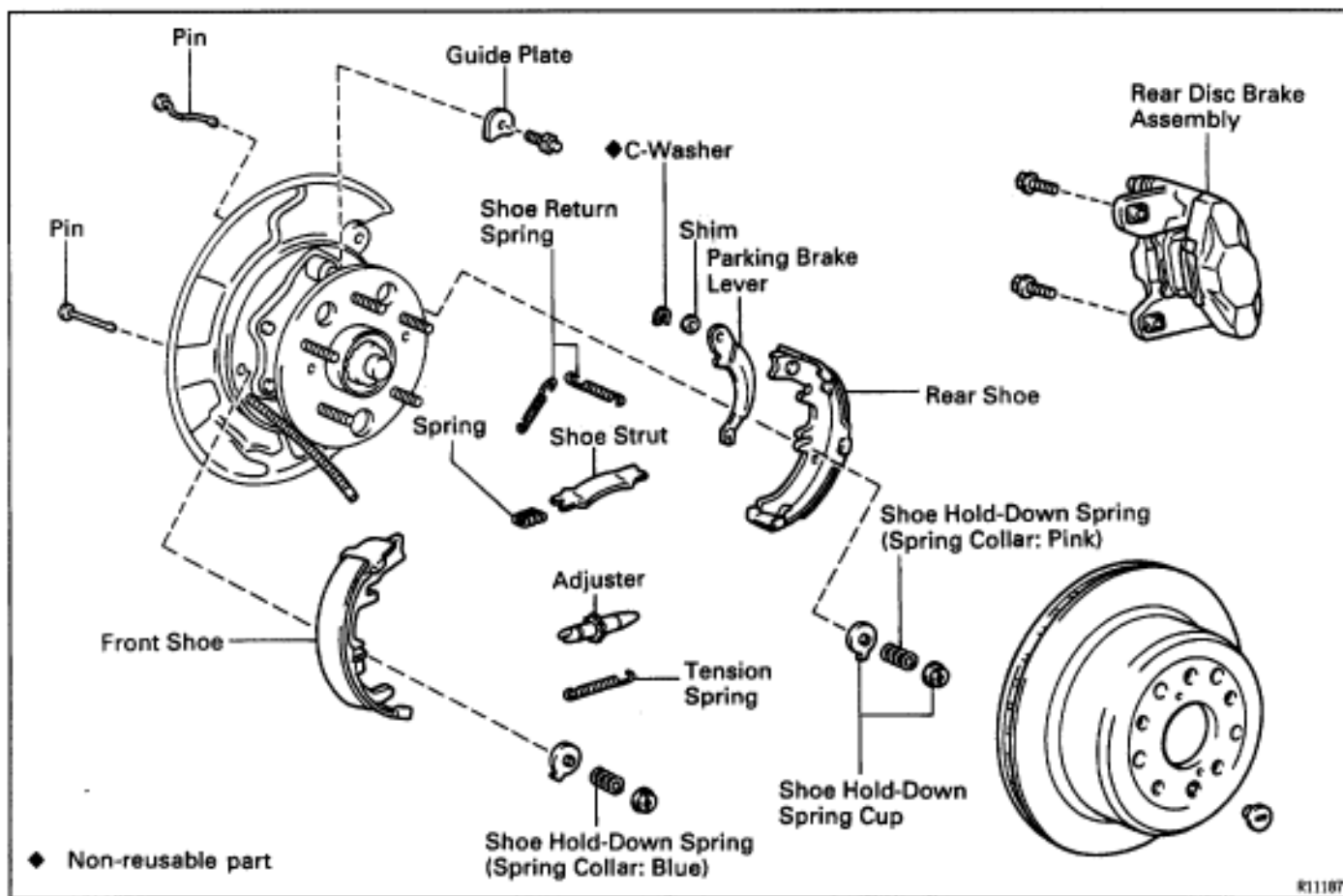

PARKING BRAKE DISASSEMBLY

1. REMOVE REAR WHEEL
2. REMOVE REAR DISC BRAKE ASSEMBLY
 - (a) Remove the 2 mounting bolts and remove the disc brake assembly.
 - (b) Suspend the disc brake securely and so the hose is not stretched.

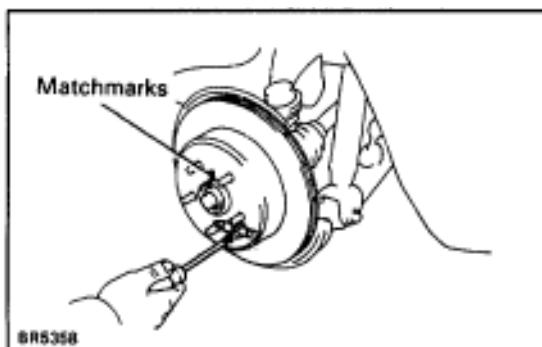

3. REMOVE DISC
 - (a) Place matchmarks on the disc and rear axle hub.
 - (b) Remove the disc.

HINT: If the disc cannot be removed easily, return the shoe adjuster until the disc turns freely.

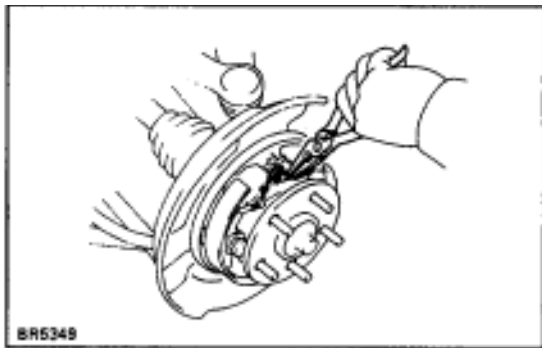

4. REMOVE SHOE RETURN SPRINGS

Using needle-nose pliers, remove the 2 shoe return springs.

5. REMOVE SHOE STRUT WITH SPRING

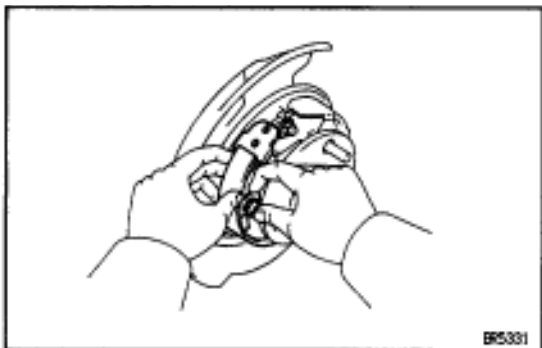

6. REMOVE FRONT SHOE, ADJUSTER AND TENSION SPRING

- (a) Slide out the front shoe and remove the shoe adjuster.
- (b) Disconnect the tension spring and remove the front shoe.

7. REMOVE REAR SHOE

- (a) Slide out the rear shoe.
- (b) Remove the tension spring from the rear shoe.
- (c) Disconnect the parking brake cable from the parking brake shoe lever.
- (d) Remove the shoe hold-down spring cups, springs and pins.

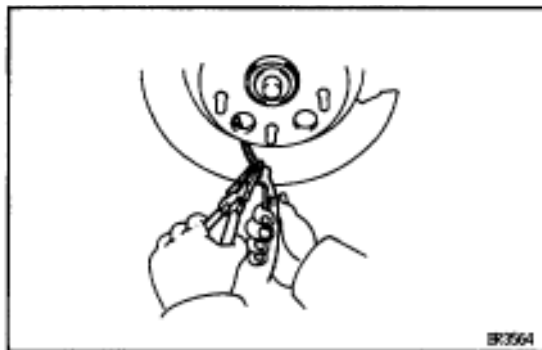

PARKING BRAKE COMPONENTS INSPECTION AND REPAIR

1. INSPECT DISASSEMBLED PARTS

Inspect the disassembled parts for wear, rust or damage.

2. MEASURE BRAKE SHOE LINING THICKNESS

Using a ruler, measure the thickness of the shoe lining.

Standard thickness:

2.5 mm (0.098 in.)

Minimum thickness:

1.0 mm (0.039 in.)

If the lining thickness is at the minimum thickness or less, or if there is severe, uneven wear, replace the brake shoe.

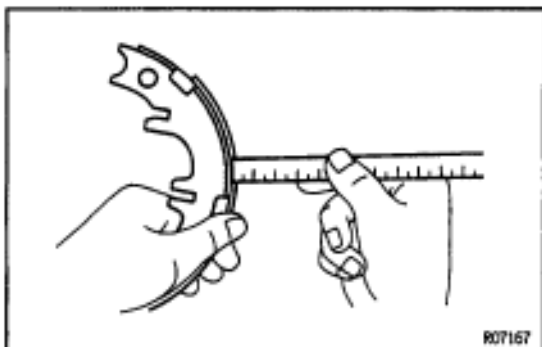

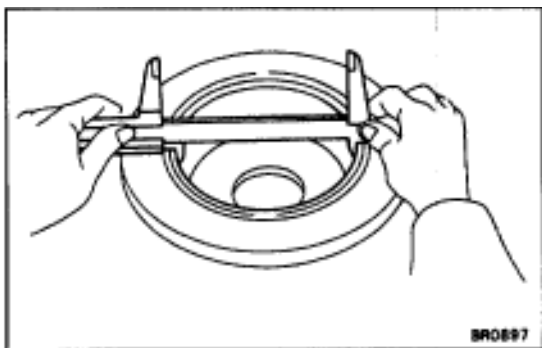

3. MEASURE BRAKE DISC INSIDE DIAMETER

Using a vernier caliper, measure the inside diameter of the disc.

Standard inside diameter:

190 mm (7.48 in.)

Maximum inside diameter:

191 mm (7.52 in.)

Replace the disc if the inside diameter is at the maximum value or more. Replace the disc or grind it with a lathe if the disc is badly scored or worn unevenly.

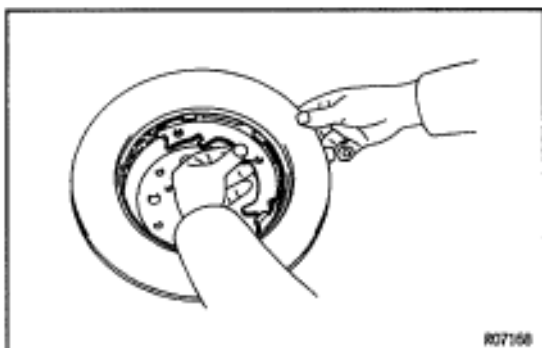

4. INSPECT PARKING BRAKE LINING AND DISC FOR PROPER CONTACT

Apply chalk to the inside surface of the disc, then grind down the brake shoe lining to fit. If the contact between the disc and the brake shoe lining is improper, repair it using a brake shoe grinder or replace the brake shoe assembly.

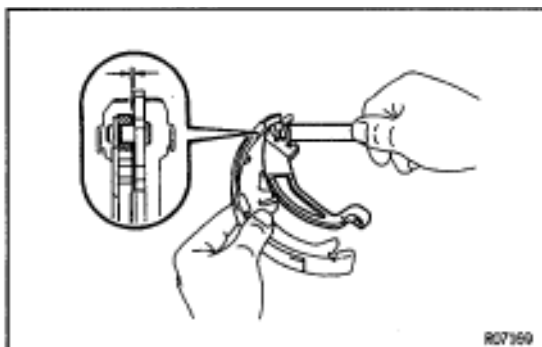

5. MEASURE CLEARANCE BETWEEN PARKING BRAKE SHOE AND LEVER

Using a feeler gauge, measure the clearance.

Standard clearance:

Less than 0.35 mm (0.0138 in.)

If the clearance is not within the specification, replace the shim with one of the correct size.

Thickness	m(in.)	Thickness	mm(in.)
0.3	(0.012)	0.8	(0.031) (2JZ-GTE only)
0.6	(0.024)	0.9	(0.035) (2JZ-GE only)

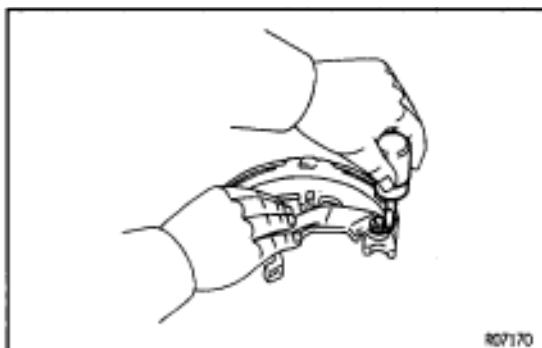

6. IF NECESSARY, REPLACE SHIM

(a) Remove the parking brake shoe lever, and install the correct size shim.

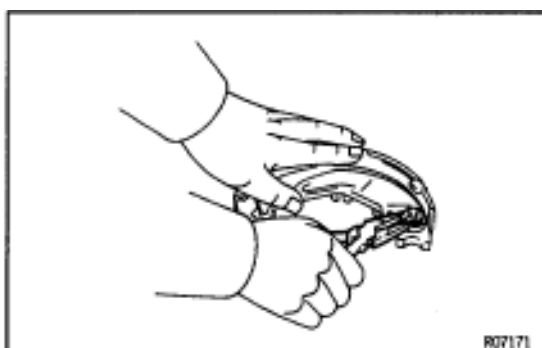

(b) Install the parking brake shoe lever with a new C-washer.

(c) Remeasure the clearance.

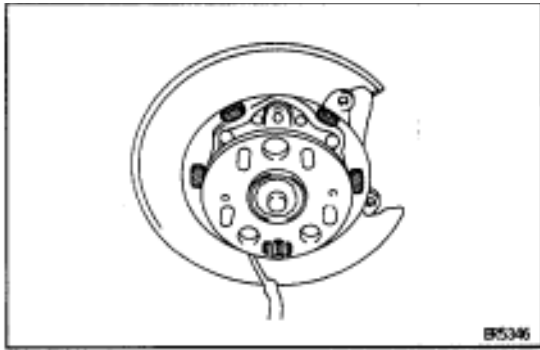

PARKING BRAKE ASSEMBLY

1. APPLY HIGH TEMPERATURE GREASE ON THESE PARTS:

- (a) Rubbing surfaces of the backing plate and shoe

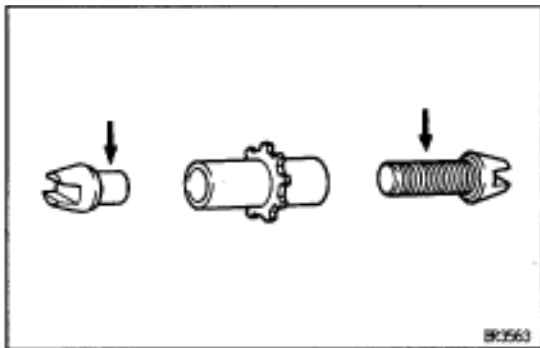

- (b) Adjuster

2. CONNECT PARKING BRAKE CABLE TO PARKING BRAKE LEVER

- (a) Install the shoe hold-down springs, cups and pins.
- (b) Connect the parking brake cable to the parking brake shoe lever of the rear shoe.

3. INSTALL REAR SHOE

Slide in the rear shoe between the shoe hold-down spring cup and the backing plate.

NOTICE: Do not allow oil or grease to get on the rubbing face.

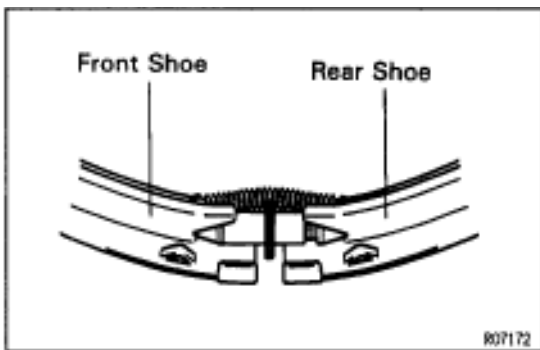

4. INSTALL TENSION SPRING, FRONT SHOE AND ADJUSTER

- (a) Install the tension spring on the rear shoe.
- (b) Install the front shoe on the tension spring.
- (c) Install the adjuster between the front and rear shoes.
- (d) Slide in the front shoe between the shoe hold-down spring cup and the backing plate.

5. INSTALL STRUT WITH SPRING

Install the strut with the spring forward.

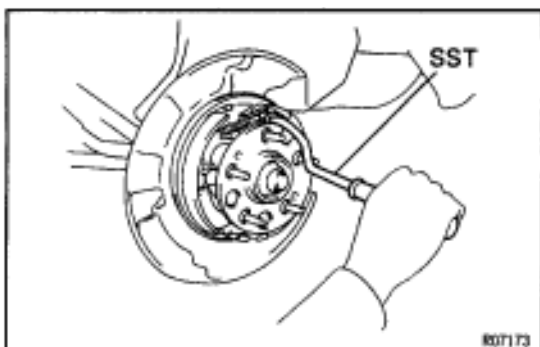

6. INSTALL SHOE RETURN SPRINGS

Using SST, install the front shoe return spring and then install the rear shoe return spring.

SST 09718-20010

7. INSTALL DISC

- (a) Before installing, polish the disc and shoe surfaces with sandpaper.
- (b) Align the matchmarks and install the disc.

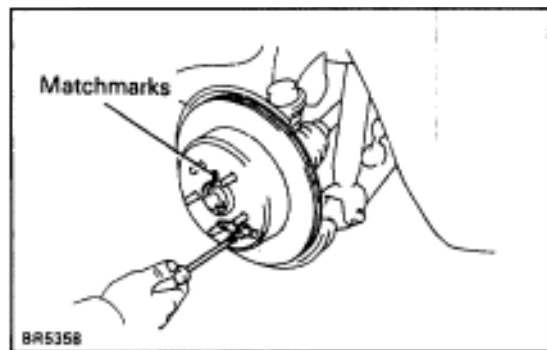

HINT: If there are no matchmarks, temporarily install the disc, then measure the disc runout and install the disc in the position.

(See page [BR-30](#) or [BR-34](#))

8. ADJUST PARKING BRAKE SHOE CLEARANCE

- (a) Temporarily install the hub nuts.
- (b) Remove the hole plug.
- (c) Turn the adjuster and expand the shoes until the disc locks.
- (d) Return the adjuster 8 notches.
- (e) Install the hole plug.

9. INSTALL REAR DISC BRAKE ASSEMBLY

Install the disc brake assembly and torque the 2 mounting bolts.

Torque: 104 N·m (1,065 kgf·cm, 77 ft·lbf)

10. INSTALL REAR WHEEL

11. SETTLING PARKING BRAKE SHOES AND DISC

- (a) Drive the vehicle at about 50 km/h (31mph) on a safe, level and dry road.
- (b) With the parking brake release button pushed in, pull on the lever with 88 N (9 kgf, 19.8 lbf) of force.
- (c) Drive the vehicle for about 400 meters (0.25 mile) in this condition.
- (d) Repeat this procedure 2 or 3 times.

12. CHECK AND ADJUST PARKING BRAKE LEVER TRAVEL

PROPORTIONING AND BY-PASS VALVE (P & B VALVE) FLUID PRESSURE INSPECTION

1. INSTALL LSPV GAUGE (SST) AND BLEED AIR
SST 09709-29017

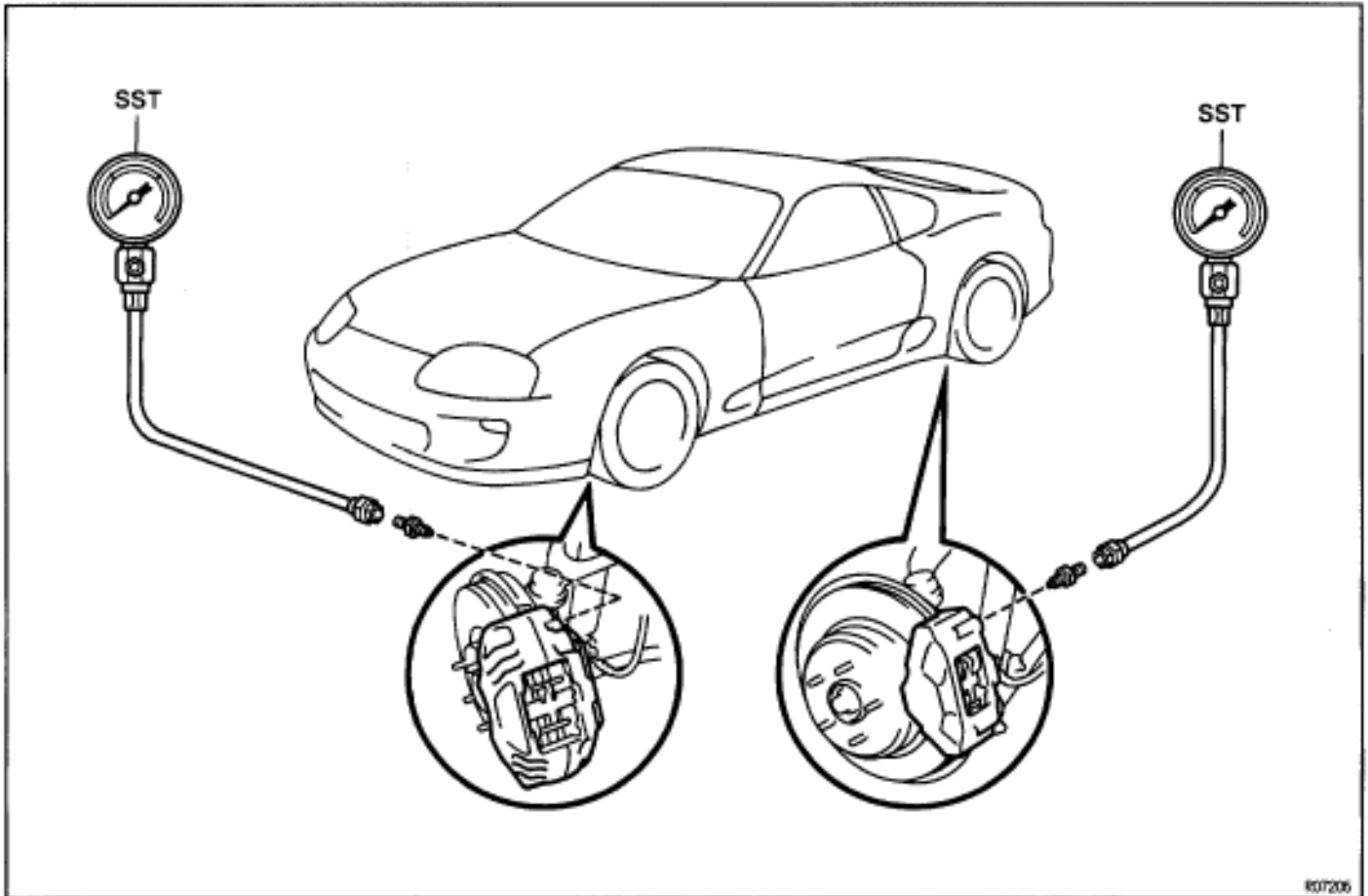

2. RAISE MASTER CYLINDER PRESSURE AND CHECK REAR WHEEL CYLINDER PRESSURE
2JZ-GTE:

Master cylinder pressure	Rear wheel cylinder pressure
2,452 kPa (25 kgf/cm ² , 356 psi)	2,452 kPa (25 kgf/cm ² , 356 psi)
7,845 kPa (80 kgf/cm ² , 1,138 psi)	4,452 kPa (45.4 kgf/cm ² , 646 psi)

2JZ-GE:

Master cylinder pressure	Rear wheel cylinder pressure
2,942 kPa (30 kgf/cm ² , 427 psi)	2,942 kPa (30 kgf/cm ² , 427 psi)
7,845 kPa (80 kgf/cm ² , 1,138 psi)	4,756 kPa (48.5 kgf/cm ² , 690 psi)

Specifications: If the rear wheel cylinder pressure is incorrect, replace the master cylinder.

- 3. BLEED BRAKE SYSTEM (See page [BR-7](#))**
- 4. CHECK FOR FLUID LEAKAGE**

ANTI-LOCK BRAKE SYSTEM (ABS) ABS ACTUATOR COMPONENTS

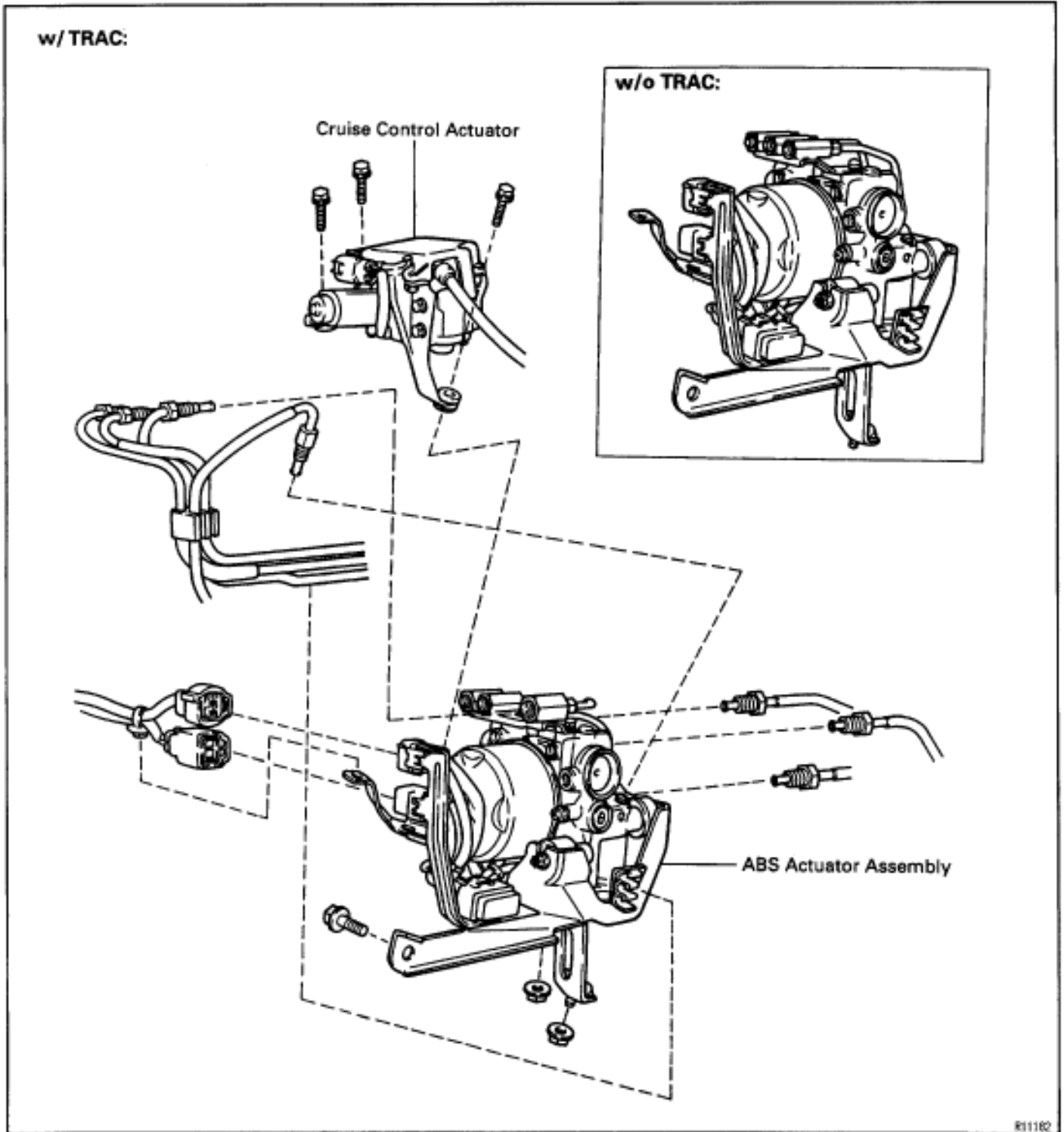

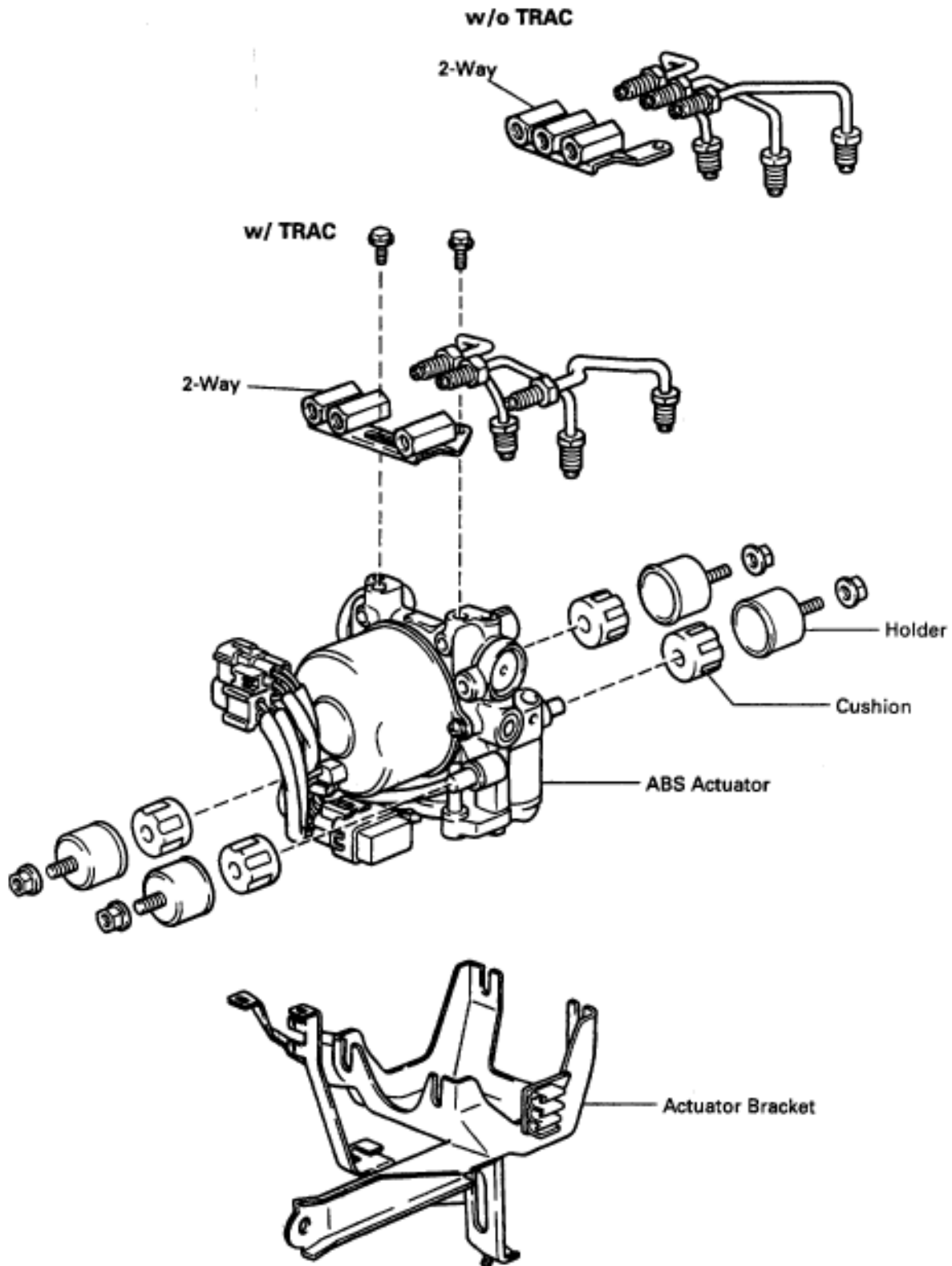

ABS ACTUATOR REMOVAL

Installation is in the reverse order of removal.

AFTER INSTALLATION, BLEED BRAKE SYSTEM (See page BR-7) AND BLEED TRAC SYSTEM (See page BR-9)

1. REMOVE CRUISE CONTROL ACTUATOR

Remove the 3 bolts and cruise control actuator.

Torque:

Cruise control actuator X Body

13 N·m (130 kgf·cm, 9 ft·lbf)

Cruise control actuator X ABS actuator X Body

19 N·m (195 kgf·cm, 14 ft·lbf)

2. DISCONNECT BRAKE LINES

Using SST, disconnect the brake lines from the ABS actuator.
SST 09751-36011

Torque:

M10: 15 N·m (155 kgf·cm, 11 ft·lbf)

M12: 20 N·m (200 kgf·cm, 15 ft·lbf)

3. DISCONNECT CONNECTORS

Disconnect the 2 connectors and wire harness clamp from the bracket.

4. REMOVE ABS ACTUATOR ASSEMBLY

Remove the bolt, 2 nuts and ABS actuator assembly.

Torque: 19 N·m (195 kgf·cm, 14 ft·lbf)

5. REMOVE 2-WAY

(a) Using SST, remove the 3 brake line.

SST 09751-36011

Torque: 15 N·m (155 kgf·cm, 11 ft·lbf)

(b) Remove the 2 bolt and 2 way.

Torque: 8.8 N·m (90 kgf·cm, 78 in·lbf)

6. REMOVE ABS ACTUATOR

Remove the 4 nuts and actuator from bracket.

Torque: 5.4 N·m (55 kgf·cm, 48 in·lbf)

7. REMOVE 4 CUSHIONS AND HOLDERS

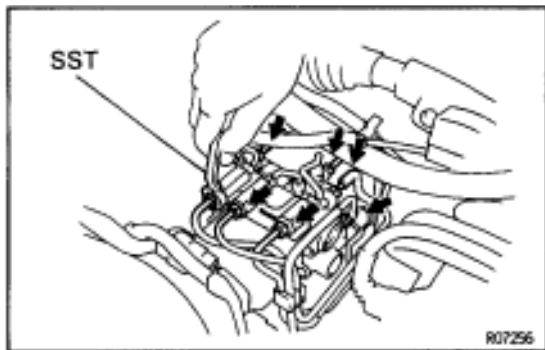

ABS ACTUATOR INSPECTION

w / TRAC HINT: Using the ABS actuator checker (SST), check the operation of the actuator. If the actuator does not operate, check the operation of sub-wire harness G according to instructions on pages BR-65 and BR-71. If the solenoid and/or pump motor relay are abnormal, replace the relay and inspect the actuator operation again.

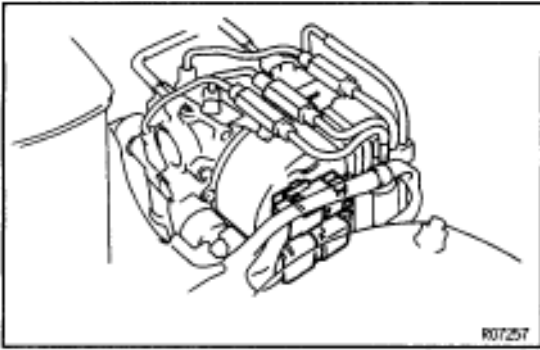

1. INSPECT BATTERY POSITIVE VOLTAGE

Battery positive voltage:

10–14 V

2. DISCONNECT CONNECTORS

(a) Disconnect the 2 connectors from the actuator.

(b) w/o TRAC:

Disconnect the 2 connectors from the control relay.

3. CONNECT ACTUATOR CHECKER (SST) TO ACTUATOR

(a) Connect the actuator checker (SST) to the actuator side wire harnesses via the sub-wire harnesses (SST), as shown.

w/o TRAC:

SST 09990-00150, 09990-00200, and 09990-00210

w/ TRAC:

SST 09990-00150, 09990-00210, 09990-00250, and 09990-00280

(b) Connect the red cable of the checker to the battery positive (+) terminal and the black cable to negative (-) terminal. Connect the black cable of the sub-wire harnesses to the battery negative (-) terminal or body ground.

SST 09990-00163

(c) Place "SHEET A" (SST) on the actuator checker.

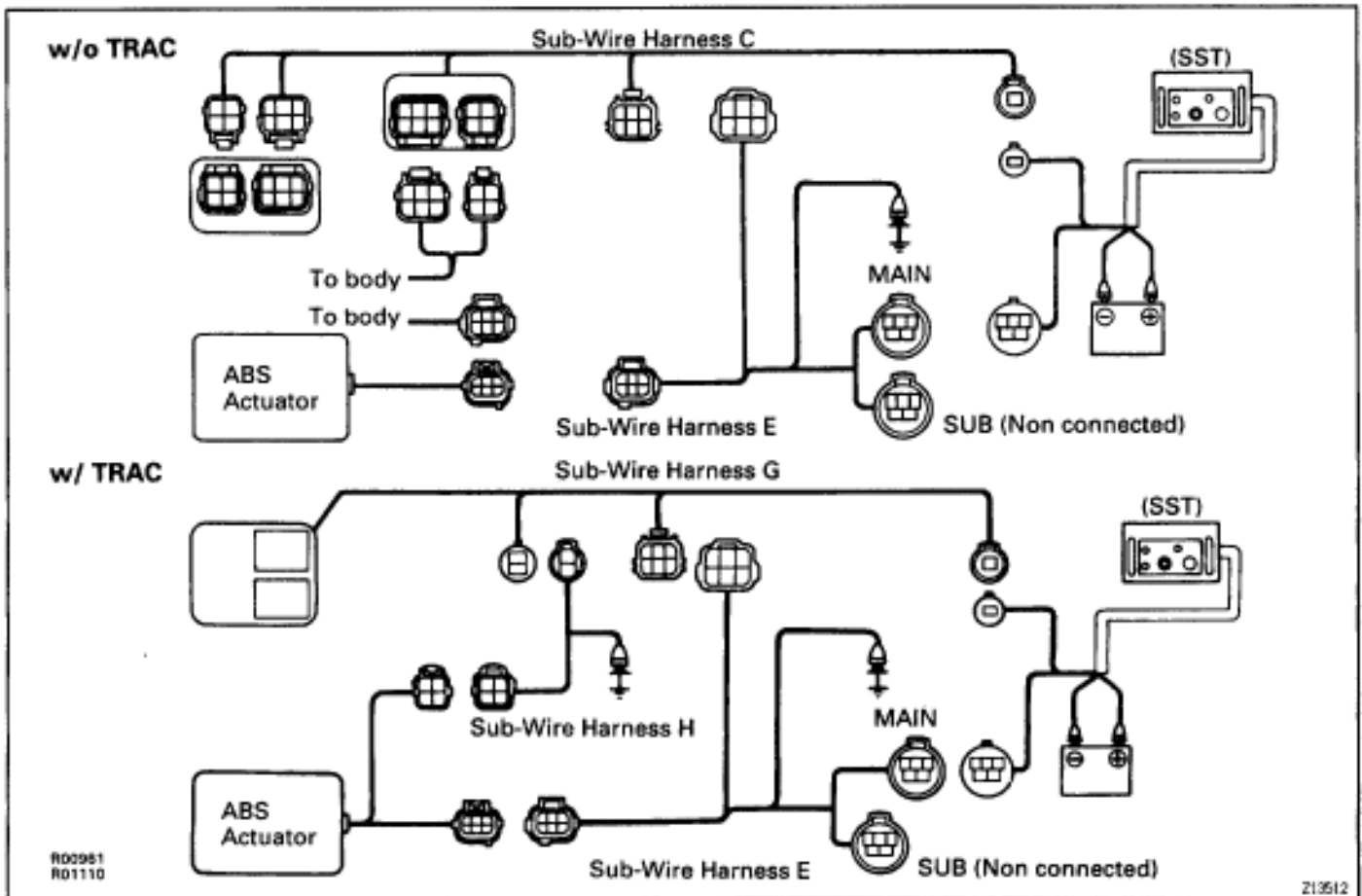

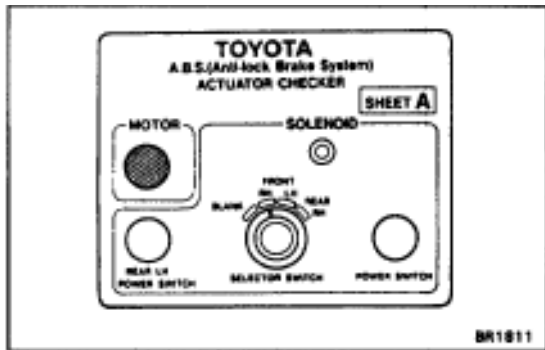

4. INSPECT BRAKE ACTUATOR OPERATION

- Start the engine, and run it at idle speed.
- Turn the selector switch of the actuator checker to the "FRONT RH" position.
- Push and hold in the MOTOR switch for a few seconds.
- Depress the brake pedal and hold it until step (g) is completed.

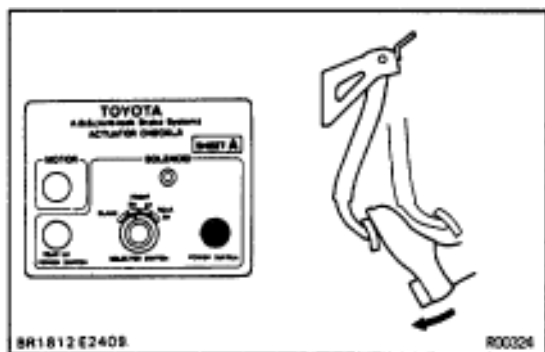

- Push the POWER SWITCH, and check that the brake pedal cannot be depressed.
NOTICE: Do not keep the MAIN switch pushed down for more than 10 seconds.
- Release the switch, and check that the pedal can be depressed.

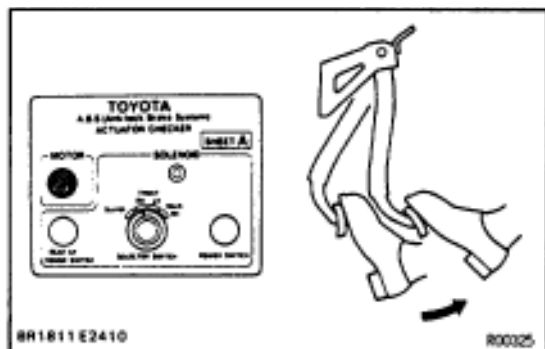

- Push and hold in the MOTOR switch for a few seconds, and check that the pedal returns.
- Release the brake pedal.

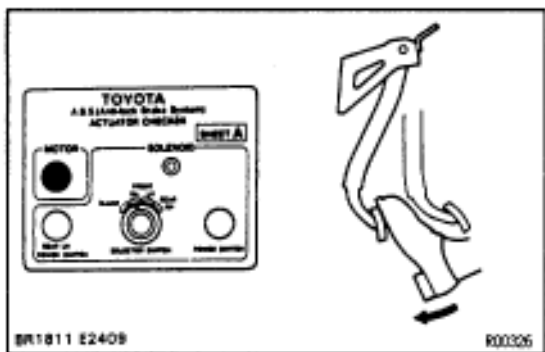

- Push and hold in the MOTOR switch for a few seconds.
- Depress the brake pedal and hold it for about 15 seconds. As you hold the pedal down, push the MOTOR switch for a few seconds. Check that the brake pedal does not pulsate.

5. INSPECT FOR OTHER WHEELS

- Turn the selector switch to the "FRONT LH" position.
- Repeat (c) to (j) of step 4, checking the actuator operation in the same way.
- Also, inspect the "REAR RH" and "REAR LH" positions following the same procedure.

HINT: When inspecting the "REAR LH" position, push the REAR LH switch instead of the POWER SWITCH. This makes it possible to inspect wherever the selector switch position indicates.

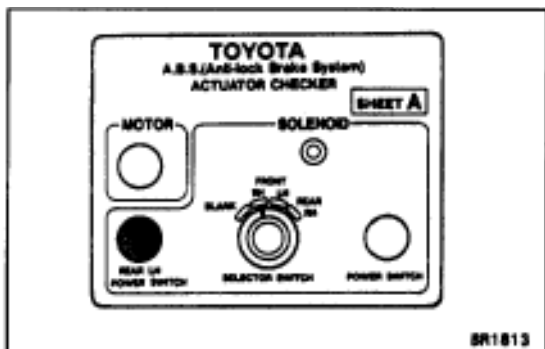

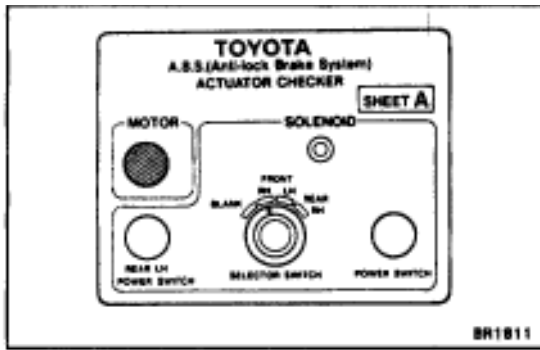

6. PUSH MOTOR SWITCH

Push and hold in the MOTOR switch for a few seconds.

7. DISCONNECT ACTUATOR CHECKER (SST) FROM ACTUATOR

Disconnect the actuator checker (SST) and sub-wire harnesses (SST) from the actuator.

w/o TRAC:

SST 09990-00150, 09990-00163, 09990-00200,
and 09990-00210

w/ TRAC:

SST 09990-00150, 09990-00163, 09990-00210,
09990-00250 and 09990-00280

8. CONNECT CONNECTORS

(a) Connect the 2 connectors to the actuator.

(b) w/o TRAC:

Connect the 2 connectors to the control relay.

9. CLEAR DIAGNOSTIC TROUBLE CODES

(See page [BR-55](#))

FRONT SPEED SENSOR COMPONENTS

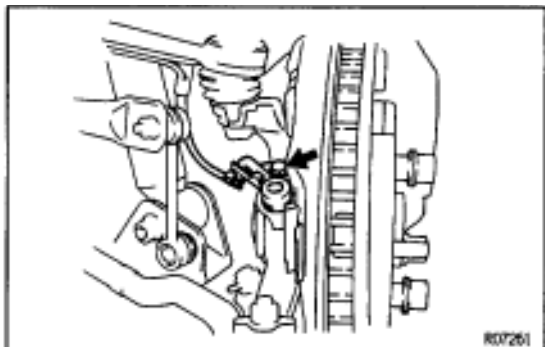
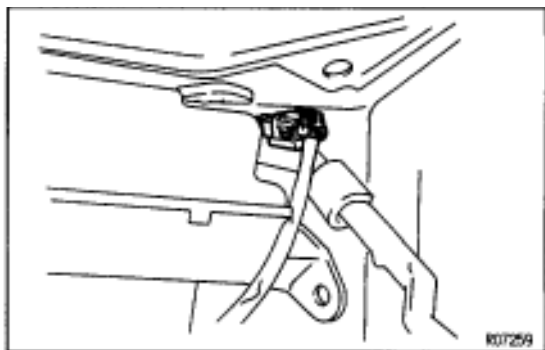
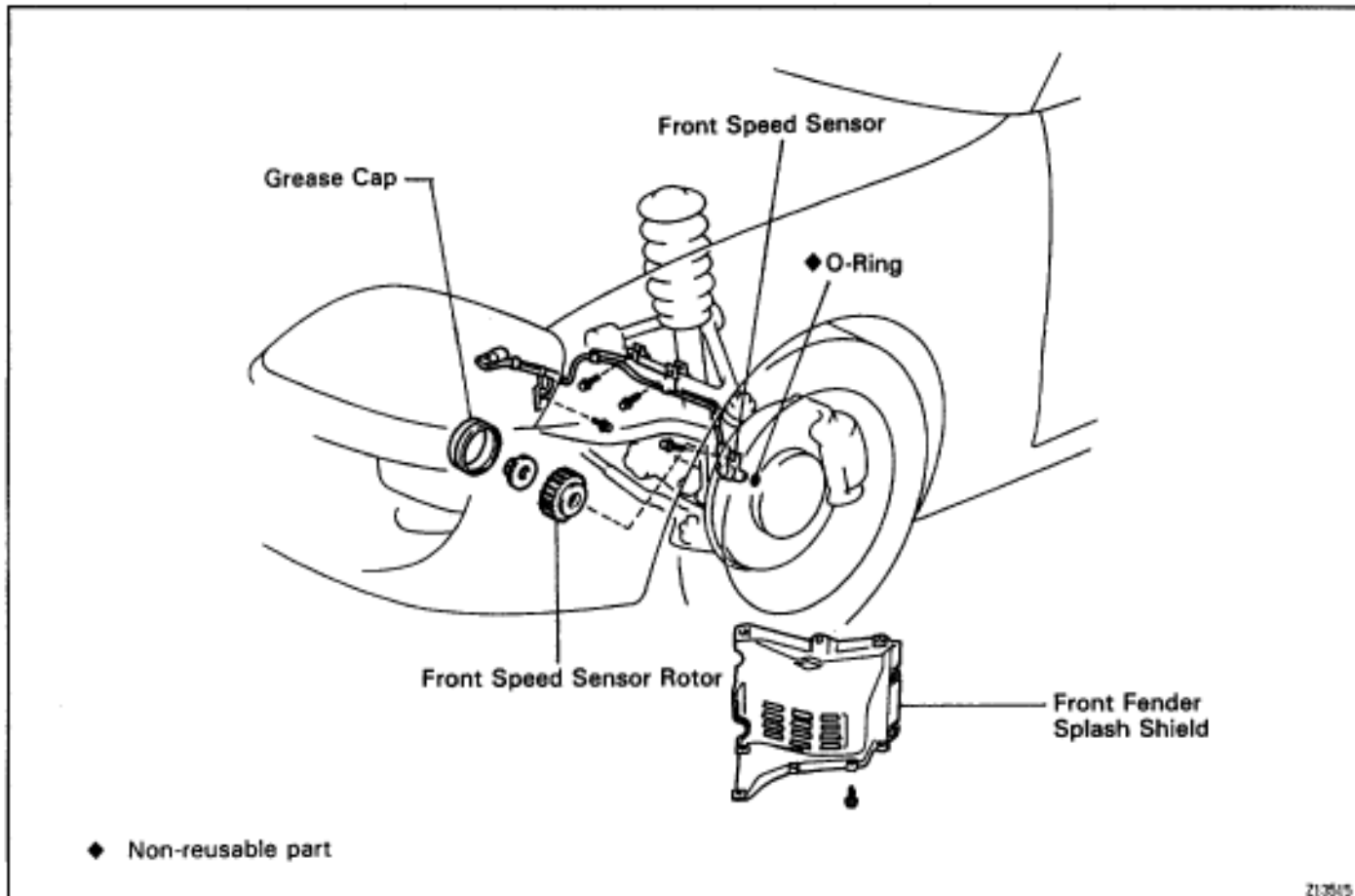

FRONT SPEED SENSOR REMOVAL

Installation is in the reverse order of removal.

AFTER INSTALLATION, CHECK SPEED SENSOR SIGNAL (See page BR-62)

1. DISCONNECT CONNECTOR

- (a) Remove the front fender splash shield.
- (b) Disconnect the speed sensor connector.

2. REMOVE SPEED SENSOR

- (a) Remove the 3 clamp bolts holding the sensor harness to the body and upper suspension arm.
Torque: 5.4 N·m (55 kgf·cm, 48 in·lbf)
- (b) Remove the speed sensor from the steering knuckle.
Torque: 7.8 N·m (80 kgf·cm, 69 in·lbf)
- (c) Remove the O-ring from the speed sensor.

REAR SPEED SENSOR COMPONENTS

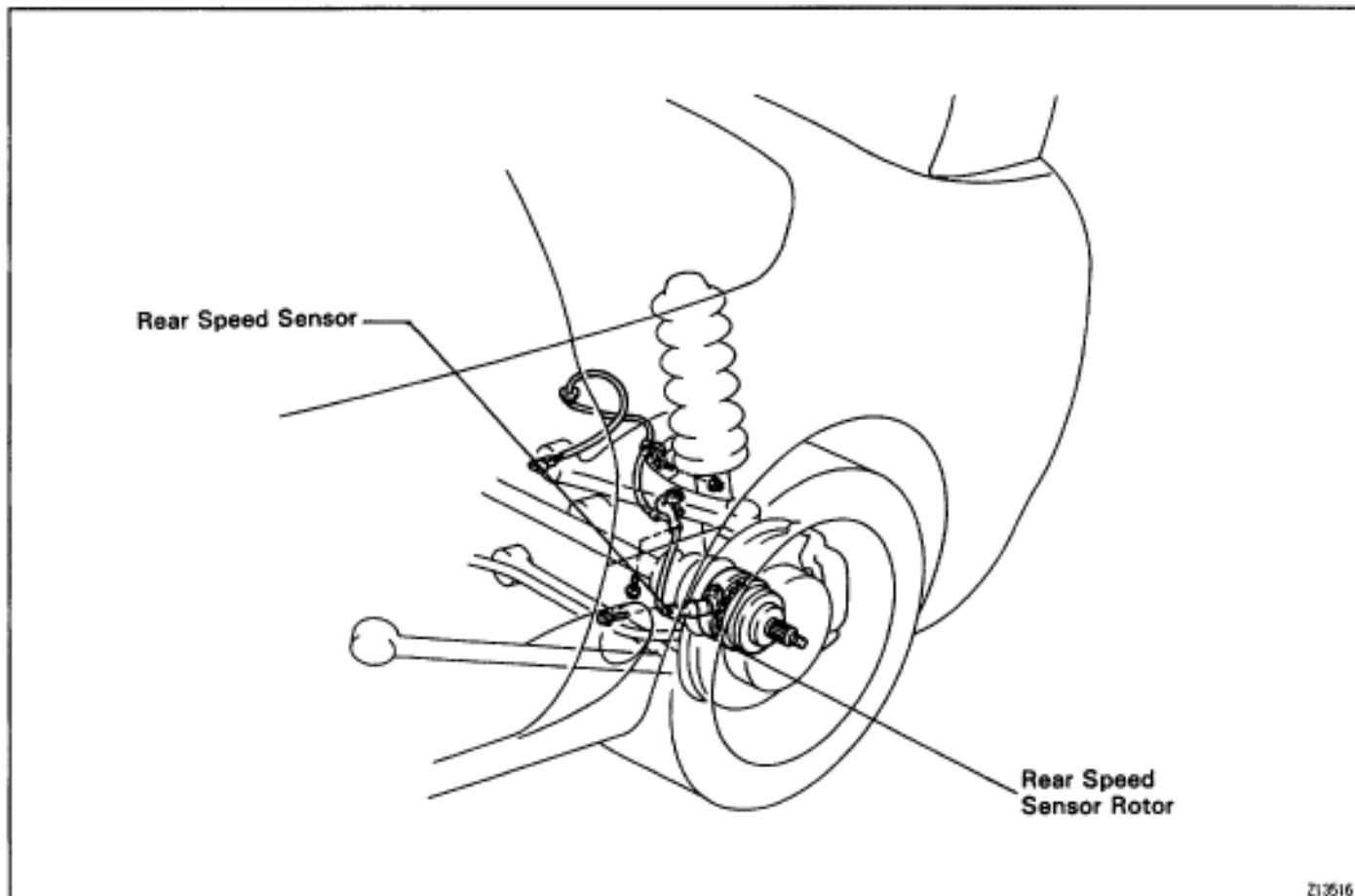

Z13516

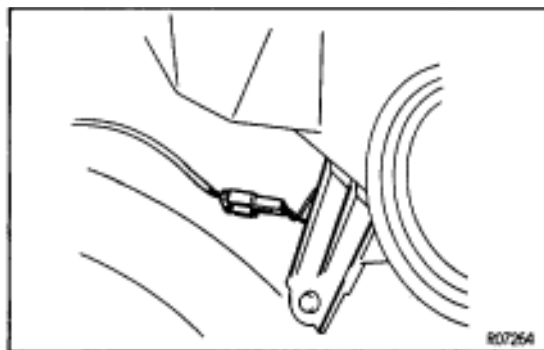

R07264

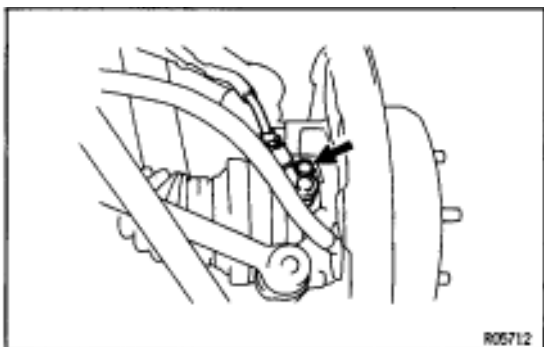

R05712

REAR SPEED SENSOR REMOVAL

Installation is in the reverse order of removal.

AFTER INSTALLATION, CHECK SPEED SENSOR SIGNAL (See page BR-62)

1. DISCONNECT SPEED SENSOR CONNECTOR

- (a) Remove the rear seat cushion and seat back.
- (b) Remove the quarter trim panel.
- (c) Disconnect the speed sensor connector, and pull out the sensor wire harness with the grommet.

2. REMOVE SPEED SENSOR

- (a) Remove the 2 clamp bolts holding the sensor wire harness to the body and upper arm.
Torque: 5.4 N·m (55 kgf·cm, 48 in.·lbf)
- (b) Remove the speed sensor from the axle carrier.
Torque: 7.8 N·m (80 kgf·cm, 69 in.·lbf)

-MEMO-

TROUBLESHOOTING

HOW TO PROCEED WITH TROUBLESHOOTING

Perform troubleshooting in accordance with the procedure on the following pages.

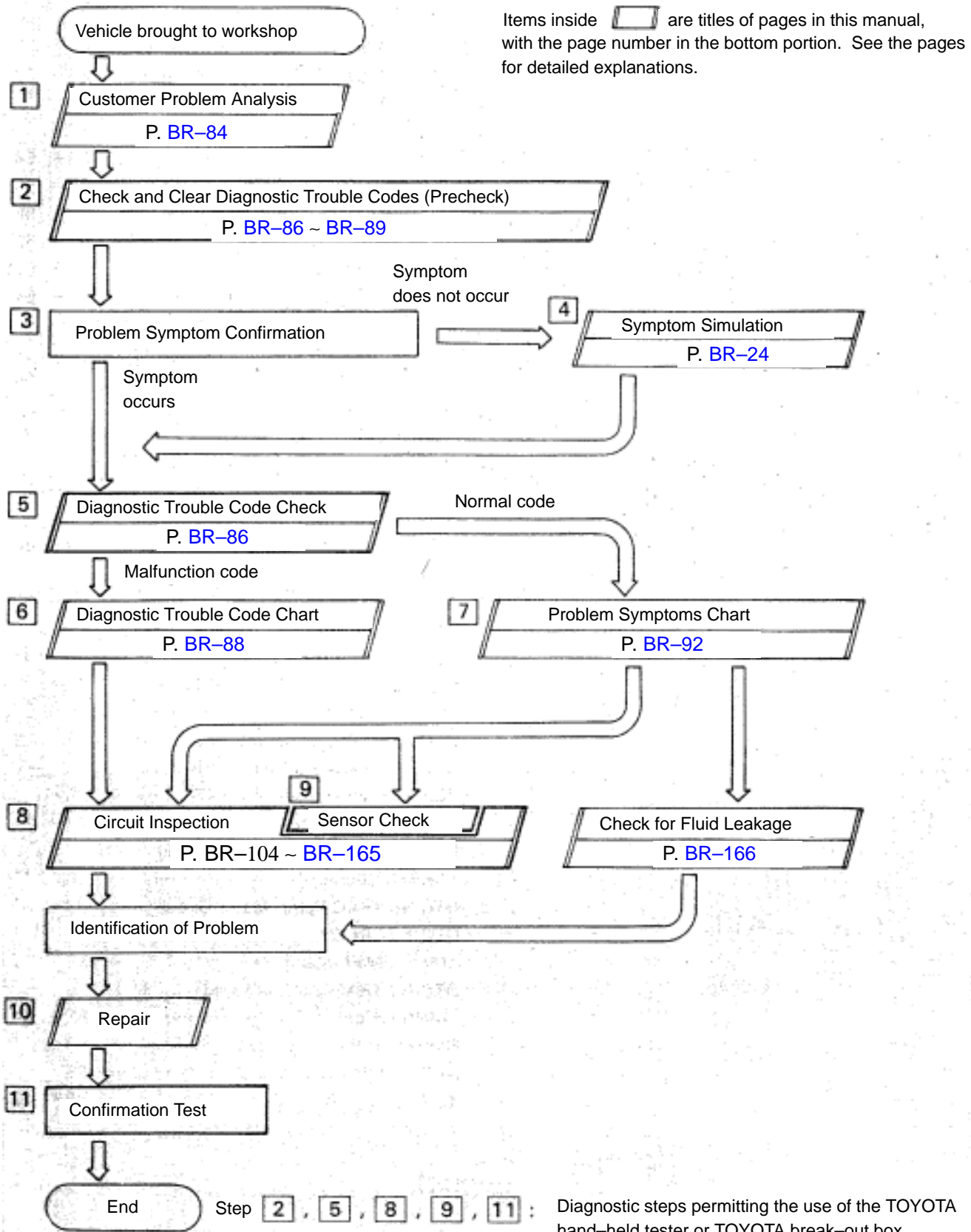

CUSTOMER PROBLEM ANALYSIS CHECK SHEET

ABS Check Sheet

 Inspector's
Name

Customer's Name		Registration No.	
		Registration Year	/ /
		Frame No.	
Date Vehicle Brought In	/ /	Odometer Reading	km Miles

Date Problem First Occurred	/ /
Frequency Problem Occurs	<input type="checkbox"/> Continuous <input type="checkbox"/> Intermittent (times a day)

Symptoms	<input type="checkbox"/> ABS does not operate.	
	<input type="checkbox"/> ABS does not operate efficiently.	
	ABS Warning Light Abnormal	<input type="checkbox"/> Remains ON <input type="checkbox"/> Does not Light Up

Check Item	TRAC Indicator Light	<input type="checkbox"/> Normal <input type="checkbox"/> Does not Light Up
------------	----------------------	--

Diagnostic Trouble Code Check	1st Time	<input type="checkbox"/> Normal Code <input type="checkbox"/> Malfunction Code (Code)
	2nd Time	<input type="checkbox"/> Normal Code <input type="checkbox"/> Malfunction Code (Code)

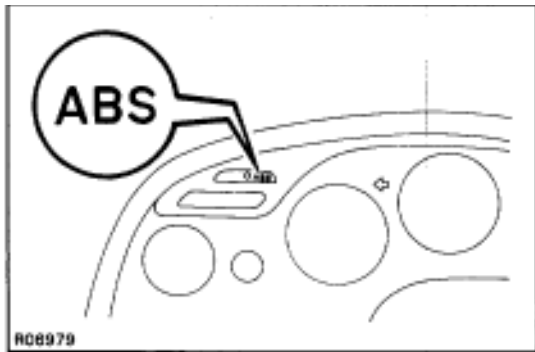

DIAGNOSIS SYSTEM INDICATOR CHECK

When the ignition switch is turned ON, check that the ABS warning light goes on for 3 seconds.

HINT: If the indicator check result is not normal, proceed to troubleshooting for the ABS warning light circuit (See page [BR-107](#))

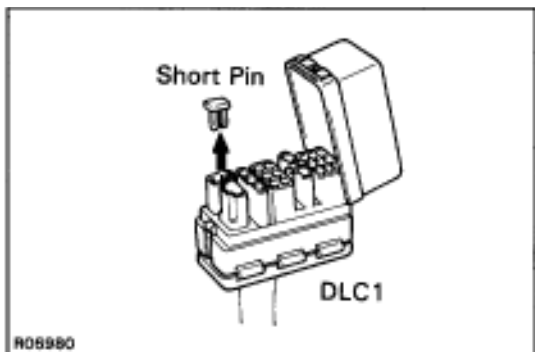

DIAGNOSTIC TROUBLE CODE CHECK

1. Turn the ignition switch ON.
2. Disconnect the Short Pin from DLC1.

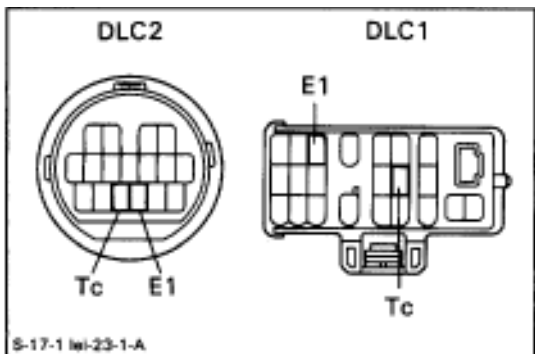

3. Using SST, connect terminals Tc and E1 of DLC2 or DLC1. SST 09843-18020
4. Read the diagnostic trouble code from the ABS warning light on the combination meter.

HINT: If no code appears, inspect the diagnostic circuit or ABS warning light circuit (See page [BR-112](#) or [BR-107](#)).

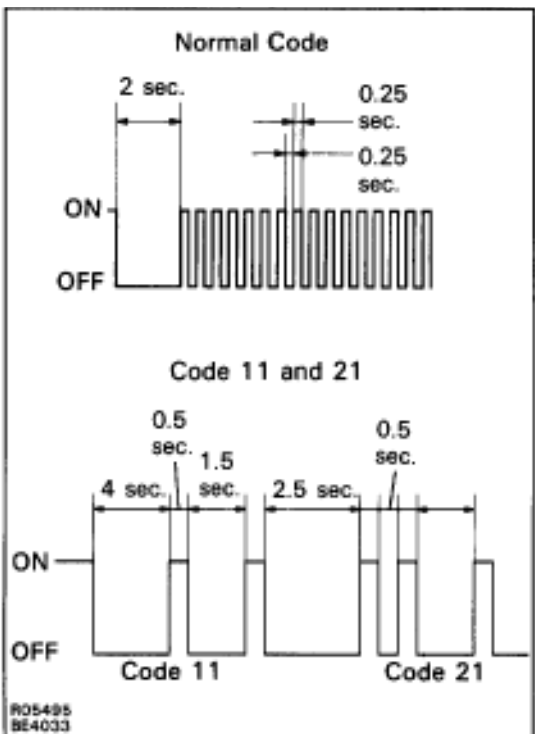

As an example, the blinking patterns for normal code and codes 11 and 21 are shown on the left.

5. Codes are explained in the code table on page [BR-56](#).
6. After completing the check, disconnect terminals Tc and E1, and turn off the display.

If 2 or more malfunctions are indicated at the same time, the lowest numbered diagnostic trouble code will be displayed first.

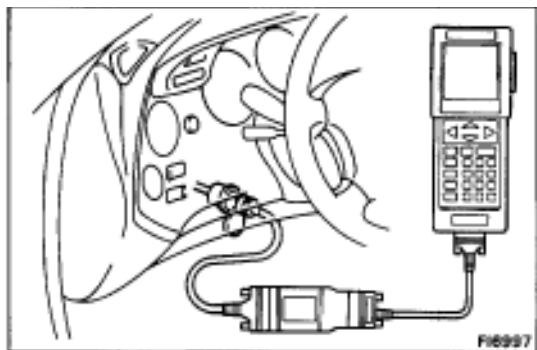

ECU DATA MONITOR USING TOYOTA HAND-HELD TESTER

1. Hook up the TOYOTA hand-held tester to the DLC2.
2. Monitor the ECU data by following the prompts on the scan tool screen.

HINT: TOYOTA hand-held tester has a "Snapshot" function which records the monitored data.

Please refer to the TOYOTA hand-held tester operator's manual for further details.

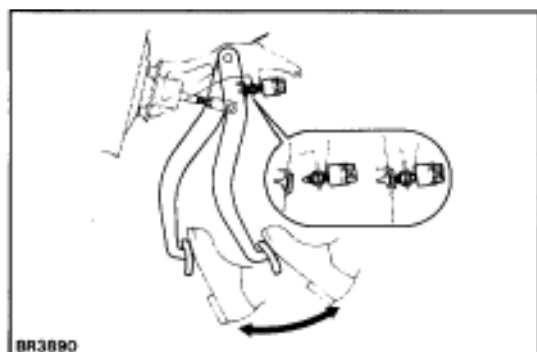

DIAGNOSTIC TROUBLE CODE CLEARANCE

1. Using SST, connect terminals Tc and E1 of DLC2 or DLC1. SST 09843-18020
2. IG switch ON.
3. Clear the diagnostic trouble codes stored in ECU by depressing the brake pedal 8 or more times within 3 seconds.
4. Check that the warning light shows the normal code.
5. Remove the SST from the terminals of DLC2 or DLC1.
6. Connect the Short Pin to DLC1.

HINT: Cancellation can also be done by removing the ECU-B fuse, but in this case, other memory systems will also be cancelled out.

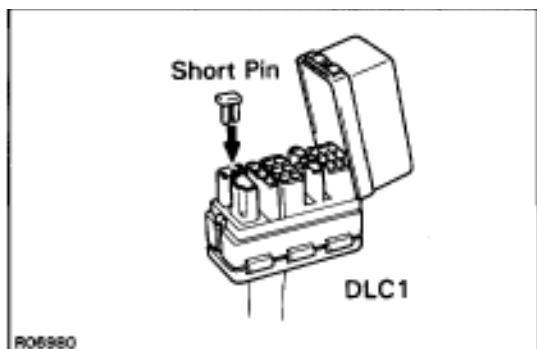

ECU TERMINAL VALUES MEASUREMENT USING TOYOTA BREAK-OUT-BOX AND TOYOTA HAND-HELD TESTER

1. Hook up the TOYOTA hand-held tester and TOYOTA break-out-box to the vehicle.
2. Read the ECU input/output values by following the prompts on the tester screen.

HINT: TOYOTA hand-held tester has a "Snapshot" function. This records the measured values and is effective in the diagnosis of intermittent problems.



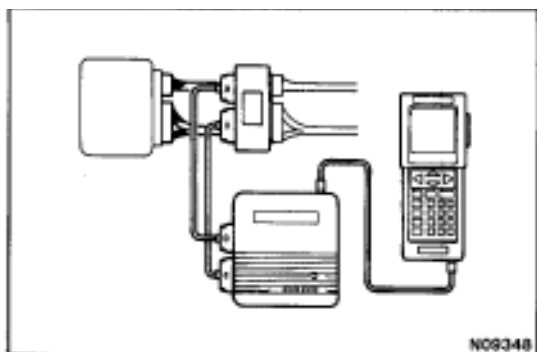















Please refer to the TOYOTA hand-held tester/TOYOTA break-out-box operators manual for further details.











DIAGNOSTIC TROUBLE CODE CHART

If a malfunction code is displayed during the diagnostic trouble code check, check the circuit listed for that code in the table below and proceed to the relevant page.

HINT: Using SST 09843-18020, connect the terminals Tc and E₁, and remove the short pin.

Code	ABS Warning Light Blinking Pattern	Indicator			Diagnosis	See page
		ABS Warning Light	TRAC Indicator Light	TRAC OFF Light		
11	 BE3931	ON	OFF	ON	Open or short in ABS solenoid relay circuit	BR-65
12	 BE3931	ON	OFF	ON	B+ short in ABS solenoid relay circuit	BR-65
13	 BE3931	ON	OFF	ON	Open or short in ABS motor relay circuit	BR-71
14	 BE3931	ON	OFF	ON	B+ short in ABS motor relay circuit	BR-71
15	 BE3931	ON	ON	ON	Open or short in TRAC solenoid relay circuit	BR-77
16	 BE3931	ON	ON	OFF	B+ short in TRAC solenoid relay circuit	BR-77
17	 BE3931	OFF*	ON	ON	Open or short in TRAC motor relay circuit	BR-80
18	 BE3931	OFF*	ON	ON	B+ short in TRAC motor relay circuit	BR-80
21	 BE3932	ON	OFF	ON	Open or short in ABS actuator solenoid circuit (SFR circuit)	BR-83
22	 BE3932	ON	OFF	ON	Open or short in ABS actuator solenoid circuit (SFL circuit)	BR-83
23	 BE3932	ON	OFF	ON	Open or short in ABS actuator solenoid circuit (SRR circuit)	BR-83
24	 BE3932	ON	OFF	ON	Open or short in ABS actuator solenoid circuit (SRL circuit)	BR-83
25	 BE3932	ON	ON	ON	Open or short in TRAC actuator solenoid circuit (SMC circuit)	BR-86
27	 BE3932	ON	ON	ON	Open or short in TRAC actuator solenoid circuit (SRC circuit)	BR-86
31	 BE3933	ON	OFF	ON	Right front wheel speed sensor signal malfunction	BR-88
32	 BE3933	ON	OFF	ON	Left front wheel speed sensor signal malfunction	BR-88
33	 BE3933	ON	OFF	ON	Right rear wheel speed sensor signal malfunction	BR-88
34	 BE3933	ON	OFF	ON	Left rear wheel speed sensor signal malfunction	BR-88

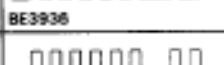
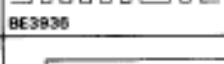
Code	ABS Warning Light Blinking Pattern	Indicator			Diagnosis	See page
		ABS Warning Light	TRAC Indicator Light	TRAC OFF Light		
35		ON	OFF	ON	Open circuit in left front or right rear speed sensor circuit	BR-88
36		ON	OFF	ON	Open circuit in right front or left rear speed sensor circuit	BR-88
41		ON	OFF	ON	Low battery positive voltage or abnormally high battery positive voltage	BR-92
44		ON	OFF	OFF	Open or short in lateral acceleration sensor circuit	BR-95
51		ON	OFF	ON	ABS pump motor is locked Open in ABS pump motor ground	BR-97
55		OFF*	ON	ON	Brake fluid reservoir level low	BR-98
58		OFF*	ON	ON	Open circuit in TRAC pump motor circuit	BR-100
61		OFF*	ON	ON	TRAC ECU communication abnormal	BR-102
62		OFF*	ON	ON	Wheel speed sensor signal malfunction	BR-104
Always ON		ON	ON	ON	Malfunction in ABS (& TRAC) ECU	-

: Only vehicles with TRAC

*: When a malfunction causing code No. 17, 18, 55, 58, 61 or 62 is detected, the ABS warning light does not light up, but the TRAC indicator light does. However, when checking the DTC, check the blinking pattern of the ABS warning light.

PARTS LOCATION

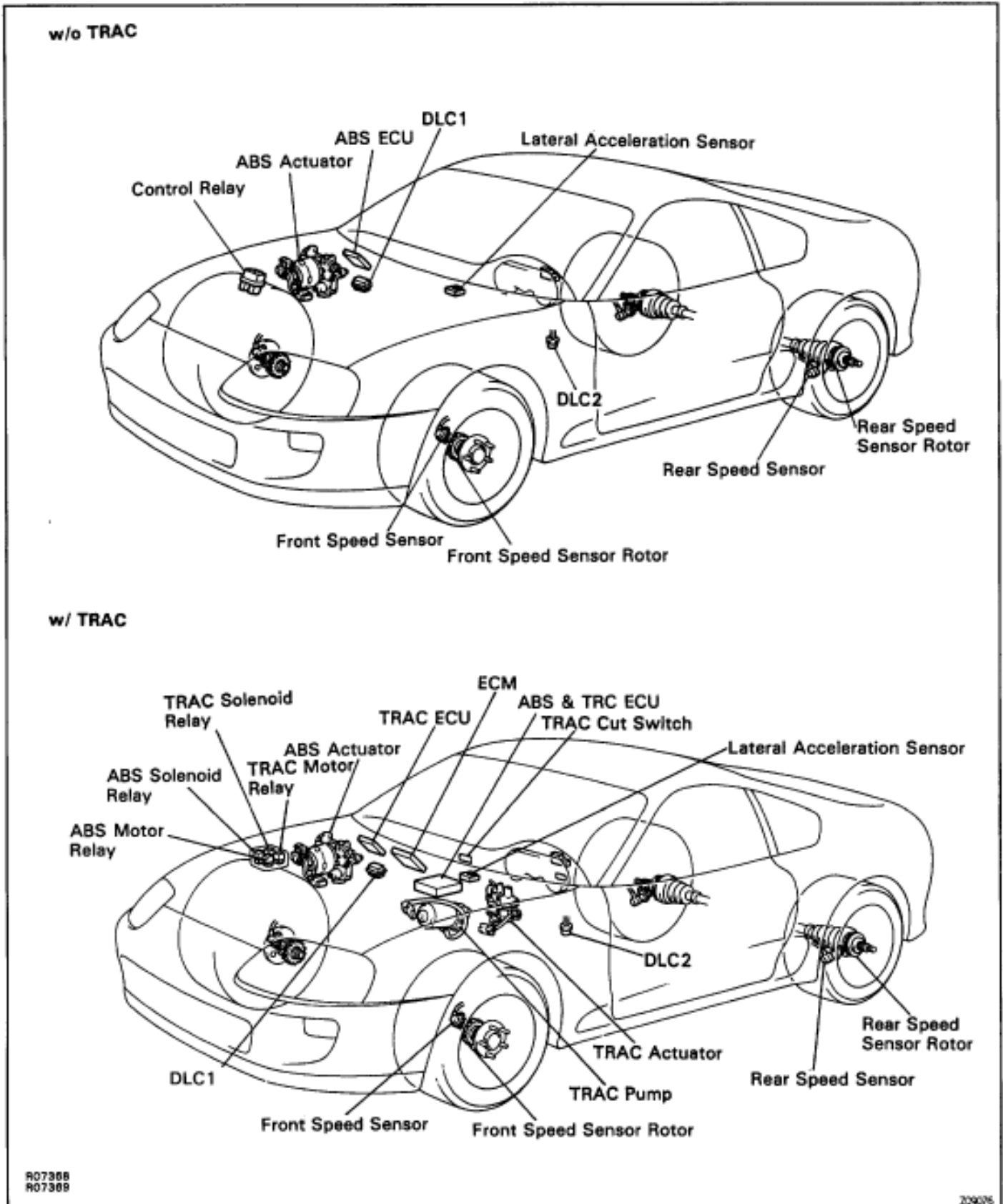

ECU TERMINALS STANDARD VALUE

w/o TRAC:

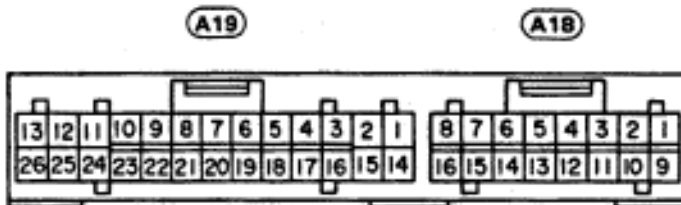

R06396

Symbols (Terminals No.)	STD Voltage (V)	Condition
BAT (A19-25) - GND (A19-15)	10 - 14	Always
IG 1 (A19-12) - GND (A19-2)	10 - 14	IG switch ON
SR (A19-11) - R- (A19-24)	9 - 14	IG switch ON, ABS warning light OFF
MR (A19-23) - R- (A19-24)	Below 1.0	IG switch ON
SFR (A19-1) - GND (A19-2)	10 - 14	IG switch ON, ABS warning light OFF
SFL (A19-13) - GND (A19-2)	10 - 14	IG switch ON, ABS warning light OFF
SRR (A19-26) - GND (A19-15)	10 - 14	IG switch ON, ABS warning light OFF
SRL (A19-14) - GND (A19-15)	10 - 14	IG switch ON, ABS warning light OFF
AST (A19-18) - GND (A19-15)	10 - 14	IG switch ON, ABS warning light OFF
WA (A18-13) - GND (A19-15)	Below 2.0	IG switch ON, ABS warning light ON
	10 - 14	IG switch ON, ABS warning light OFF
PKB (A18-14) - GND (A19-15)	Below 1.5	IG switch ON, PKB switch ON
	10 - 14	IG switch ON, PKB switch OFF
STP (A18-6) - GND (A19-2)	Below 1.5	Stop light switch OFF
	10 - 14	Stop light switch ON
D/G (A18-4) - GND (A19-2)	10 - 14	IG switch ON, ABS warning light OFF
Tc (A19-5) - GND (A19-2)	10 - 14	IG switch ON
Ts (A18-15) - GND (A19-15)	10 - 14	IG switch ON
FR + (A19-16) - FR- (A19-3)	AC generation	IG switch ON Slowly turn right front wheel
FL + (A19-9) - FL- (A19-22)	AC generation	IG switch ON Slowly turn left front wheel
RR + (A18-8) - RR- (A18-16)	AC generation	IG switch ON Slowly turn left rear wheel
RL + (A18-9) - RL- (A18-1)	AC generation	IG switch ON Slowly turn left rear wheel
GS 1 (A18-12) - GND (A19-15)	4 - 6 or 7 - 11	IG switch ON, Vehicle parked on a level surface
GS 2 (A18-3) - GND (A19-2)	4 - 6	IG switch ON, Vehicle parked on a level surface

w/ TRAC:

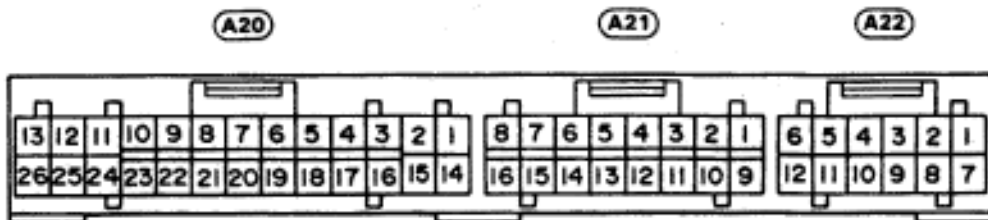

RD6498

Symbols (Terminals No.)	STD Voltage (V)	Condition
BAT (A20-7) - GND (A20-25)	10 -14	Always
IG 1 (A20-24) - GND (A20-25)	10 -14	IG switch ON
SR (A20-15) - R- (A20-12)	8.3 -14	IG switch ON, ABS warning light OFF
MR (A20-2) - R- (A20-12)	Below 1.0	IG switch ON
TSR (A20-1) - R- (A20-12)	8.3 -14	IG switch ON, TRAC and TRAC OFF indicator light OFF
TMR (A20-14) - R- (A20-12)	Below 1.0	IG switch ON
SFR (A22-1) - GND (A22-9)	10 -14	IG switch ON, ABS warning light OFF
SFL (A20-13) - GND (A20-25)	10 -14	IG switch ON, ABS warning light OFF
SRR (A20-26) - GND (A20-25)	10 -14	IG switch ON, ABS warning light OFF
SRL (A22-7) - GND (A22-9)	10 -14	IG switch ON, ABS warning light OFF
AST (A20-21) - GND (A20-25)	10 -14	IG switch ON, ABS warning light OFF
SMC (A22-2) - GND (A22-9)	10 -14	IG switch ON, TRAC and TRAC OFF indicator light OFF
SRC (A22-8) - GND (A22-9)	10 -14	IG switch ON, TRAC and TRAC OFF indicator light OFF
WA (A22-5) - GND (A22-4)	Below 2.0	IG switch ON, ABS warning light ON
	10 -14	IG switch ON, ABS warning light OFF
PKB (A22-12) - GND (A22-4)	Below 1.5	IG switch ON, PKB switch ON Fluid in M/C reservoir above MIN level.
	10 -14	IG switch ON, PKB switch OFF Fluid in M/C reservoir above MIN level.
LBL (A20-10) - GND (A20-25)	10 -14	IG switch ON Fluid in M/C reservoir above MIN level.
	Below 1.5	Stop light switch OFF
STP (A22-6) - GND (A22-4)	8 -14	Stop light switch ON
	10 -14	IG switch ON, ABS warning light OFF
D/G (A22-10) - GND (A22-9)	10 -14	IG switch ON, ABS warning light OFF

Symbols (Terminals No.)	STD Voltage (V)	Conditions
Tc (A20-23) - GND (A20-25)	10 -14	IG switch ON
Ts (A20-11) - GND (A20-25)	10 -14	IG switch ON
FR + (A20-17) - FR - (A20-4)	10 -14	IG switch ON Slowly turn right front wheel.
FL + (A20-5) - FL - (A20-18)	AC generation	IG switch ON Slowly turn left front wheel.
RR + (A21-2) - RR - (A21-10)	AC generation	IG switch ON Slowly turn right rear wheel.
RL + (A21-9) - RL - (A21-1)	AC generation	IG switch ON Slowly turn left rear wheel.
FRO (A21-13) - GND (A22-4)	Pulse generation	IG switch ON Slowly turn right front wheel.
FLO (A21-15) - GND (A22-4)	Pulse generation	IG switch ON Slowly turn left front wheel.
RRO (A21-6) - GND (A22-4)	Pulse generation	IG switch ON Slowly turn right rear wheel.
RLO (A21-4) - GND (A22-4)	Pulse generation	IG switch ON Slowly turn left rear wheel.
GS 1 (A20-8) - GND (A20-25)	4 - 6 or 7 - 11	IG switch ON, Vehicle parked on a level surface
GS 2 (A20-20) - GND (A20-25)	4 - 6	IG switch ON, Vehicle parked on a level surface
EXO (A21-12) - GND (A22-4)	10 -14	IG switch ON

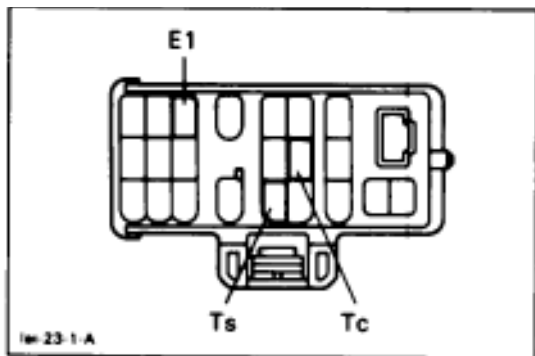

SPEED SENSOR SIGNAL CHECK

1. Turn the ignition switch OFF
2. Using SST, connect terminals Ts and E1 of DLC1.
SST 09843-18020
3. Start the engine.

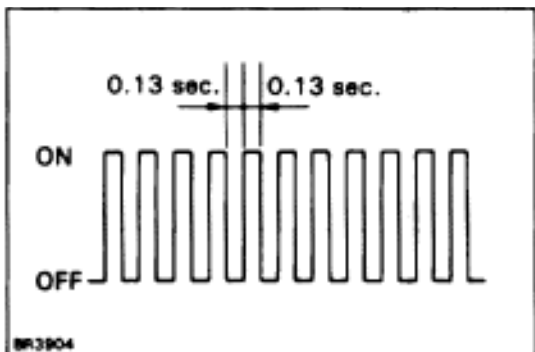

4. Check that the ABS warning light blinks.
HINT:
 - If the ABS warning light does not blink, inspect the ABS warning light circuit (See page BR-107).
 - If the ABS warning light is always on, inspect and repair the IG1 terminal of lateral acceleration sensor.
5. Drive the vehicle faster than 45 km/h (28 mph) for several seconds.
6. Stop the vehicle.
7. Using SST, connect terminals Tc and E1 of DLC1.
SST 09843-18020
8. Read the number of blinks of the ABS warning light.
HINT: See the list of diagnostic trouble codes shown on the next page.

If every sensor is normal, a normal code is output (A cycle of 0.25 sec. ON and 0.25 sec. OFF is repeated).

If 2 or more malfunctions are indicated at the same time, the lowest numbered code will be displayed first.

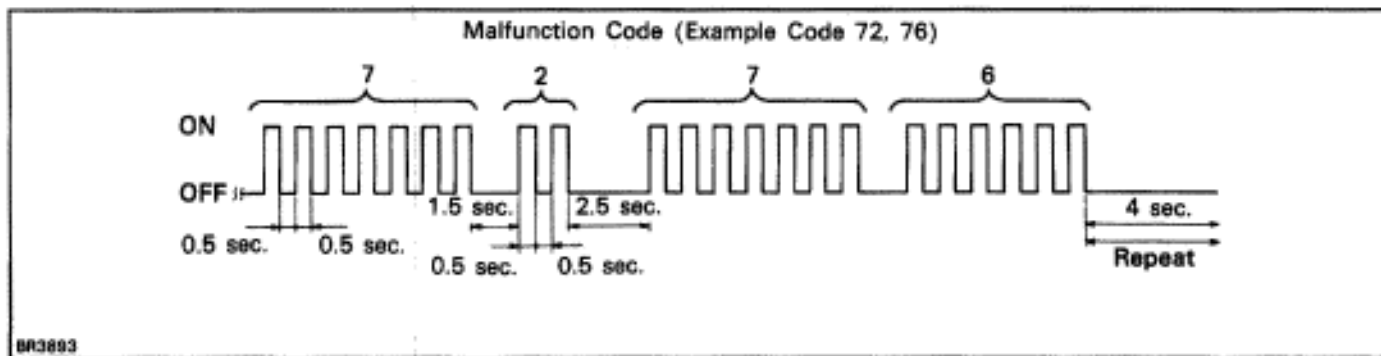

9. After doing the check, disconnect terminals Ts and E1, Tc and E1 of DLC1, and turn ignition switch OFF.

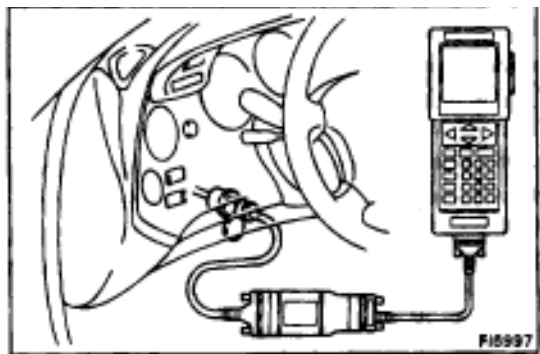

ECU DATA MONITOR USING TOYOTA HAND-HELD TESTER

1. Hook up the TOYOTA hand-held tester to the DLC2.
2. Monitor the ECU data by following the prompts on the tester screen.

HINT: TOYOTA hand-held tester has a "Snapshot" function which records the monitored data.

Please refer to the TOYOTA hand-held tester operator's manual for further details.

Diagnostic Trouble Code of Speed Sensor Check Function

Code No.	Diagnosis	Trouble Area
71	Low output voltage of right front speed sensor	Right front speed sensor Sensor installation
72	Low output voltage of left front speed sensor	Left front speed sensor Sensor installation
73	Low output voltage of right rear speed sensor	Right rear speed sensor Sensor installation
74	Low output voltage of left rear speed sensor	Left rear speed sensor Sensor installation
75	Abnormal change in output voltage of right front speed sensor	Right front speed sensor rotor
76	Abnormal change in output voltage of left front speed sensor	Left front speed sensor rotor
77	Abnormal change in output voltage of right rear speed sensor	Right rear speed sensor rotor
78	Abnormal change in output voltage of left rear speed sensor	Left rear speed sensor rotor

PROBLEM SYMPTOMS CHART

If a normal code is displayed during the diagnostic trouble code check but the problem still occurs, check the circuits for each problem symptom in the order given in the table below and proceed to the relevant troubleshooting page.

Symptoms	Inspection Circuit	See page
ABS does not operate.	<p>Only when 1. ~ 4. are all normal and the problem is still occurring, replace the ABS (& TRAC) ECU.</p> <ol style="list-style-type: none"> 1. Check the diagnostic trouble code, reconfirming that the normal code is output. 2. IG power source circuit. 3. Speed sensor circuit. 4. Check the ABS actuator with a checker. If abnormal, check the hydraulic circuit for leakage (See page BR-115). 	<p>BR-54</p> <p>BR-92</p> <p>BR-88</p> <p>BR-44</p>
ABS does not operate efficiently	<p>Only when 1. ~ 4. Are all normal and the problem is still occurring, replace the ABS (& TRAC) ECU.</p> <ol style="list-style-type: none"> 1. Check the diagnostic trouble code, reconfirming that the normal code is output. 2. Speed sensor circuit. 3. Stop light switch circuit. 4. Check the ABS actuator with a checker. If abnormal, check the hydraulic circuit for leakage (See page BR-115). 	<p>BR-54</p> <p>BR-88</p> <p>BR-105</p> <p>BR-44</p>
ABS warning light abnormal	<ol style="list-style-type: none"> 1. ABS warning light circuit. 2. ABS (& TRAC) ECU. 	BR-107
Diagnostic trouble code check cannot be performed	<p>Only when 1 and 2 are all normal and the problem is still occurring, replace the ABS (& TRAC) ECU.</p> <ol style="list-style-type: none"> 1. ABS warning light circuit. 2. Tc terminal circuit. 	<p>BR-107</p> <p>BR-112</p>
Speed sensor signal check cannot be performed	<ol style="list-style-type: none"> 1. Ts terminal circuit. 2. ABS (& TRAC) ECU. 	BR-114

CIRCUIT INSPECTION

DTC 11 12 ABS Solenoid Relay Circuit

CIRCUIT DESCRIPTION

This relay supplies power to each ABS solenoid. After the ignition switch is turned ON, if the initial check is OK, the relay goes on.

DTC No.	Diagnostic Trouble Code Detecting Condition	Trouble area
11	Conditions (1) and (2) continue for 0.2 sec. or more: (1) ABS solenoid relay terminal (SR) voltage: Battery positive voltage (2) Solenoid relay monitor terminal (AST) voltage: 0 V	ABS solenoid relay Open or short in ABS solenoid relay circuit ECU
12	Conditions (1) and (2) continue for 0.2 sec. or more: (1) ABS solenoid relay terminal (SR) voltage: 0 V (2) Solenoid relay monitor terminal (AST) voltage: Battery positive voltage	ABS solenoid relay B+ short in ABS solenoid relay circuit ECU

Fail safe function: If trouble occurs in the solenoid relay circuit, the ECU cuts off current to the solenoid relay and prohibits ABS control.

WIRING DIAGRAM

w/o TRAC

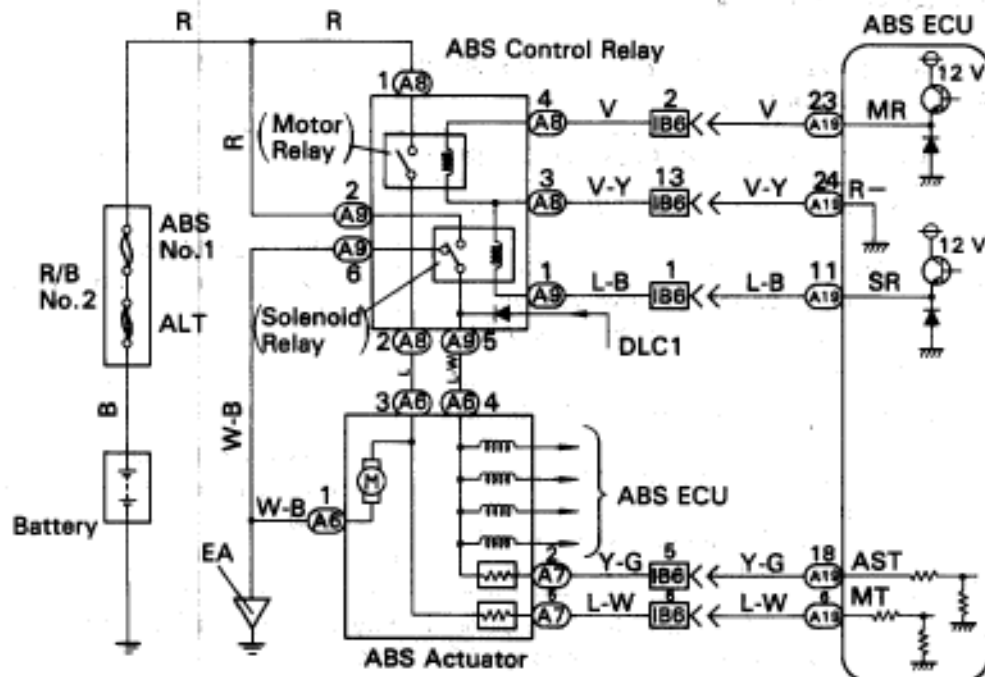

w/ TRAC

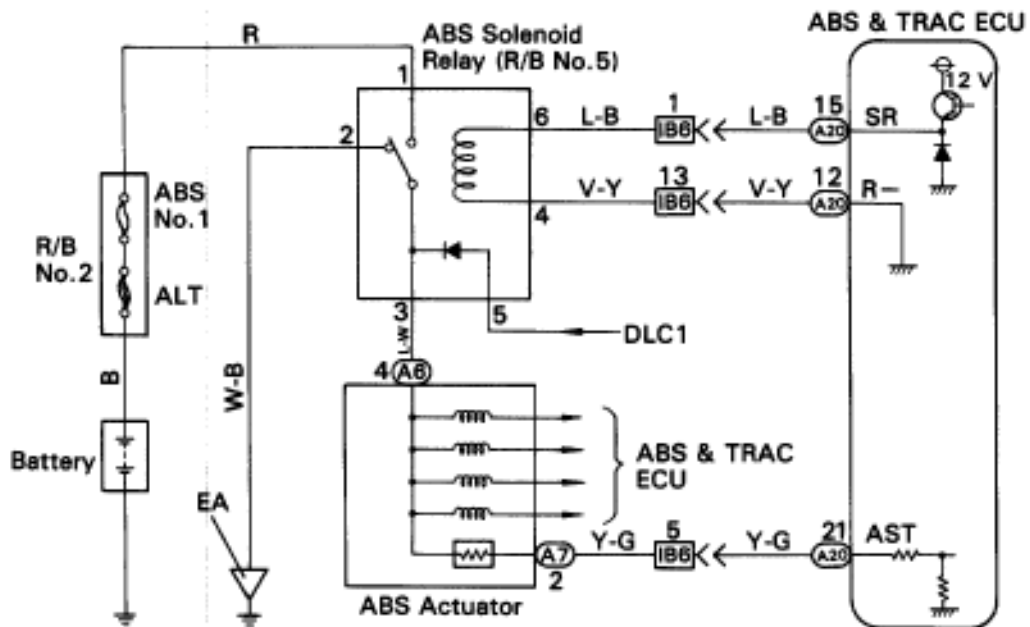

INSPECTION PROCEDURE (w/o TRAC)

1

Check voltage between terminals (A9) 2 and (A9) 6 of ABS solenoid relay connector.

LOCK

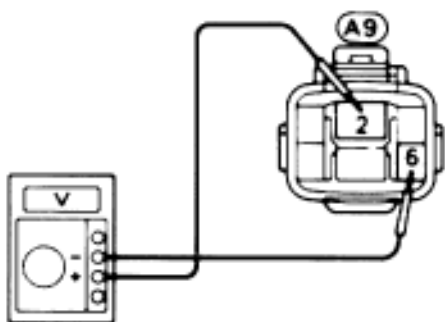
M 6653
R00892

- P** Disconnect the ABS solenoid relay connector.
- C** Measure voltage between terminals (A9) 2 and (A9) 6 of ABS solenoid relay harness side connector.
- OK** Voltage: 10 — 14 V

OK

NG Check and repair harness or connector.

2

Check continuity between terminal (A9) 5 OF ABS solenoid relay connector and terminal (A19) 18 of ABS ECU.

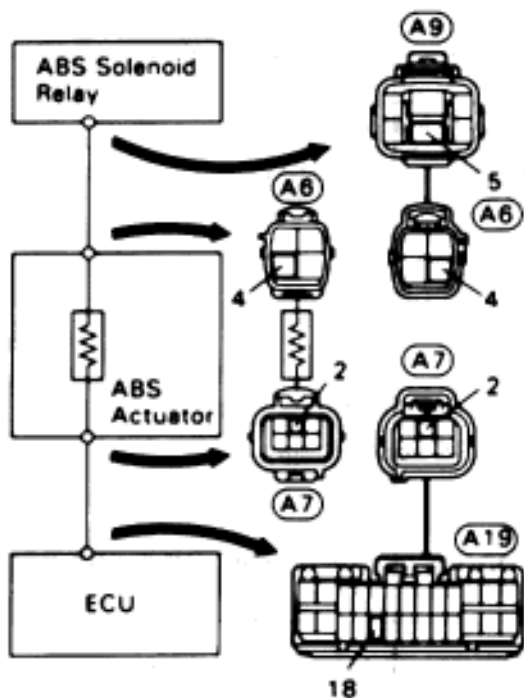

R07077

- P** Disconnect the connectors from ABS actuator.
- C** Check continuity between terminal (A9) 5 of ABS solenoid relay connector and terminal (A19) 18 of ABS ECU.
- OK** Continuity.
- Hint** There is a resistance of 4 ~ 6 Ω between terminals (A6) 4 and (A7) 2 of ABS actuator.

OK

NG Repair or replace harness or ABS actuator.

3

Check ABS solenoid relay.

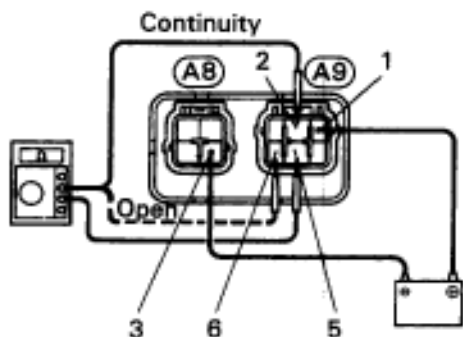
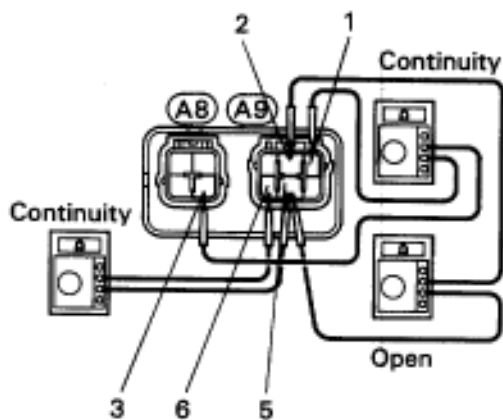

C Check continuity between each terminal of ABS solenoid relay shown below.

OK

Terminals	(A9) 1 and (A8) 3	Continuity (Reference value 80 Ω)
Terminals	(A9) 5 and (A9) 6	Continuity
Terminals	(A9) 2 and (A9) 5	Open

C

- (1) Apply battery voltage between terminals (A9) 1 and (A8) 3.
- (2) Check continuity between each terminal of ABS solenoid relay shown below.

OK

Terminals	(A9) 5 and (A9) 6	Open
Terminals	(A9) 2 and (A9) 5	Continuity

R0C889
R0C886

OK

NG

Replace ABS control relay.

4

Check for open and short in harness and connector between ABS solenoid relay and ABS ECU (See page IN-30).

OK

NG

Repair or replace harness or connector.

If the same code is still output after the diagnostic trouble code is deleted, check the contact condition of each connection.

If the connections are normal, the ECU may be defective.

INSPECTION PROCEDURE (w/ TRAC)

1

Check voltage between terminals 1 and 2 of R/B No. 5 (for ABS solenoid relay).

LOCK

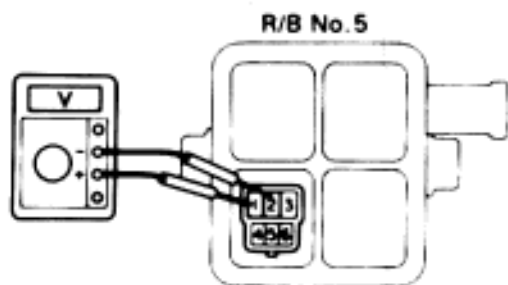
ME6653
RD7047

- P** Remove ABS solenoid relay from R/B No. 5.
- C** Measure voltage between terminals 1 and 2 of R/B No. 5 (for ABS solenoid relay).
- OK** Voltage: 10 — 14 V

OK

NG Check and repair harness or connector.

2

Check continuity between terminal 3 of R/B No.5 (for ABS solenoid relay) and terminal (A20) 21 of ABS & TRAC ECU.

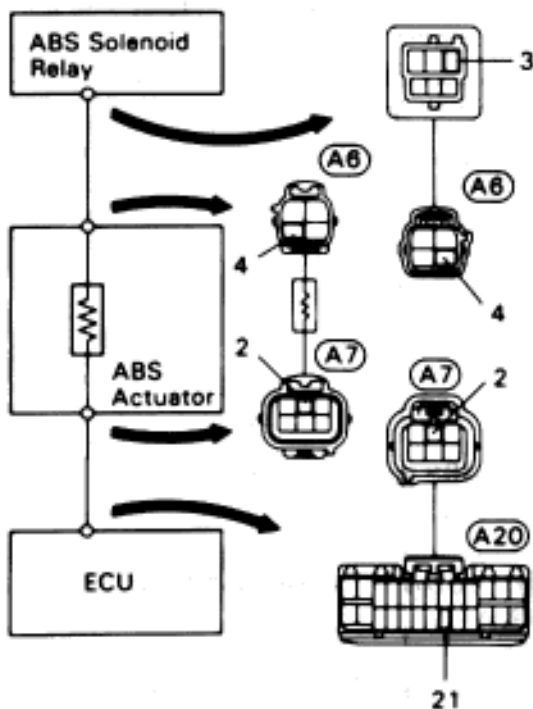

R11334

- C** Check continuity between terminal 3 of R/B No.5 (for ABS solenoid relay) and terminal (A20) 21 OF ABS & TRAC ECU.

OK Continuity

HINT: There is a resistance of 4 ~ 6 Ω between terminals (A6) 4 and (A7) 2 of ABS actuator.

OK

NG Repair or replace harness or ABS connector.

Check ABS solenoid relay.

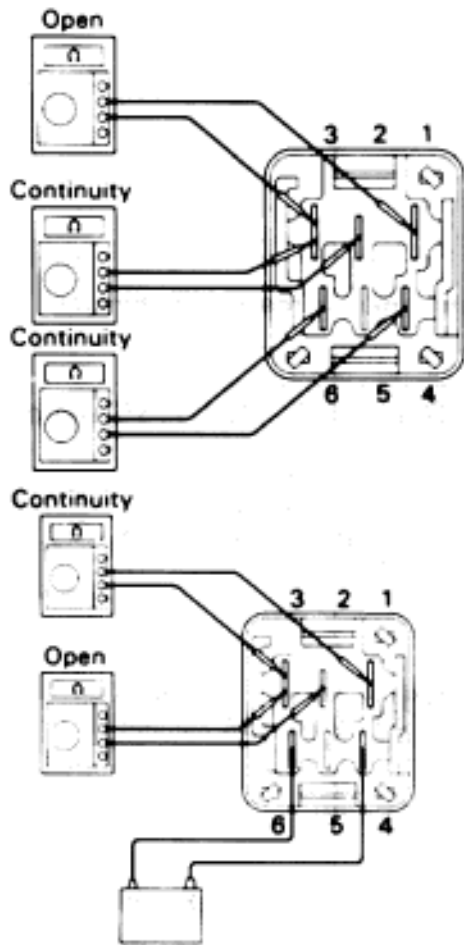
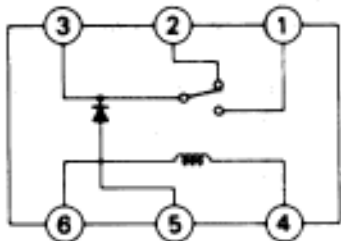

BRS403
BRS404
BRS405

P Remove solenoid relay from R/B No. 5.

C Check continuity between each terminal of ABS solenoid relay shown below.

OK

Terminals 4 and 6	Continuity (Reference value 80)
Terminals 2 and 3	Continuity
Terminals 1 and 3	Open

C 1. Apply battery voltage between terminals 4 and 6.
2. Check continuity between each terminal of ABS solenoid relay shown below.

OK

Terminals 2 and 3	Open
Terminals 1 and 3	Continuity

OK

NG

Replace ABS solenoid relay.

Check for open and short in harness and connector between ABS solenoid relay and ABS & TRAC ECU (See page [IN-30](#)).

OK

NG

Repair or replace harness or connector.

If the same code is still output after the diagnostic trouble code is deleted, check the contact condition of each connection.

If the connections are normal, the ECU may be defective.

DTC 13 14 ABS Motor Relay Circuit

CIRCUIT DESCRIPTION

The ABS motor relay supplies power to the ABS pump motor. While the ABS is activated, the ECU switches the motor relay ON and operates the ABS pump motor.

DTC No.	Diagnostic Trouble Code Detecting Condition	Trouble area
13	Conditions (1) and (2) continue for 0.2 sec. or more: (1) ABS motor relay terminal (MR) voltage: Battery positive voltage (2) Motor relay monitor terminal (MT) voltage: 0 V	ABS motor relay Open or short in ABS motor relay circuit ECU
14	Conditions (1) and (2) continue for 4 sec. or more: (1) ABS motor relay terminal (MR) voltage: 0 V (2) Motor relay monitor terminal (MT) voltage: Battery positive voltage	ABS motor relay B+ short in ABS motor relay circuit ECU

Fail safe function: If trouble occurs in the motor relay circuit, the ECU cuts off the current to the solenoid relay and prohibits ABS control.

WIRING DIAGRAM

w/o TRAC

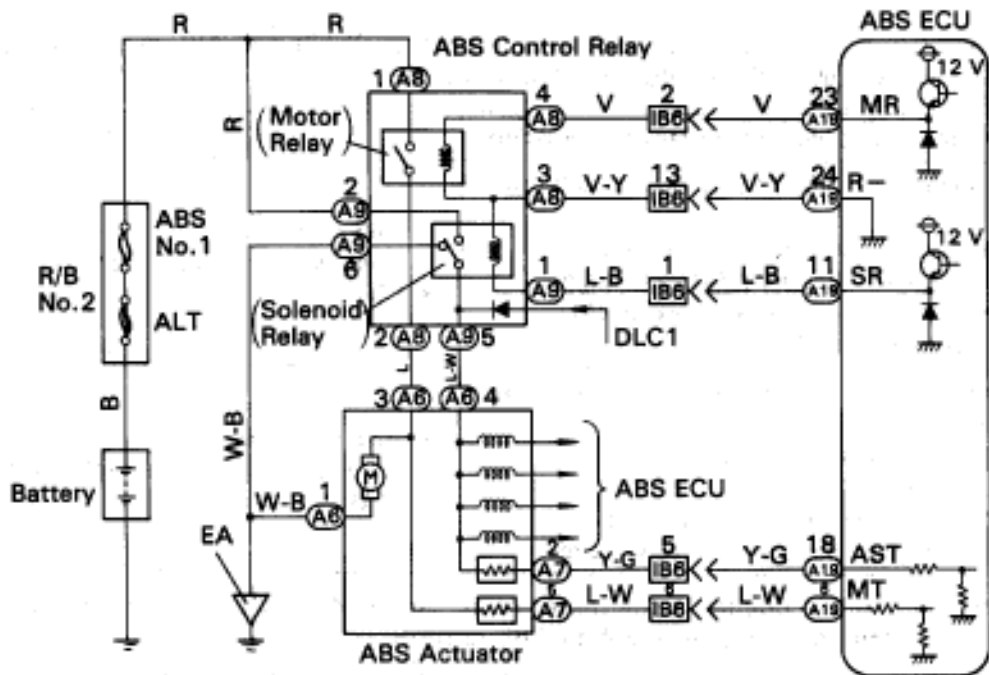

w/ TRAC

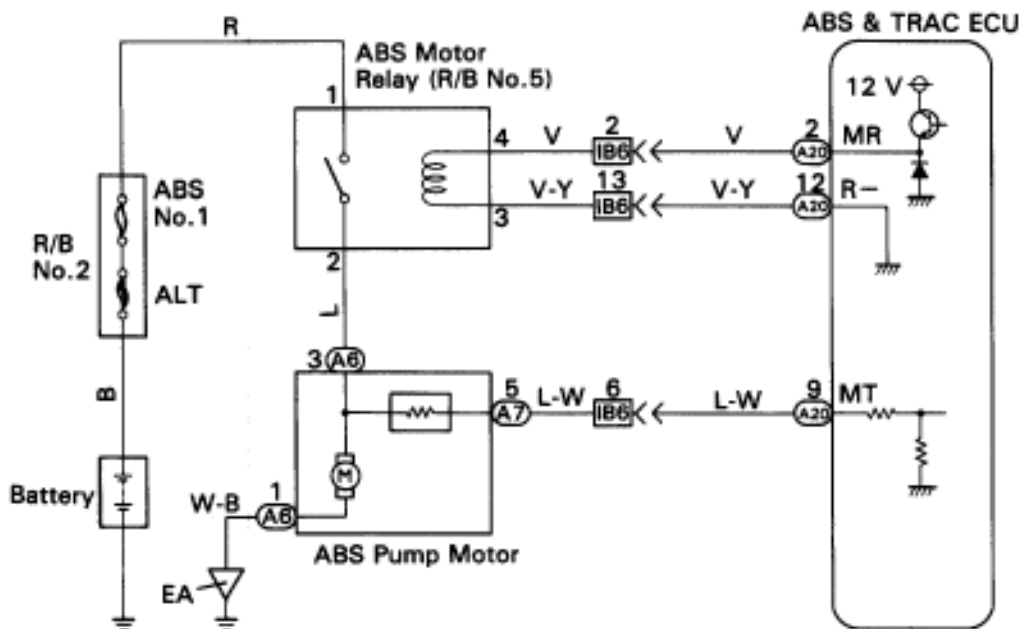

INSPECTION PROCEDURE (w/o TRAC)

1 Check voltage between terminal (A8) 1 of ABS motor relay connector and body ground.

LOCK

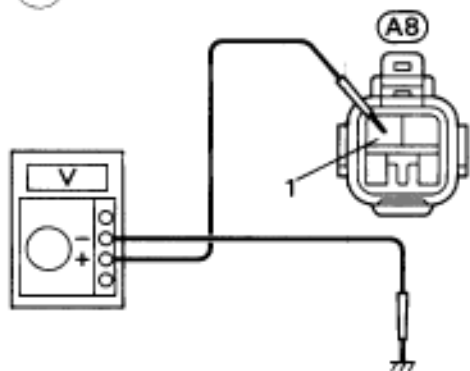
BE6653
R00890

P Disconnect the ABS motor relay connector.

C Measure voltage between terminal (A8) 1 of ABS motor relay connector and body ground.

OK Voltage: 10 — 14 V

OK

NG

Check and repair harness or connector.

2 Check continuity between terminal (A8) 2 of ABS motor relay connector and terminal (A19) 6 of ABS ECU.

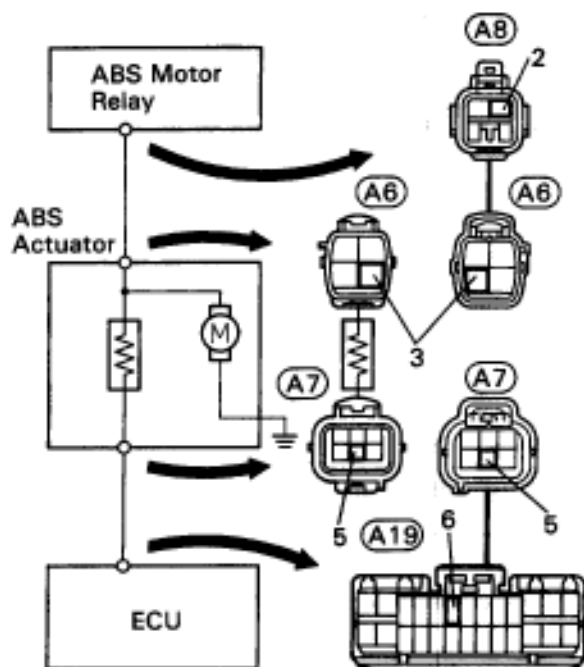

R07078

P Disconnect the connectors from the ABS actuator.

C Check continuity between terminal (A8) 2 of ABS motor relay connector and terminal (A19) 6 of ABS ECU.

OK Continuity

Hint There is a resistance of 4 ~ 6 Ω between terminals (A6) 3 and (A7) 5 of ABS actuator.

OK

NG

Repair or replace harness or ABS actuator.

3 Check ABS motor relay.

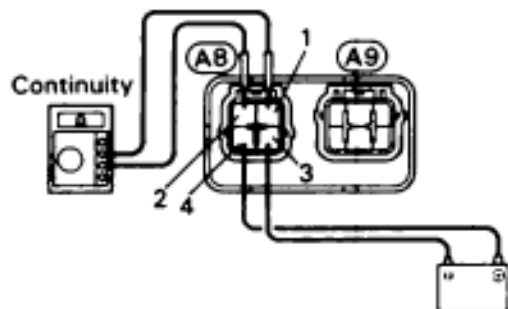
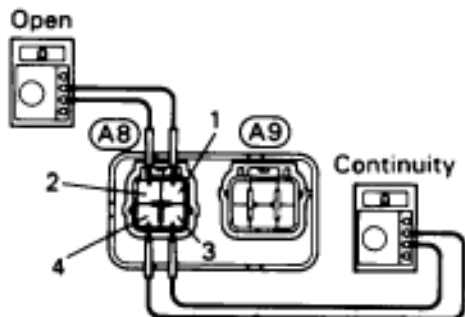
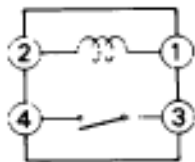

BE1840
RC0894
RC0893

OK

C Check continuity between each terminal of ABS motor relay shown below.

OK

Terminals (A8) 3 and (A8) 4	Continuity (Reference value 62)
Terminals (A8) 1 and (A8) 2	Open

C (1) Apply battery voltage between terminals (A8) 3 and (A8) 4.
(2) Check continuity between each terminal of ABS motor relay shown below.

OK

Terminals (A8) 1 and (A8) 2	Continuity
-----------------------------	------------

NG

Replace ABS control relay.

4

Check for open and short in harness and connector between ABS motor relay and ABS ECU (See page [IN-30](#)).

OK

NG

Repair or replace harness or connector.

If the same code is still output after the diagnostic trouble code is deleted, check the contact condition of each connection.
If the connections are normal, the ECU may be defective.

INSPECTION PROCEDURE (w/ TRAC)

1 Check voltage between terminal 1 of R/B No. 5 (for ABS motor relay) and body ground.

LOCK

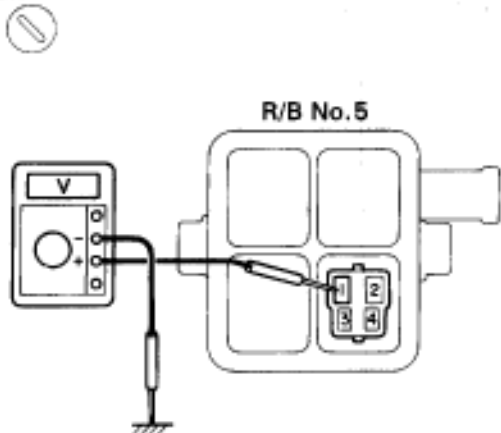
BE8853
R07048

- P** Remove ABS motor relay from R/B No. 5.
- C** Measure voltage between terminal 1 of R/B No. 5 (for ABS motor relay) and body ground.
- OK** Voltage: 10 — 14 V

OK

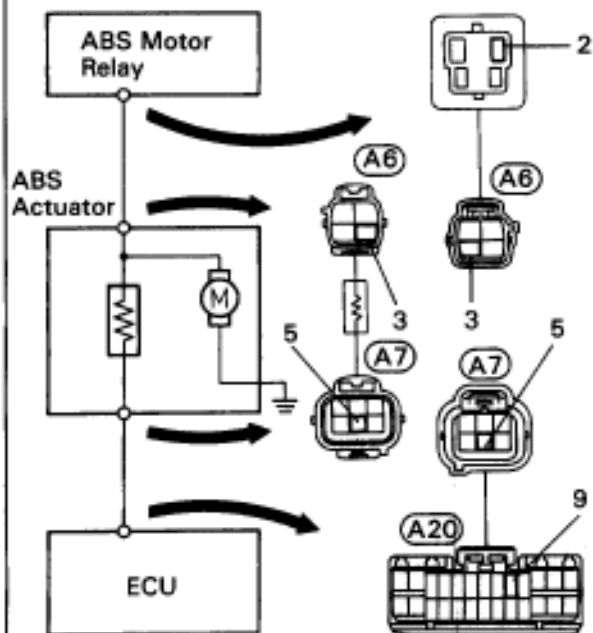
NG Check and repair harness or connector.**2** Check continuity between terminal 2 of R/B No.5 (for ABS motor relay) and terminal (A20) 9 of ABS & TRAC ECU.

R11336

- C** Check continuity between terminal 2 of R/B No.5 (for ABS motor relay) and terminal (A20) 9 of ABS & TRAC ECU.

OK Continuity

HINT: There is a resistance of 4 ~ 6 Ω between terminals (A6) 3 and (A7) 5 of ABS actuator.

OK

NG Repair or replace harness or ABS actuator.

3 Check ABS motor relay.

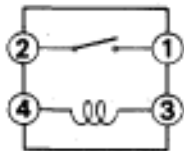

Open

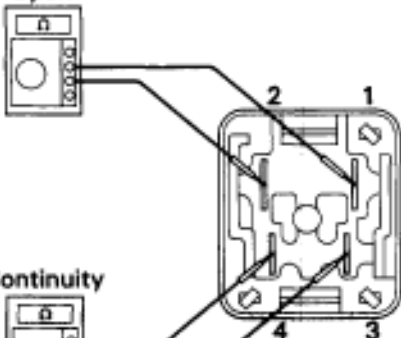

Continuity

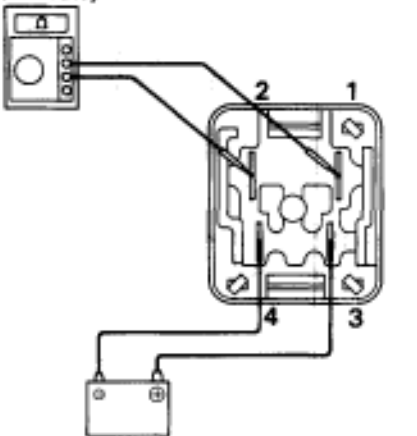

Continuity

BE184D
BR540E
BR540G

P Remove motor relay from R/B No. 5.

C Check continuity between each pair of terminals of motor relay shown below.

OK

Terminals 3 and 4	Continuity (Reference value 62 Ω)
Terminals 1 and 2	Open

C 1. Apply battery voltage between terminals 3 and 4.
2. Check continuity between each terminal shown below.

OK

Terminals 1 and 2	Continuity

OK

NG Replace ABS motor relay.

4 Check for open and short in harness and connector between ABS motor relay and ABS TRAC ECU (See page IN-30).

OK

NG Repair or replace harness or connector.

If the same code is still output after the diagnostic trouble code is deleted, check the contact condition of each connection.
If the connections are normal, the ECU may be defective.

DTC 15 16 TRAC Solenoid Relay Circuit

CIRCUIT DESCRIPTION

This relay circuit supplies power to each traction actuator solenoid.

When the ignition switch is turned ON, the relay goes on.

DTC No.	Diagnostic Trouble Code Detecting Condition	Trouble area
15	Conditions (1) through (3) continue for 0.2 sec. or more: (1) TRAC solenoid relay terminal (TSR) voltage: Battery positive voltage (2) All TRAC actuator solenoids: OFF (3) All TRAC actuator solenoid monitor voltages (in ECU): 0 V	TRAC solenoid relay Open or short in TRAC solenoid relay circuit ECU
16	Conditions (1) through (3) continue for 0.2 sec. or more: (1) TRAC solenoid relay terminal (TSR) voltage: 0 V (2) All TRAC actuator solenoids: OFF (3) TRAC actuator solenoid monitor voltage (in ECU): Battery positive voltage	TRAC solenoid relay B+ short in TRAC solenoid relay circuit ECU

Fail safe function: If trouble occurs in this relay circuit, the ECU cuts off current to the ABS and TRAC solenoid relays and prohibits ABS and TRAC control.

WIRING DIAGRAM

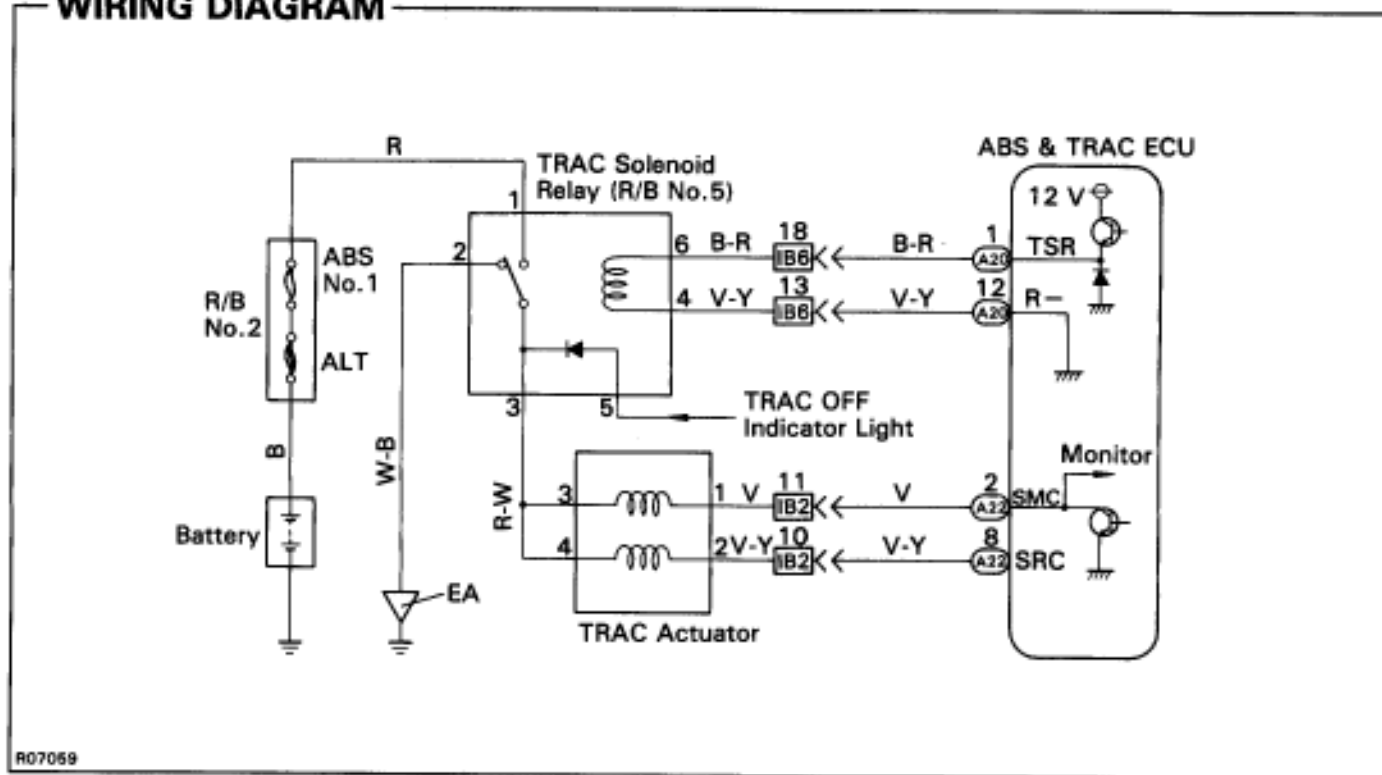

INSPECTION PROCEDURE

1

Check voltage between terminals 1 and 2 of R/B No. 5 (for TRAC solenoid relay).

LOCK

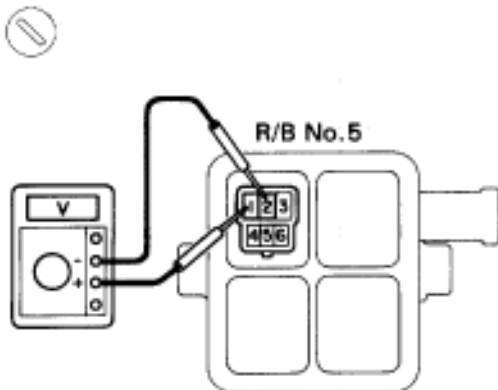
BE6653
R07049

- P** Remove TRAC solenoid relay from R/B No. 5.
- C** Measure voltage between terminals 1 and 2 of R/B No. 5 (for TRAC Solenoid relay).
- OK** Voltage 10 — 14 V

OK

NG Repair or replace harness or connector.

2

Check continuity between terminal 3 of R/B No.5 (for TRAC solenoid relay) and terminals (A22) 2 and (A22) 8 of ABS & TRAC ECU.

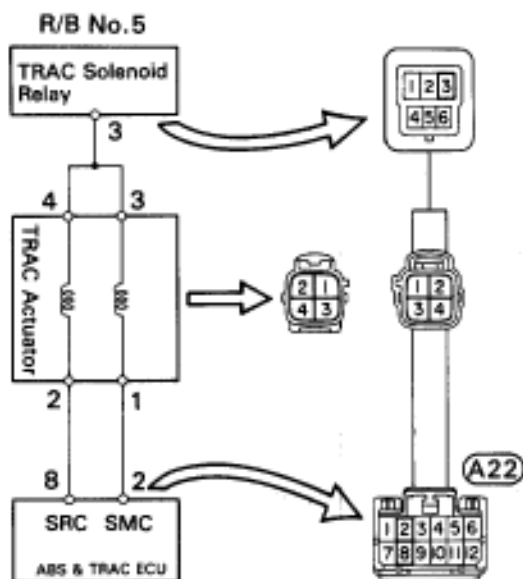

R07078

- C** Check continuity between terminal 3 of R/B No.5 (for TRAC solenoid relay) and terminals (A22) 2 and (A22) 8 of ABS & TRAC ECU.

OK Continuity

HINT: Resistance of the TRAC actuator solenoid is 2

OK

NG Repair or replace harness or TRAC actuator.

3

Check TRAC solenoid relay.

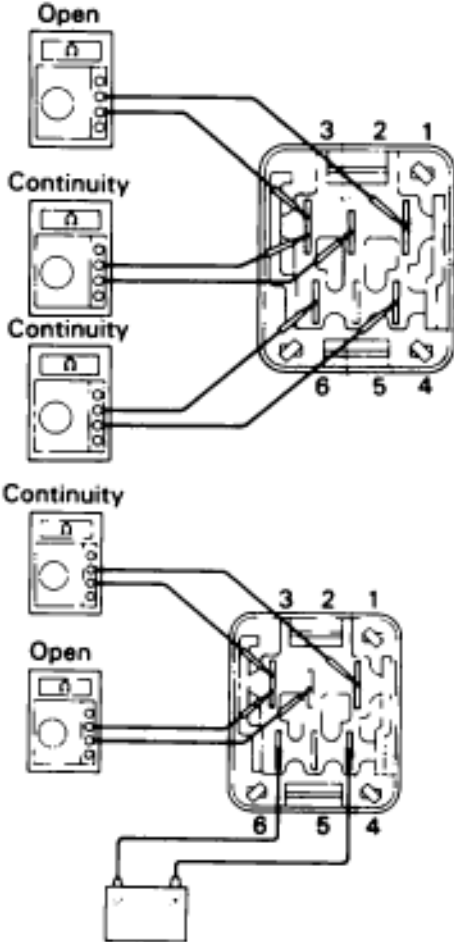
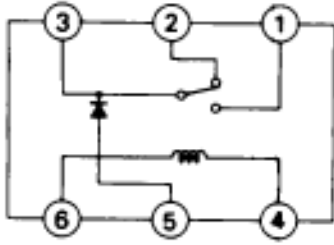

BRS403
BRS404
BRS405

P Remove TRAC solenoid relay from R/B No. 5.

C Check continuity between each terminal of TRAC solenoid relay shown below.

OK

Terminals 4 and 6	Continuity (Reference value 80)
Terminals 2 and 3	Continuity
Terminals 1 and 3	Open

C 1. Apply battery voltage between terminals 4 and 6.
2. Check continuity between terminal shown below.

OK

Terminals 2 and 3	Open
Terminals 1 and 3	Continuity

OK

NG Replace TRAC solenoid relay.

4

Check for open and short in harness and connector between TRAC solenoid relay and ABS & TRAC ECU (See page IN-30).

OK

NG Repair or replace harness or connector.

If the same code is still output after the diagnostic trouble code is deleted, check the contact condition of each connection.
If the connections are normal, the ECU may be defective.

DTC 17 18 TRAC Motor Relay Circuit

CIRCUIT DESCRIPTION

This relay circuit supplies power to the TRAC pump motor. While the TRAC is activated, the ECU switches the motor relay ON and operates the TRAC pump motor.

DTC No.	Diagnostic Trouble Code Detecting Condition	Trouble area
17	Conditions (1) and (2) continue for 0.2 sec. or more: (1) TRAC motor relay terminal (TMR) voltage: Battery positive voltage (2) Voltage of ABS & TRAC ECU terminal MTT: 0 V	TRAC motor relay Open or short in TRAC motor relay circuit ECU
18	Conditions (1) and (2) continue for 2 sec. or more: (1) TRAC motor relay terminal (TMR) voltage: 0 V (2) Voltage of ABS & TRAC ECU terminal MTT: Battery positive voltage	TRAC motor relay B+ short in TRAC motor relay circuit ECU

Fail safe function: If trouble occurs in this relay circuit, the ECU cuts off current to the TRAC solenoid relay and prohibits TRAC control.

WIRING DIAGRAM

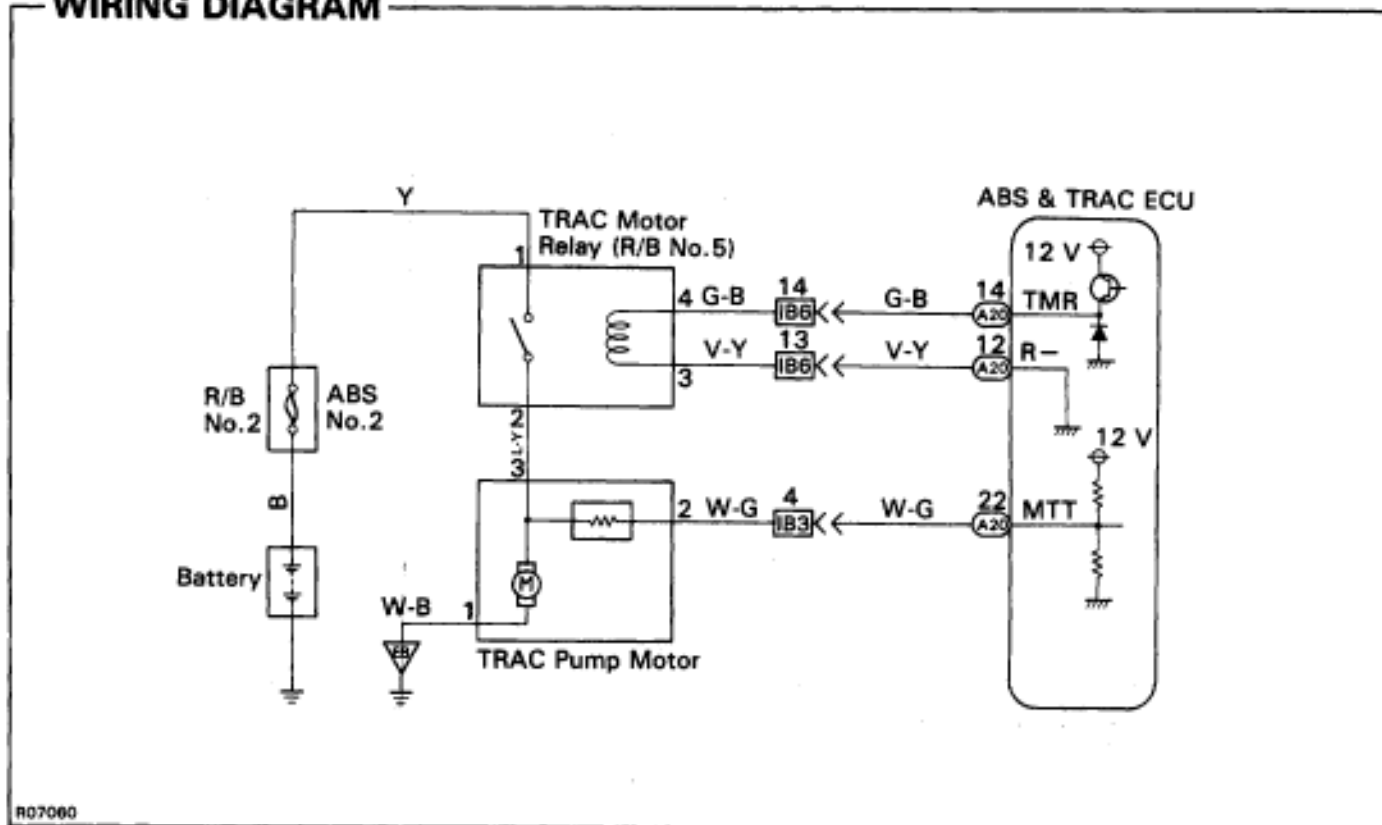

INSPECTION PROCEDURE

Check voltage between terminal 1 of R/B No. 5 (for TRAC motor relay) and body ground.

LOCK

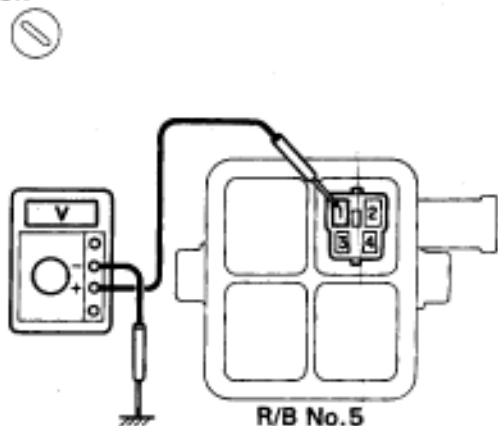
BE8853
R07050

- P** Remove TRAC motor relay from R/B No. 5.
- C** Measure voltage between terminal 1 of R/B No. 5 (for TRAC motor relay) and body ground.
- OK** Voltage: 10 — 14 V.

OK

NG Check and repair harness or connector.

Check continuity between terminal 2 of R/B No. 5 (for TRAC motor relay) and terminal 2 of TRAC pump motor.

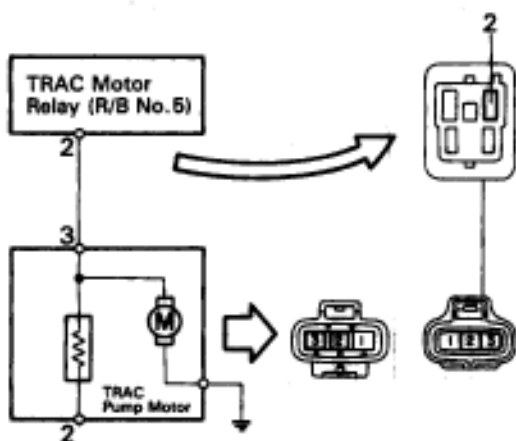

R07080

- C** Check continuity between terminal 2 of R/B No. 5 (for TRAC motor relay) and terminal 2 of TRAC pump motor.

OK Continuity.

HINT: There is a resistance of 4 — 6 Ω between terminals 2 and 3 of TRAC pump motor.

OK

NG Repair or replace harness or TRAC pump motor.

3 Check TRAC motor relay.

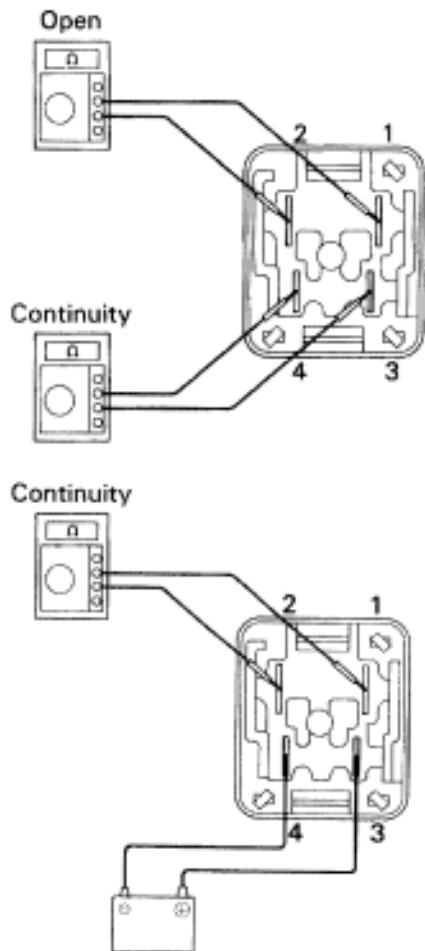
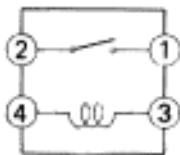

BE1840
BR5408
BR5409

P Remove TRAC solenoid relay from R/B No. 5.

C Check continuity between each terminal of TRAC solenoid relay shown below.

OK

Terminals 3 and 4	Continuity (Reference value 62)
Terminals 1 and 2	Open

C

1. Apply battery voltage between terminals 3 and 4.
2. Check continuity between terminal shown below.

OK

Terminals 1 and 2	Continuity
-------------------	------------

OK

NG

Replace TRAC solenoid relay.

4 Check for open and short in harness and connector between TRAC motor relay and ABS & TRAC ECU (See page [IN-30](#)).

OK

NG

Repair or replace harness or connector.

If the same code is still output after the diagnostic trouble code is deleted, check the contact condition of each connection.
If the connections are normal, the ECU may be defective.

DTC 21 22 23 24 ABS Actuator Solenoid Circuit

CIRCUIT DESCRIPTION

This solenoid goes on when signals are received from the ECU and controls the fluid pressure acting on the brake cylinders, thus controlling the braking force.

DTC No.	Diagnostic Trouble Code Detecting Condition	Trouble area
21	Conditions (1) through (3) continue for 0.05 sec. or more: (1) ABS solenoid relay terminal (SR) voltage: Battery positive voltage (2) Voltage of ABS (& TRAC) ECU terminal AST: Battery positive voltage (3) When power transistor of ECU is ON, voltage of terminal SFR is 0 V or battery positive voltage.	ABS actuator Open or short in SFR circuit. ECU
22	Conditions (1) through (3) continue for 0.05 sec. or more: (1) ABS solenoid relay terminal (SR) voltage: Battery positive voltage (2) Voltage of ABS (& TRAC) ECU terminal AST: Battery positive voltage (3) When power transistor of ECU is ON, voltage of terminal SFL is 0 V or battery positive voltage.	ABS actuator Open or short in SFL circuit. ECU
23	Conditions (1) through (3) continue for 0.05 sec. or more: (1) ABS solenoid relay terminal (SR) voltage: Battery positive voltage (2) Voltage of ABS (& TRAC) ECU terminal AST: Battery positive voltage (3) When power transistor of ECU is ON, voltage of terminal SRR is 0 V or battery positive voltage.	ABS actuator Open or short in SRR circuit. ECU
24	Conditions (1) through (3) continue for 0.05 sec. or more: (1) ABS solenoid relay terminal (SR) voltage: Battery positive voltage (2) Voltage of ABS (& TRAC) ECU terminal AST: Battery positive voltage (3) When power transistor of ECU is ON, voltage of terminal SRL is 0 V or battery positive voltage.	ABS actuator Open or short in SRL circuit. ECU

Fail safe function: If trouble occurs in the actuator solenoid circuit, the ECU cuts off current to the solenoid relay and prohibits ABS control.

WIRING DIAGRAM

w/o TRAC

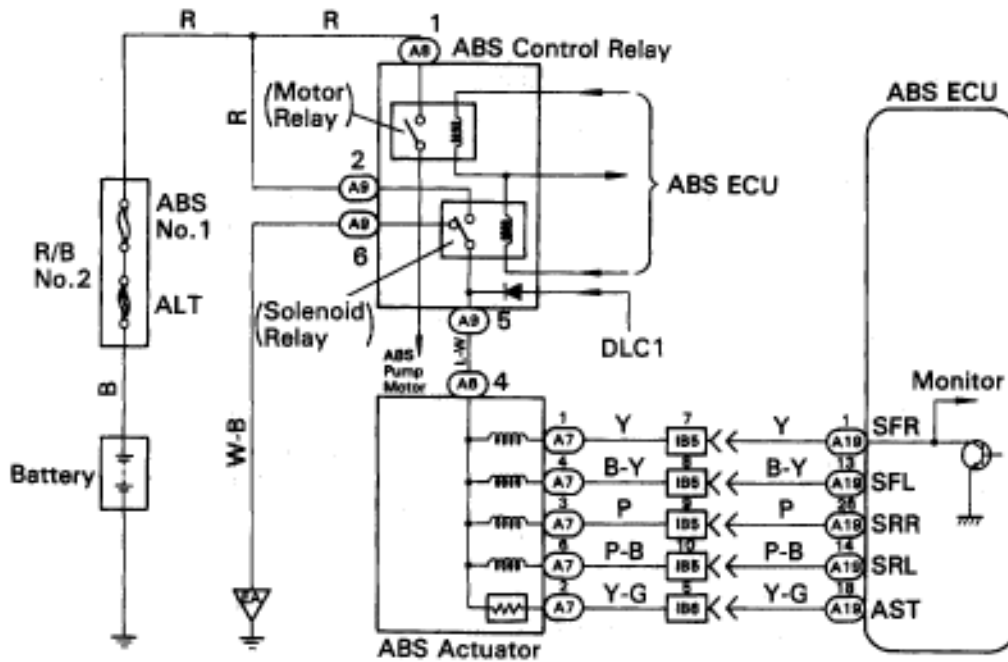

w/ TRAC

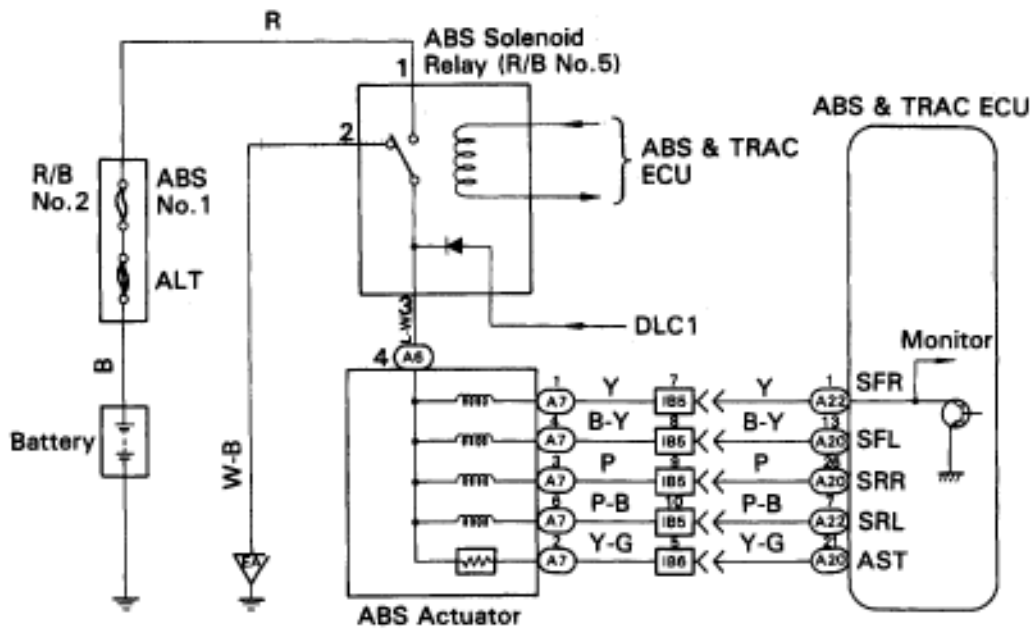

1 Check ABS actuator solenoid.

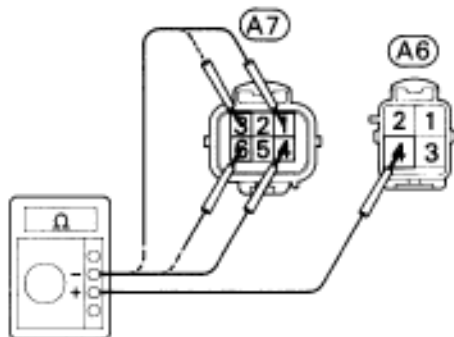

R06047

C Check continuity between terminal (A6) 4 and (A7) 1, 3, 4, 6 of the ABS actuator connector.

OK Continuity

HINT: Resistance of each solenoid coil is 1.1 .

OK

NG

Replace ABS actuator.

2

Check for open and short in harness and connector between ABS (& TRAC) ECU and actuator (See page [IN-30](#)).

OK

NG

Repair or replace harness or connector.

If the same code is still output after the diagnostic trouble code is deleted, check the contact condition of each connection.
If the connections are normal, the ECU may be defective.

INSPECTION PROCEDURE

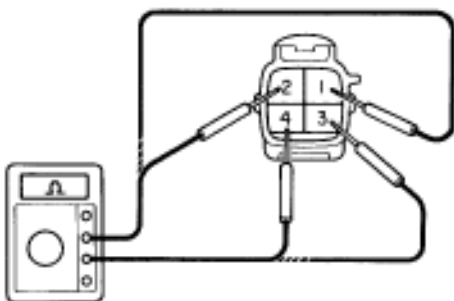
1 Check TRAC actuator solenoid.

R07085

P Disconnect TRAC actuator connector.**C** Check continuity between each terminal of TRAC solenoid relay shown below.**OK**

Terminals 1 and 3	Continuity (Reference value 2 Ω)
Terminals 2 and 4	
Terminals 1 and 2	Open

OK

NG Replace TRAC actuator.**2** Check for open and short in harness and connector between solenoid relay and ECU (See page [IN-30](#)).

OK

NG Repair or replace harness or connector.**3** Check for short in harness and connector between SMC and SRC terminals with TRAC actuator and ECU connectors are disconnected.

OK

NG Repair or replace harness or connector.

If the same code is still output after the diagnostic trouble code is deleted, check the contact condition of each connection.
If the connections are normal, the ECU may be defective.

DTC 31 32 33 34 35 36 Speed Sensor Circuit

CIRCUIT DESCRIPTION

The speed sensor detects the wheel speed and sends the appropriate signals to the ECU. These signals are used to control both the ABS and TRAC control systems. The front and rear rotors each have 48 serrations. When the rotors rotate, the magnetic field emitted by the permanent magnet in the speed sensor generates an AC voltage. Since the frequency of this AC voltage changes in the direct proportion to the speed of the rotor, the frequency is used by the ECU to detect the speed of each wheel.

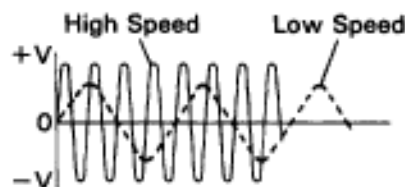
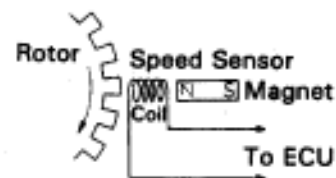

BR3583
BR3582

DTC No.	Diagnostic Trouble Code Detecting Condition	Trouble area
31, 32 33, 34	Detection of any of conditions (1) through (3): (1) At vehicle speed of 10 km/h (6 mph) or more, pulses are not input for 5 sec. (2) Momentary interruption of the vehicle speed sensor signal occurs at least 7 times in the time between switching the ignition switch ON and switching it OFF. (3) Abnormal fluctuation of speed sensor signals with the vehicle speed 20 km/h (12 mph) or more.	Right front, left front, right rear and left rear speed sensor. Open or short in each speed sensor circuit. ECU
35	Speed sensor signal is not input for about 1 sec. while the left front and right rear speed sensor signals are being checked with the IG switch ON.	Open in left front, right rear speed sensor circuit. ECU
36	Speed sensor signal is not input for about 1 sec. while the right front and left rear speed sensor signals are being checked with the IG switch ON.	Open in right front, left rear speed sensor circuit. ECU

HINT: DTC No.31 is for the right front speed sensor.
DTC No. 32 is for the left front speed sensor.
DTC No.33 is for the right rear speed sensor.
DTC No.34 is for the left rear speed sensor.

Fail safe function: If trouble occurs in the speed sensor circuit, the ECU cuts off current to the ABS solenoid relay and prohibits ABS control.

WIRING DIAGRAM

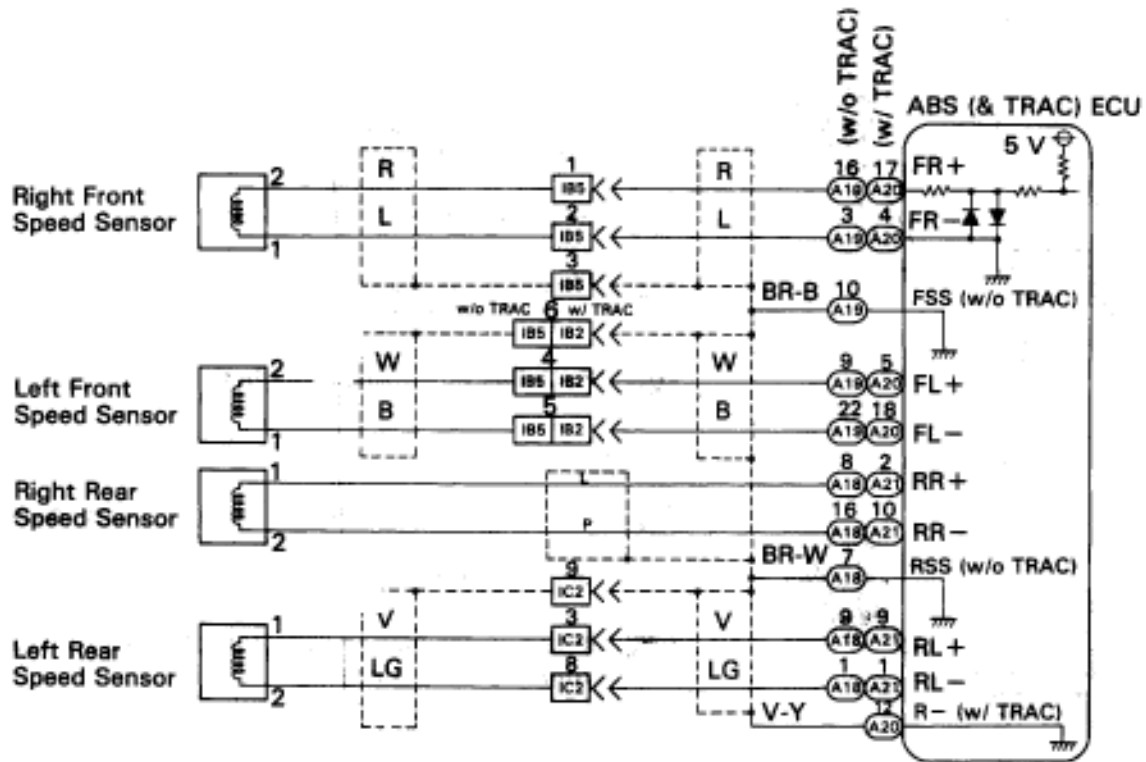

INSPECTION PROCEDURE

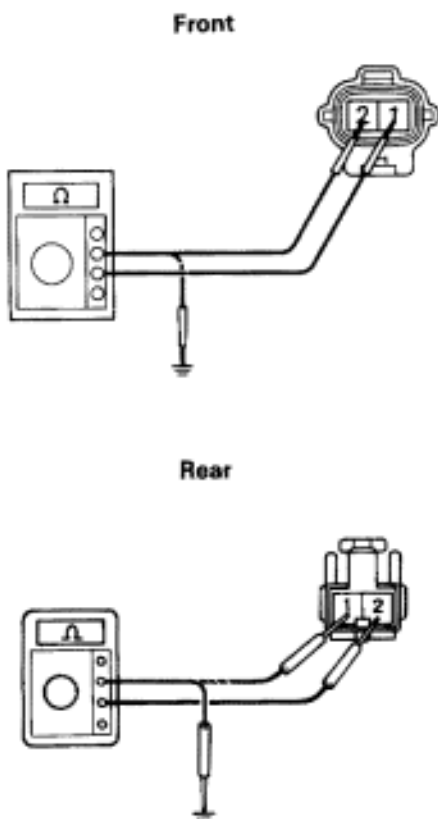
1**Check speed sensor.**BR5425
R07086**Front**

- P** 1. Remove front fender splash shield.
2. Disconnect speed sensor connector.
- C** Measure resistance between terminals 1 and 2 of speed sensor connector.
- OK** Resistance : 0.7 — 1.7 k Ω
- C** Measure resistance between terminals 1 and 2 of speed sensor connector and body ground.
- OK** Resistance : 1 M Ω or higher

Rear

- P** 1. Remove rear set cushion, seat back and quarter trim panel.
2. Disconnect speed sensor connector.
- C** Measure resistance between terminals 1 and 2 of speed sensor connector.
- OK** Resistance : 0.7 — 1.7 k Ω
- C** Measure resistance between terminals 1 and 2 of speed sensor connector and body ground.
- OK** Resistance : 1 M Ω or higher

OK**NG**

Replace speed sensor.

NOTICE: Check the speed sensor signal last (See page BR-62).

2**Check for open and short in harness and connector between each speed sensor and ECU (See page IN-30).****OK****NG**

Repair or replace harness or connector.

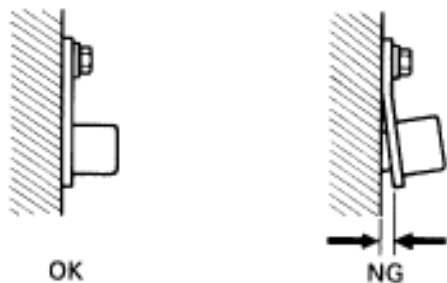
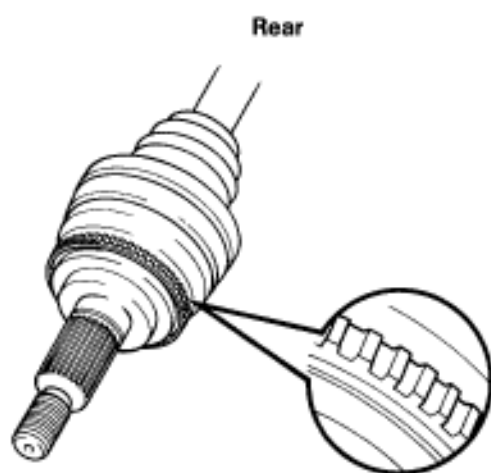
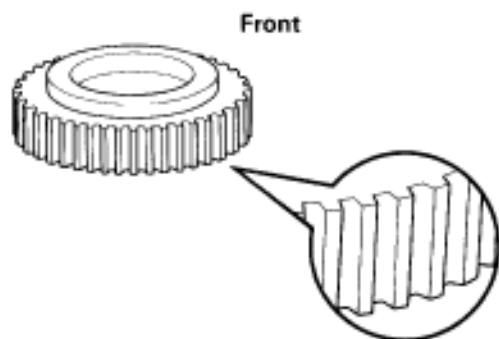
3**Check sensor rotor and sensor installation.****Front**

- P** Remove front speed sensor rotor (See page [SA-15](#)).
- C** Check sensor rotor serrations.
- OK** No scratches or missing teeth.
- C** Check the front speed sensor installation.
- OK** The installation bolt is tightened properly.

Rear

- P** Remove the drive shaft (See page [BR-45](#)).
- C** Check sensor rotor serrations.
- OK** No scratches or missing teeth.
- C** Check the rear speed sensor installation.
- OK** The installation bolt is tightened properly and there is no clearance between the sensor and rear axle carrier.

BR3719
BR3720
BR3795**OK****NG**

Replace speed sensor or rotor.

NOTICE: Check the speed sensor signal last (See page [BR-62](#)).

Check and replace ABS (& TRAC) ECU.

DTC 41 IG Power Source Circuit

CIRCUIT DESCRIPTION

This is the power source for the ECU, hence the CPU and the actuators.

DTC No.	Diagnostic Trouble Code Detecting Condition'	Trouble area
41	When either of the following (1) or (2) is detected: (1) Voltage at ECU terminal IG1 is less than 9.5 V for more than 10 sec. while vehicle speed is 3 km/h (1.9 mph) or more. (2) Voltage at ECU terminal IG1 is more than 17 V for more than 1.2 sec.	Battery IC regulator Open or short in power source circuit ECU

Fail safe function: If trouble occurs in the power source circuit, the ECU cuts off current to the ABS solenoid relay and prohibits ABS control.

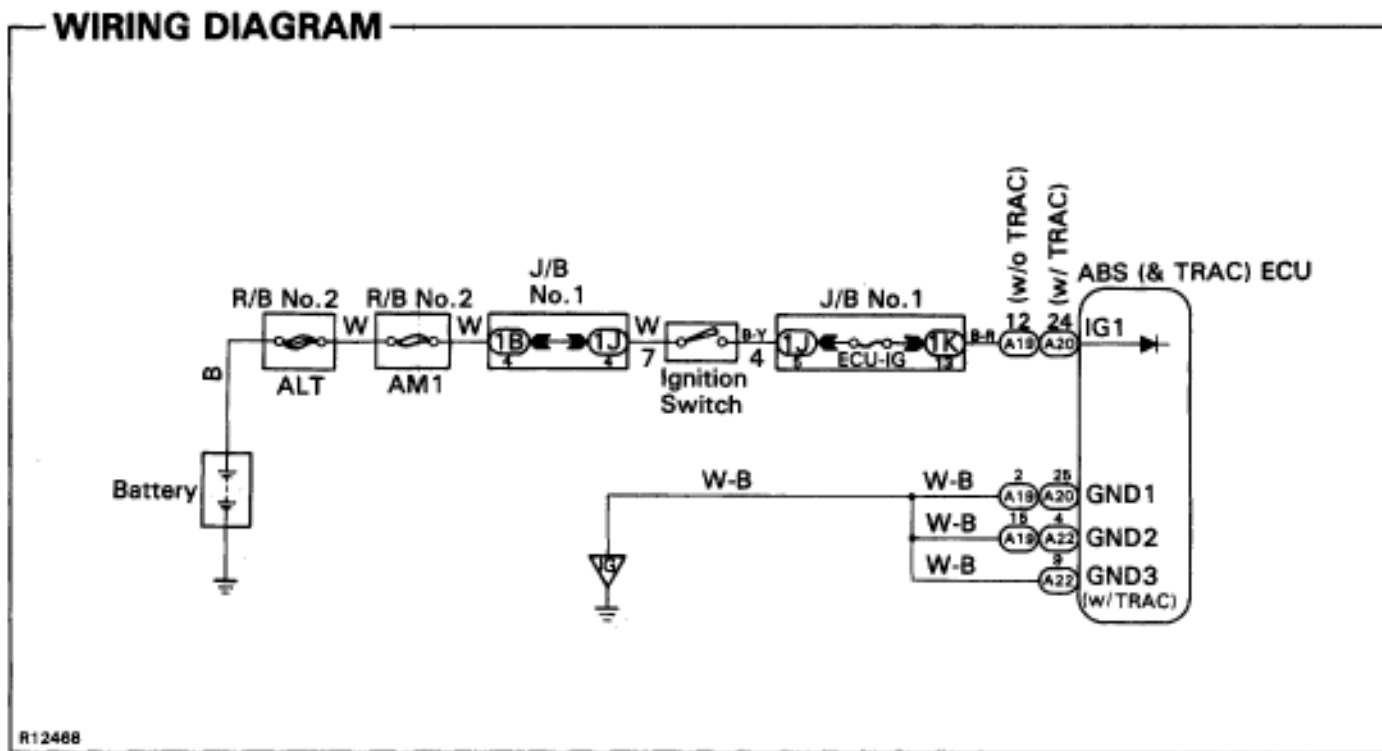

INSPECTION PROCEDURE.

1 Check battery positive voltage.

OK Voltage: 10 — 14 V

OK

NG Check and repair the charging system.

2 Check voltage between terminals IG1 and GND of ABS (& TRAC) ECU connector.

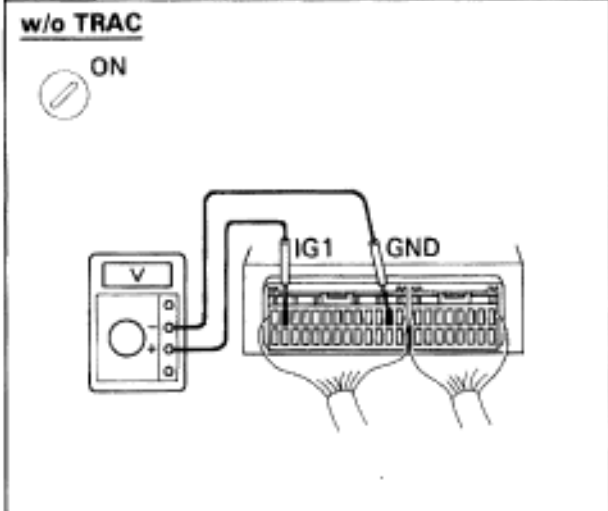

BE0053
R06982

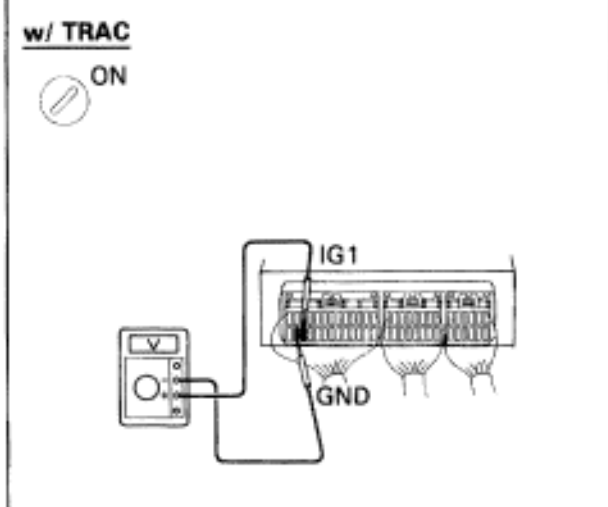

BE0053
R05927

P Remove ABS (& TRAC) ECU with connectors still connected.

C 1. Turn ignition switch ON.
2. Measure voltage between terminals IG1 and GND of ABS (& TRAC) ECU connector.

OK Voltage: 10 — 14 V

NG

OK Check and replace ABS (& TRAC) ECU.

Check continuity between terminal GND of ABS (& TRAC) ECU connector and body ground.

w/o TRAC

LOCK

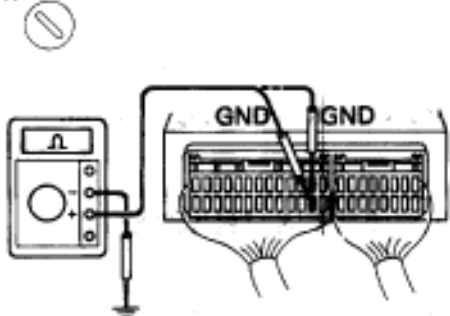

BE0063
R02983

w/ TRAC

LOCK

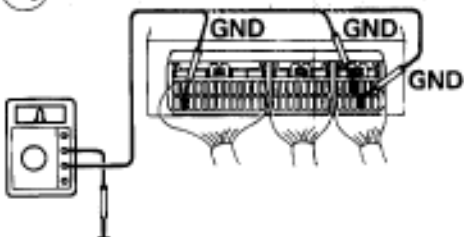

BE0063
R06928

C Measure resistance between terminals GND of ABS (& TRAC) ECU connector and body ground.

OK Resistance: 1 or less

OK

NG Repair or replace harness or connector.

Check ECU-IG fuse.

J/B No. 1

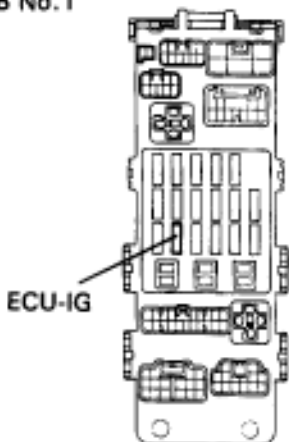

R07407

P Remove ECU-IG fuse from J/B No. 1.

C Check continuity of ECU-IG fuse.

OK Continuity

OK

NG Check for short in all the harness and components connected to ECU-IG fuse (See attached wiring diagram).

Check for open in harness and connector between ABS (& TRAC) ECU and battery (See page [IN-30](#)).

DTC 44 Lateral Acceleration Sensor Circuit

CIRCUIT DESCRIPTION

This sensor detects acceleration acting laterally on the vehicle. The sensor signal is used in ABS control. If the sensor functions abnormally, the ABS warning light comes on but the ABS still operates.

DTC No.	Diagnostic Trouble Code Detecting Condition	Trouble area
44	Either of the following (1) or (2) is detected: (1) An open or short is detected in circuit GS1 or GS2 for 1 sec. (2) After the ignition is turned ON, the test signal is output by GST. During this time, a trouble signal is detected for 0.5 sec.	Lateral acceleration sensor Open or short in lateral acceleration sensor circuit ECU

WIRING DIAGRAM

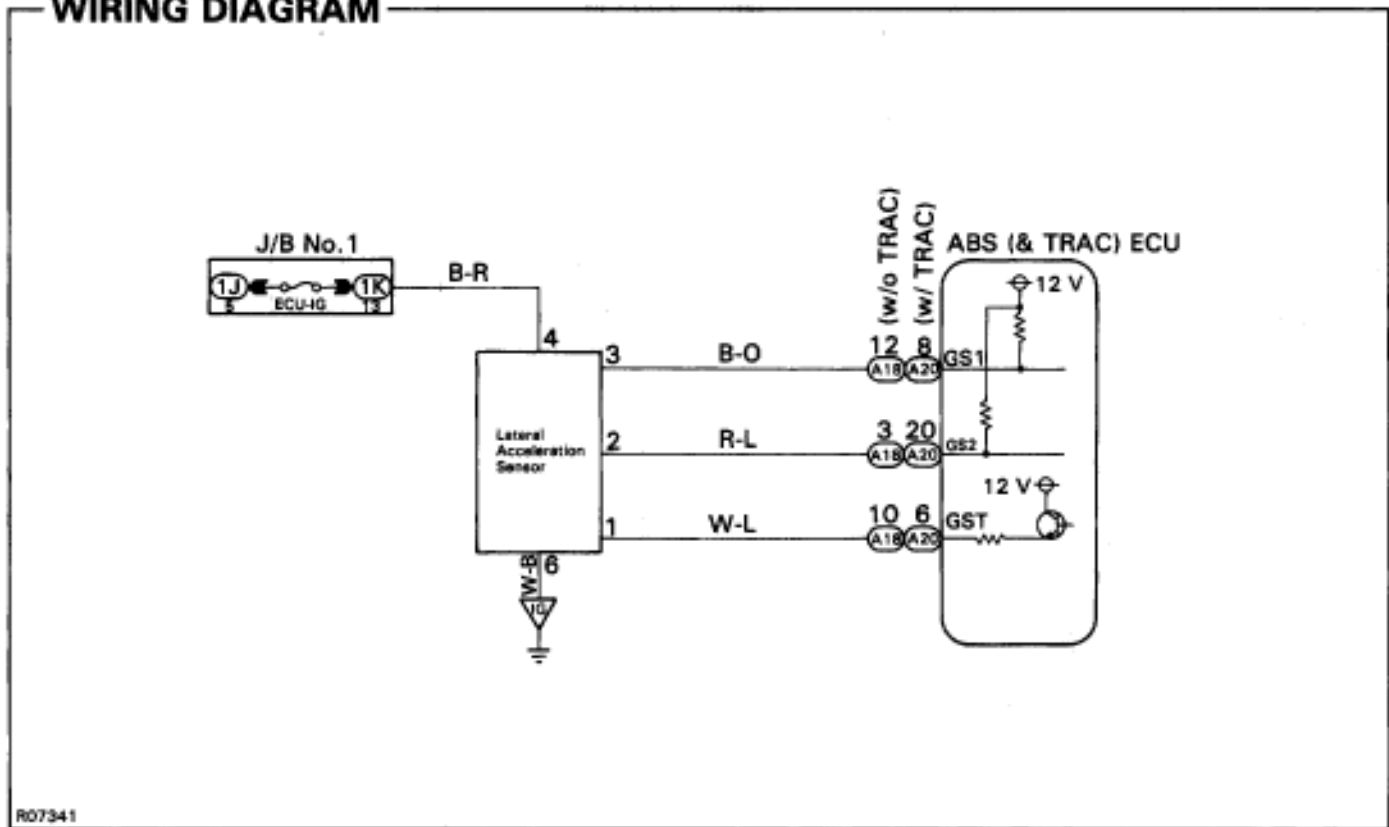

INSPECTION PROCEDURE.

1

Check for open and short in harness and connector between sensor and ECU (See page IN-30).

OK

NG

Repair or replace harness or connector.

2

Check voltage between terminals GS1, GS2, GST of ECU and body ground.

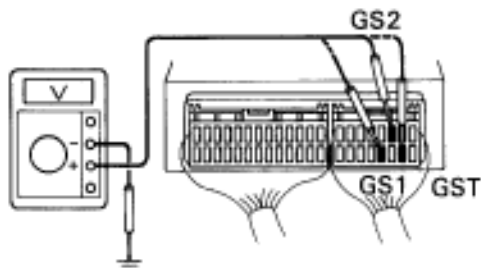
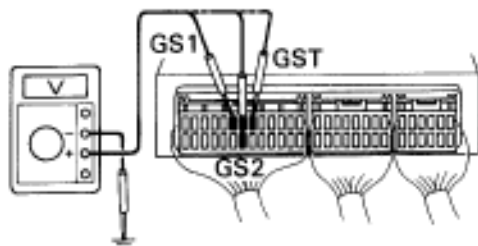
w/o TRACBE6653
R07414w/ TRACBE6653
R07415**P**

1. Remove ABS (& TRAC) ECU with connectors still connected.
1. Disconnect sensor connector.
3. Turn ignition switch ON.

C

Measure voltage between terminals GS1, GS2, GST of ECU and body ground.

OK

Voltage:

GS1, GS2: 10 — 14 V

GST: As shown below

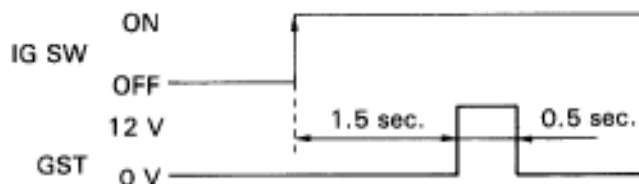

OK

NG

Check and replace ABS (& TRAC) ECU.

Check and replace lateral acceleration sensor.

DTC 51 ABS Pump Motor Lock

CIRCUIT DESCRIPTION

DTC No.	Diagnostic Trouble Code Detecting Condition	Trouble area
51	Pump motor is not operating normally during initial check.	ABS pump motor

Fail safe function: If trouble occurs in the ABS pump motor, the ECU cuts off the current to the solenoid relay and prohibits ABS control.

WIRING DIAGRAM

See page [BR-72](#)

INSPECTION PROCEDURE

See inspection of ABS actuator (See page [BR-44](#)).

DTC 55 Brake Fluid Level Warning Switch Circuit

CIRCUIT DESCRIPTION

The brake fluid level warning switch sends the appropriate signal to the ECU when the brake fluid level drops.

DTC No.	Diagnostic Trouble Code Detecting Condition	Trouble area
55	Voltage at ECU terminal LBL is 0 V continuously for 10 sec. or more.	Brake fluid level Brake fluid level warning switch Short in brake fluid level warning switch circuit ECU

Fail safe function: If trouble occurs in this circuit, the ECU cuts off current to the TRAC solenoid relay and prohibits TRAC control.

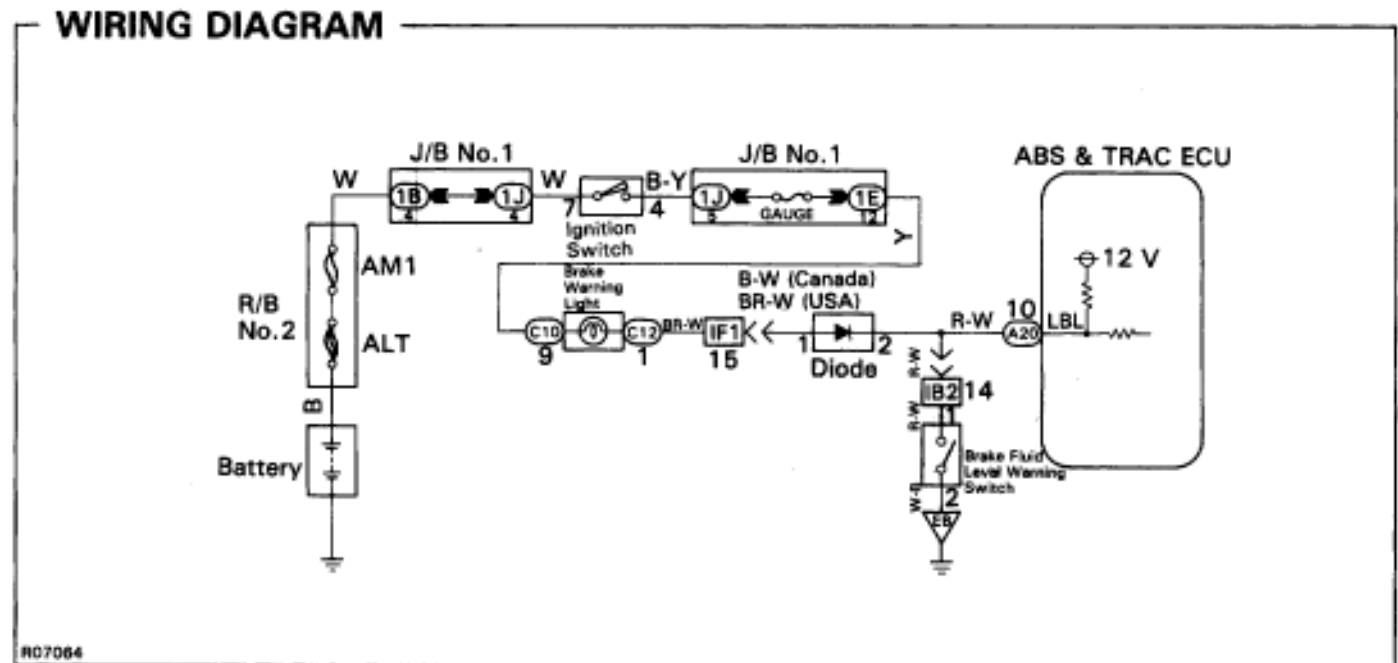

INSPECTION PROCEDURE**1** Check brake fluid level.**C** Check the amount of fluid in the brake reservoir.

OK

NG

Check and repair brake fluid leakage and add fluid.

2 Check brake fluid level warning switch.See page [BE-52](#).

OK

NG

Replace brake fluid level warning switch.

3 Check for short in all the harness and components connected to brake fluid level warning light (See page [IN-30](#)).

OK

NG

Repair or replace harness or connector.

Check and replace ABS & TRAC ECU.

DTC 58 TRAC Pump Motor Circuit

CIRCUIT DESCRIPTION

This motor is used to apply hydraulic pressure for the rear wheel brakes during TRAC control.

DTC No.	Diagnostic Trouble Code Detecting Condition	Trouble area
58	Conditions (1) through (3) continue for 2 sec. or more: (1) TRAC motor relay: Normal (2) TRAC motor: OFF (3) Voltage of ABS & TRAC ECU terminal MTT: 4-8 V	TRAC pump motor Open in TRAC pump motor circuit ECU

Fail safe function: If trouble occurs in this circuit, the ECU cuts off current to the TRAC solenoid relay and prohibits TRAC control.

WIRING DIAGRAM

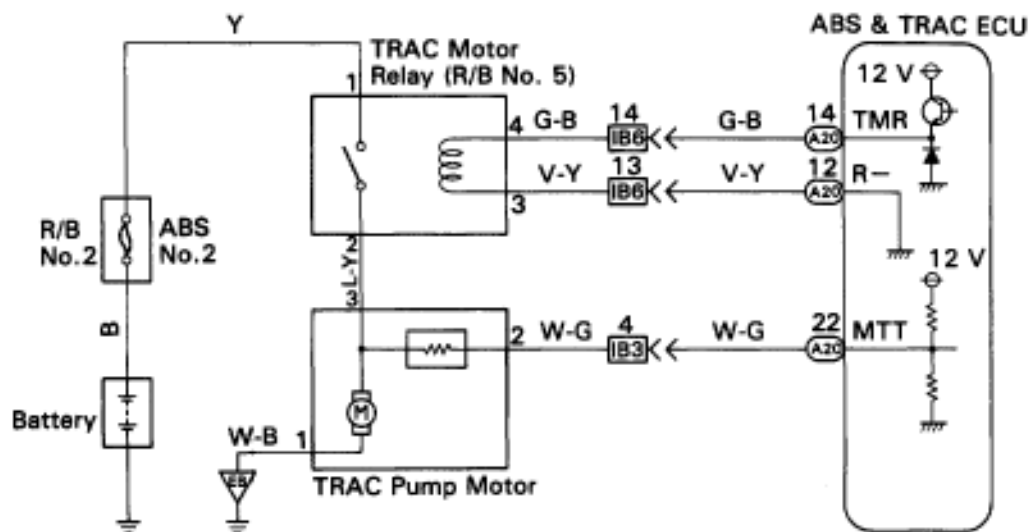

INSPECTION PROCEDURE.

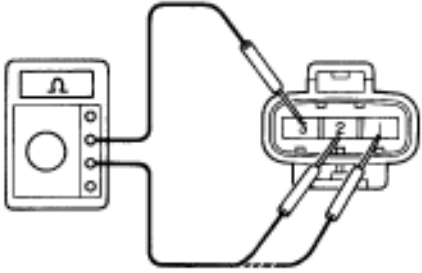
1 Check TRAC pump motor.

R07339

P Disconnect TRAC pump motor connector.**C** Check continuity between each terminal of TRAC pump motor shown below.

OK	Terminals 1 and 3	Continuity (Reference value 100 or less)
	Terminals 2 and 3	Continuity (Reference value 4 ~ 6 or less)

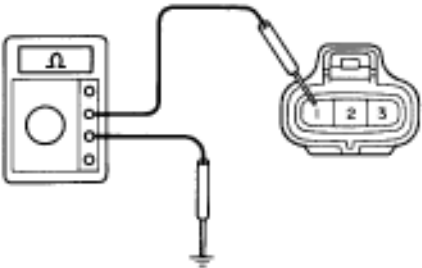
OK**NG** Replace TRAC pump motor.**2** Check continuity between terminal 1 of TRAC pump motor connector and body ground.

R07340

C Measure resistance between terminal 1 of TRAC pump motor connector and body ground.**OK** Resistance: 1 or less**OK****NG** Repair or replace harness or connector.**3** Check for open and short in harness and connector between TRAC pump motor and ECU (See page [IN-30](#)).**OK****NG** Repair or replace harness or connector.

Check and replace ABS & TRAC ECU.

DTC 61 TRAC ECU Communication Circuit Malfunction

CIRCUIT DESCRIPTION

DTC No.	Diagnostic Trouble Code Detecting Condition	Trouble area
61	<p>Either of the following (1) or (2) continues for more than 8 sec.:</p> <p>(1) Vehicle speed signal of 4 wheels is less than 1 km/h (1 mph) when TRCO signal is input.</p> <p>(2) Voltage of ABS & TRAC ECU terminal THFA is 0 V when TRCO signal is not input.</p>	<p>Open or short in THFA, TRCO circuit ABS & TRAC ECU TRAC ECU</p>

WIRING DIAGRAM

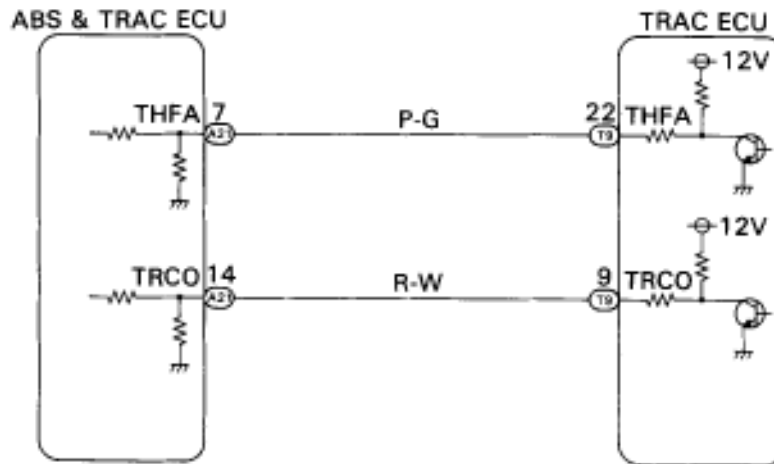

INSPECTION PROCEDURE.

1 Check voltage between terminals THFA, TRCO of ABS & TRAC ECU and body ground.

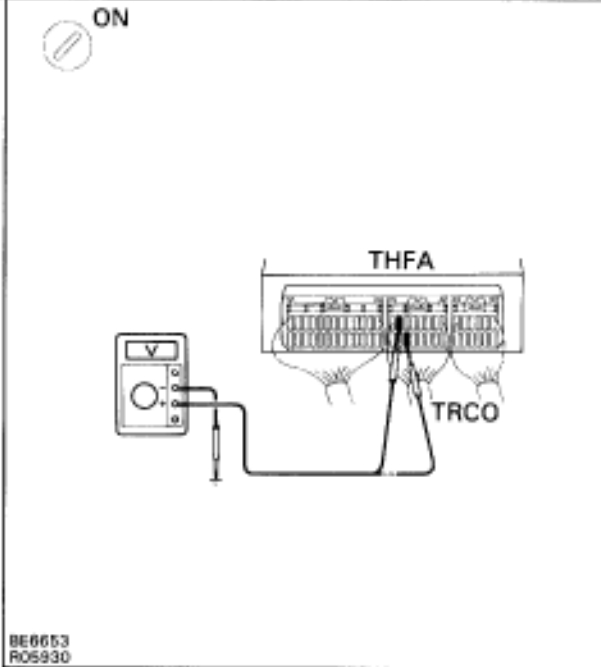

P Remove ABS & TRAC ECU with connectors still connected.

C Measure voltage between terminals THFA, TRCO of ABS & TRAC ECU and body ground when ignition switch is turned ON.

OK Voltage:
 TRCO: 7 — 12 V
 THFA: About 5 V (Pulse)

(Reference)

NG

OK Check and replace ABS & TRAC ECU.

2 Check voltage between terminals THFA, TRCO of ABS & TRAC ECU and body ground with ABS & TRAC ECU connector is disconnected.

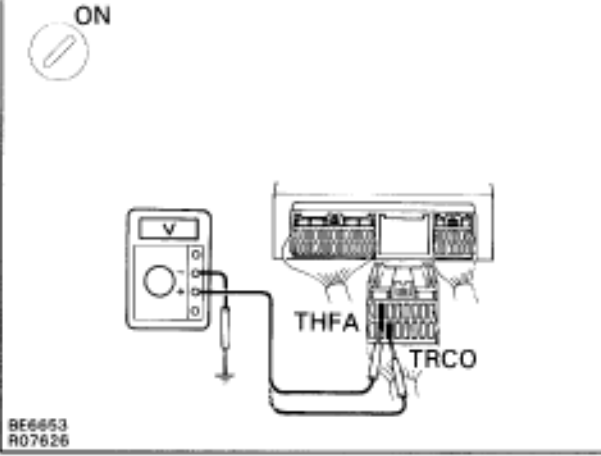

P Disconnect ABS & TRAC ECU connector.

C Measure voltage between terminals THFA, TRCO of ABS & TRAC ECU connector and body ground when ignition switch is turned ON.

OK Voltage: See step 1.

NG

OK Check and replace ABS & TRAC ECU.

3 Check for open and short in harness and connector between ABS & TRAC ECU and TRAC ECU (See page IN-30).

OK

NG Check and replace or connector.

Check and replace TRAC ECU.

DTC 62 TRAC Vehicle Speed Malfunction

CIRCUIT DESCRIPTION

DTC No.	Diagnostic Trouble Code Detecting Condition	Trouble area
62	At vehicle speed of 10 km/h (6 mph) or more, pulses are not input for 5 sec.	ECU

HINT: When DTC Nos.31 — 36 are recorded in memory, DTC No.62 is not recorded.

INSPECTION PROCEDURE

1

Are there any other codes (Besides DTC No.62) being output?

NO

YES

Go to relevant DTC chart.

Replace ABS & TRAC ECU.

Stop Light Switch Circuit

CIRCUIT DESCRIPTION

The stop light switch senses whether the brake pedal is depressed or released, and sends a signal to the ECU.

WIRING DIAGRAM

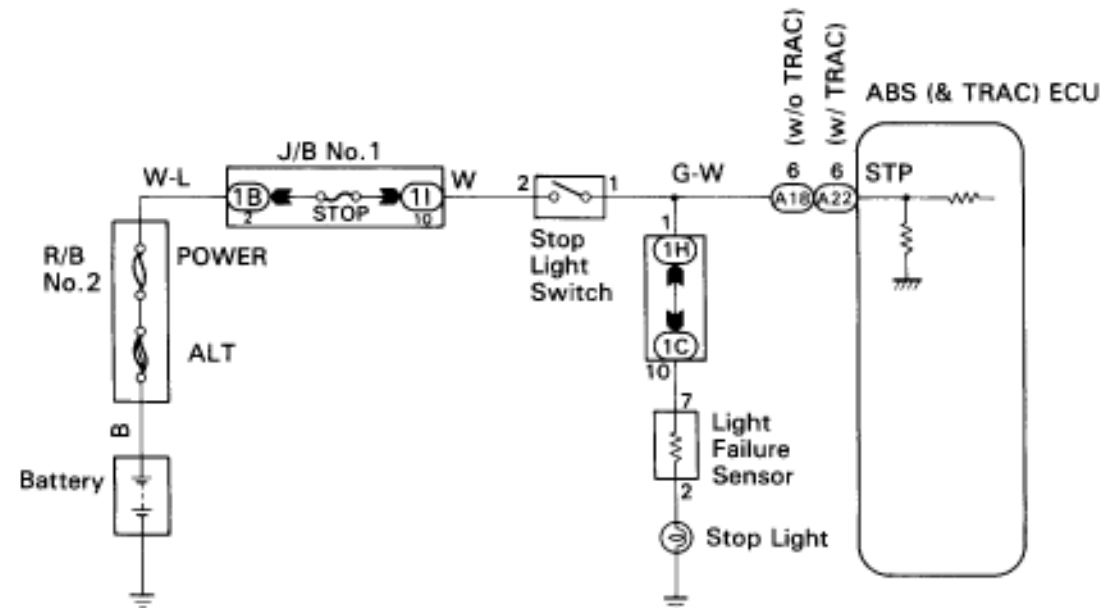

R07065

INSPECTION PROCEDURE

1 Check operation of stop light.

- C** Check the stop light lights up when brake pedal is depressed and turns off when brake pedal is released.

OK

NG Repair stop light circuit.

2 Check voltage between terminal STP of ABS (& TRAC) ECU and body ground.

w/o TRAC

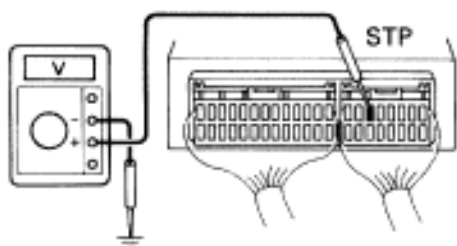

w/ TRAC

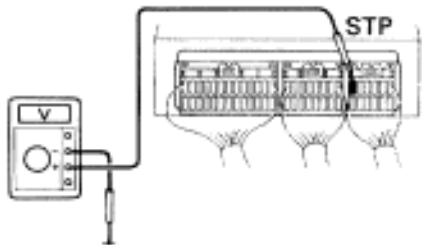

R07015
R05931

- P** Remove ABS & TRAC ECU with connectors still connected.

- C** Measure voltage between terminals STP of ABS (& TRAC) ECU and body ground when brake pedal is depressed.

- OK** Voltage: 8 – 14 V

NG

OK Proceed to next circuit inspection shown on problem symptoms chart (See page [BR-64](#)).

3 Check for open in harness and connector between ABS (& TRAC) ECU and stop light switch (See page [IN-30](#)).

OK

NG Repair or replace harness or connector.

Check and replace ABS (& TRAC) ECU.

ABS Warning Light Circuit

CIRCUIT DESCRIPTION

If the ECU detects trouble, it lights the ABS warning light while at the same time prohibiting ABS control. At this time, the ECU records a diagnostic trouble code in memory.

After removing the short pin of the DLC1, connect terminals Tc and E1 of the DLC1 or DLC2 to make the ABS warning light to blink and output the diagnostic trouble code.

WIRING DIAGRAM

w/o TRAC

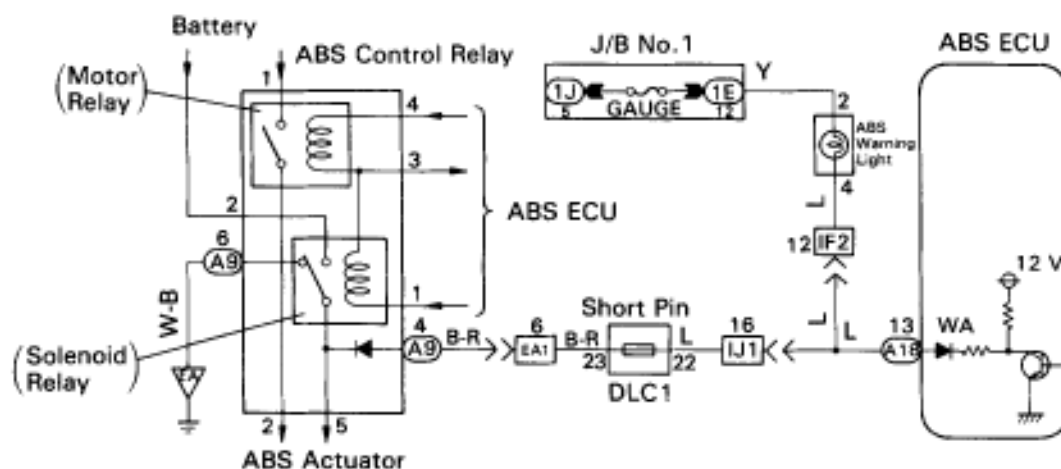

w/ TRAC

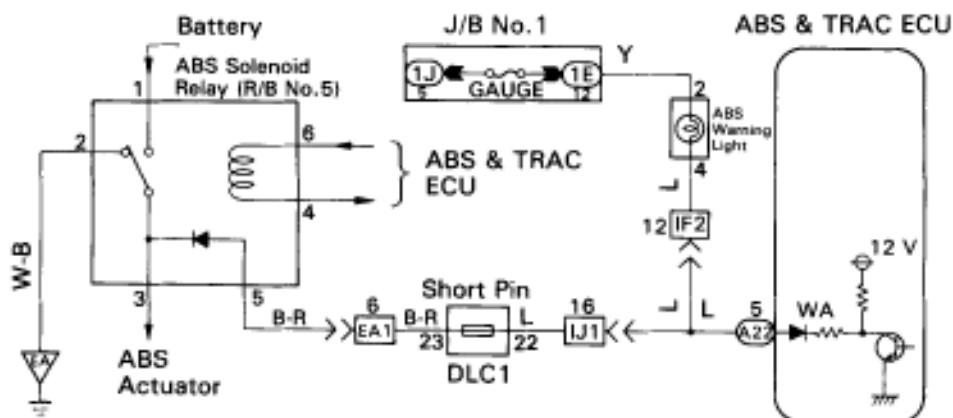

INSPECTION PROCEDURE (w/o TRAC)

Perform troubleshooting in accordance with the chart below for each trouble symptom.

ABS warning light does not light up	Go to step [1]
ABS warning light remains on	Go to step [3]

1 Check ABS warning light.

See Combination Meter Troubleshooting on page [BE-43](#).

OK

NG Replace bulb or combination meter assembly.

2 Check ABS solenoid relay.

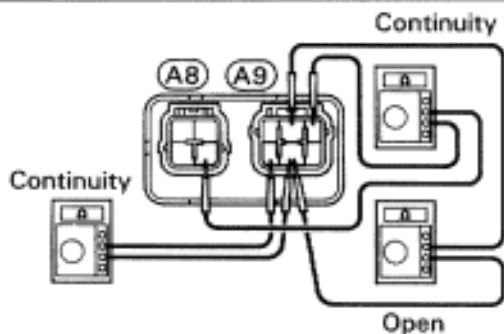

P Disconnect the connectors from solenoid relay.

C Check continuity between each terminal of ABS solenoid relay shown below.

OK

Terminals (A9) 1 and (A8) 3	Continuity (Reference value 80 Ω)
Terminals (A9) 5 and (A9) 6	Continuity
Terminals (A9) 2 and (A9) 5	Open

C (1) Apply battery positive voltage between terminals (A9) 1 and (A8) 3.
(2) Check continuity between each terminal of ABS solenoid relay shown below.

OK

Terminals (A9) 5 and (A9) 6	Open
Terminals (A9) 2 and (A9) 5	Continuity

C Connect the ⊕ test lead to terminal (A9)4 and the ⊖ lead to the terminal (A9)5. Check continuity between the terminals.

OK

Continuity

If there is no continuity, connect the ⊖ test lead to terminal (A9)4 and the ⊕ lead to terminal (A9)5. Recheck continuity between terminals.

OK

NG Replace ABS control relay.

R00889
R00895
R00940

Repair or replace and check for open in harness and connector between DLC1 and ABS solenoid relay and body ground (See page [IN-30](#)).

3 Is diagnostic trouble code output?

Do diagnostic trouble code check on page [BR-54](#).

NO**YES** Repair circuit indicated by the code output.**4** Does ABS warning light go off if short pin is removed?**YES****NO** Check for short in harness and connector between warning light and DLC1 and ECU (See page [IN-30](#)).**5** Check ABS solenoid relay (See step No.2).**OK****NG** Repair ABS control relay.

Repair or replace and check for short in harness and connector between DLC1 and ABS solenoid relay (See page [IN-30](#)).

INSPECTION PROCEDURE (w/ TRAC)

Troubleshoot in accordance with the chart below for each trouble symptom.

ABS warning light does not light up	Go to step [1]
ABS warning light remains on	Go to step [3]

1 Check ABS warning light.

See Combination Meter Troubleshooting on page [BE-43](#).

OK

NG Replace bulb or combination meter assembly.

2 Check ABS solenoid relay.

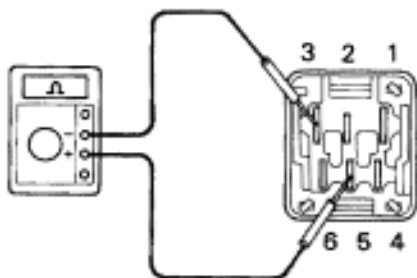
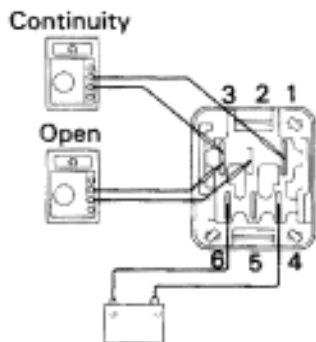
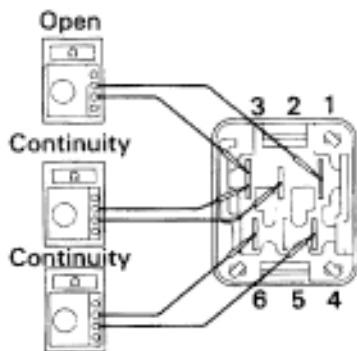

BR5404
BR5405
R07081

P Disconnect the connectors from R/B No.5.

C Check continuity between each terminal of ABS solenoid relay shown below.

OK

Terminals 4 and 6	Continuity (Reference value 80)
Terminals 2 and 3	Continuity
Terminals 1 and 3	Open

C 1. Apply battery positive voltage between terminals 4 and 6.
2. Check continuity between each terminal of ABS solenoid relay shown below.

OK

Terminals 2 and 3	Open
Terminals 1 and 3	Continuity

C Connect the \oplus test lead to terminal 5 and the \ominus lead to the terminal 3. Check continuity between the terminals.

OK

Continuity

If there is no continuity, connect the \ominus test lead to terminal 5 and the \oplus lead to terminal 3. Recheck continuity between terminals.

OK

NG Replace ABS solenoid relay.

Repair or replace and check for open in harness and connector between DLC1 and ABS solenoid relay and body ground (See page [IN-30](#)).

3 Is diagnostic trouble code output?

Do diagnostic trouble code check on page [BR-54](#).

NO**YES**

Repair circuit indicated by the code output.

4 Does ABS warning light go off if short pin is removed?**YES****NO**Check for short in harness and connector between warning light and DLC1 and ECU (See page [IN-30](#)).**5** Check ABS solenoid relay (See step No. 2).**OK****NG**

Replace ABS solenoid relay.

Repair or replace and check for short in harness and connector between DLC1 and ABS solenoid relay (See page [IN-30](#)).

Tc Terminal Circuit

CIRCUIT DESCRIPTION

Connecting terminals Tc and E1 of the DLC1 or the DLC2 causes the ECU to display the diagnostic trouble code by flashing the ABS warning light.

WIRING DIAGRAM

w/o TRAC

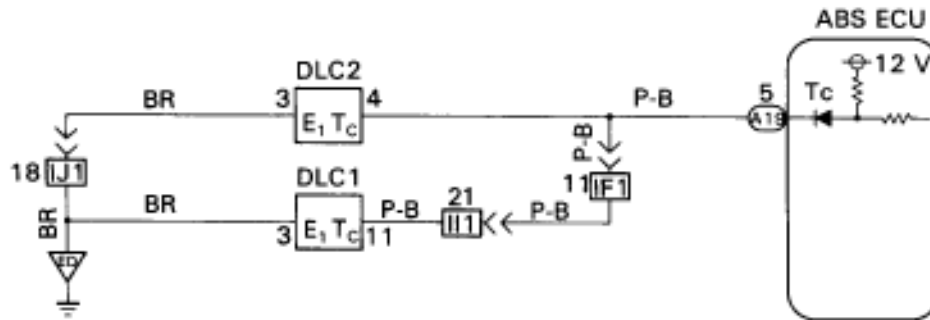

w/ TRAC

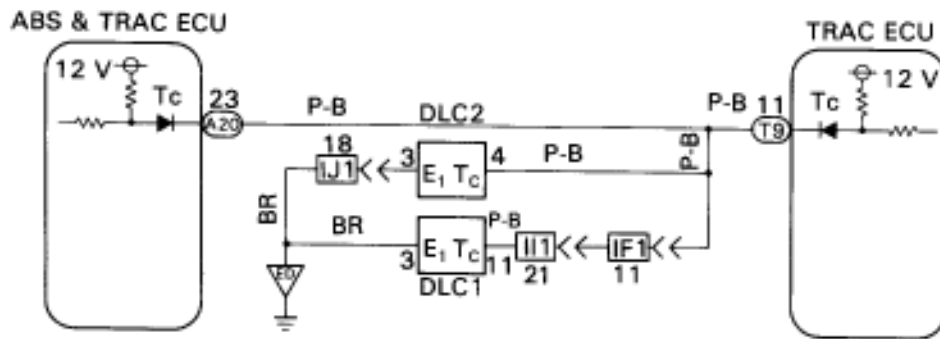

INSPECTION PROCEDURE.

1

Check voltage between terminals Tc and E1 of DLC2 or DLC1.

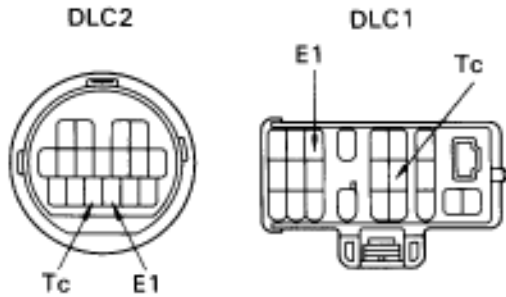

S-17-1
16i-23-1-A

- P** Turn ignition switch ON.
- C** Measure voltage between terminals Tc and E1 of DLC2 or DLC1.
- OK** Voltage: 10 - 14 V

NG

OK

If ABS warning light does not blink even after Tc and E1 are connected, the ECU may be defective.

2

Check for open and short in harness and connector of systems connected to Tc terminal (See page IN-30).

OK

NG

Repair or replace harness or connector.

Check or replace ABS (& TRAC) ECU.

Ts Terminal Circuit

CIRCUIT DESCRIPTION

The sensor check circuit detects abnormalities in the speed sensor signal which cannot be detected with the diagnostic trouble code check.

Connecting terminals Ts and E1 of the DLC1 in the engine compartment starts the check.

WIRING DIAGRAM

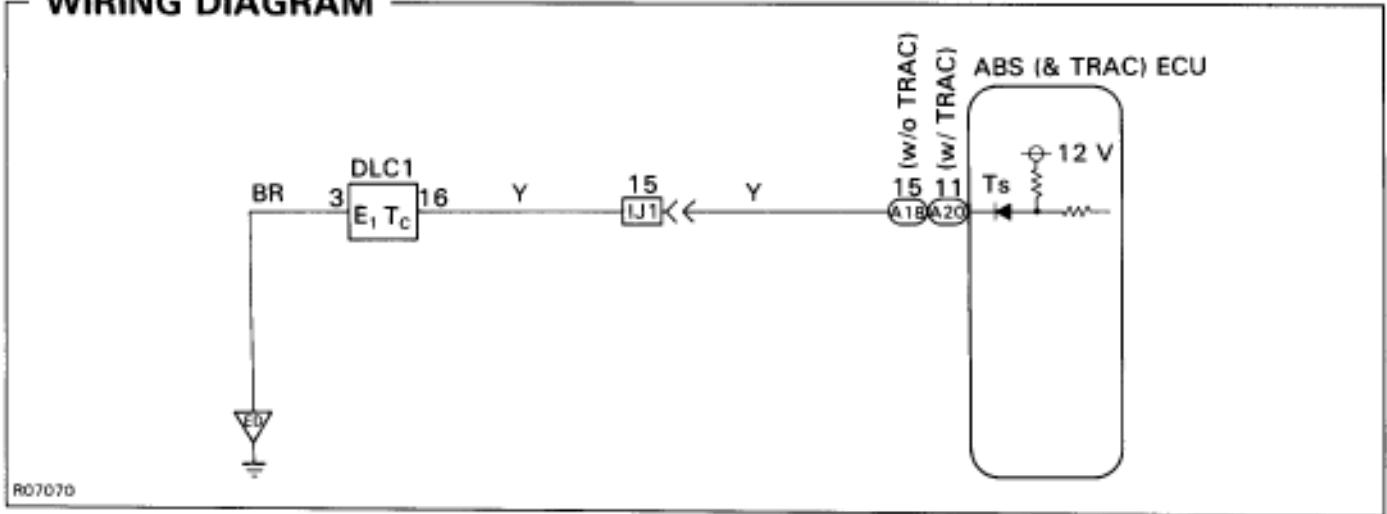

INSPECTION PROCEDURE.

1

Check voltage between terminals Ts and E1 of DLC1.

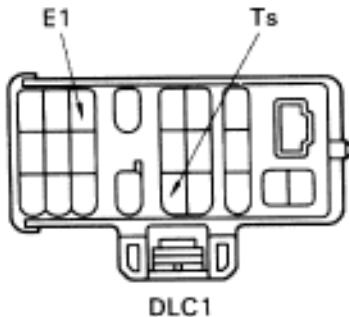

- P** Turn ignition switch ON.
- C** Measure voltage between terminals Ts and E1 of DLC1.
- OK** Voltage: 10 – 14 V

NG
OK

If ABS warning light does not blink even after Ts and E1 are connected, the ECU may be defective.

2

Check for open and short in harness and connector between ABS (&TRAC) ECU and DLC1, DLC1 and body ground (See page [IN-30](#)).

OK
NG

Repair or replace harness or connector.

Check and replace ABS (& TRAC) ECU.

Check for Fluid Leakage

Check for fluid leakage from actuator or hydraulic lines.

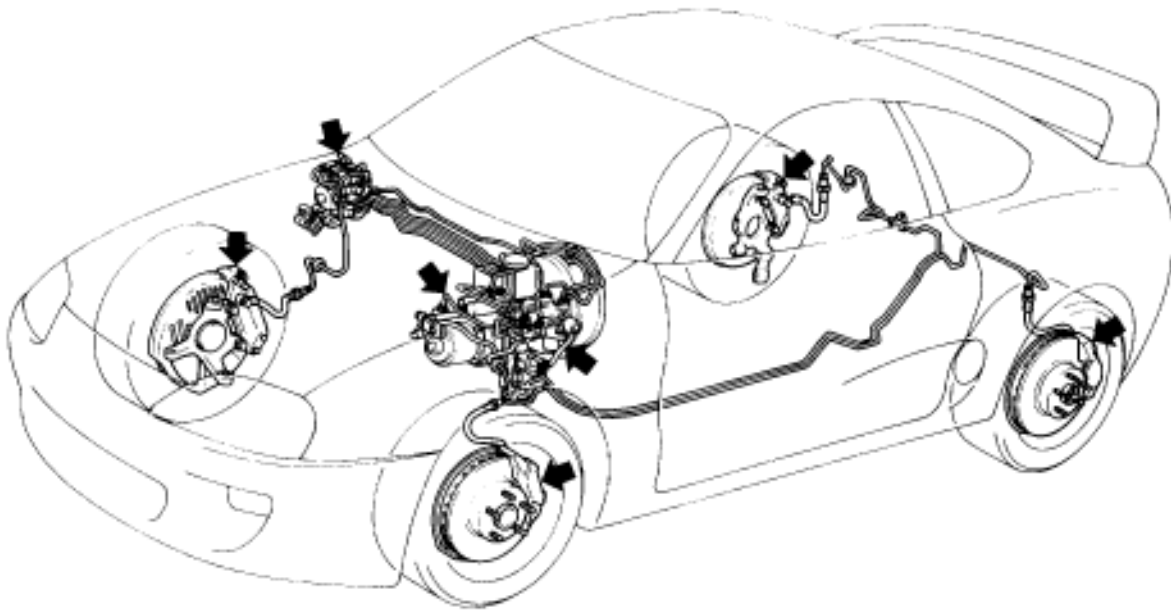

R07201

TRACTION CONTROL SYSTEM (TRAC)

TRAC PUMP COMPONENTS

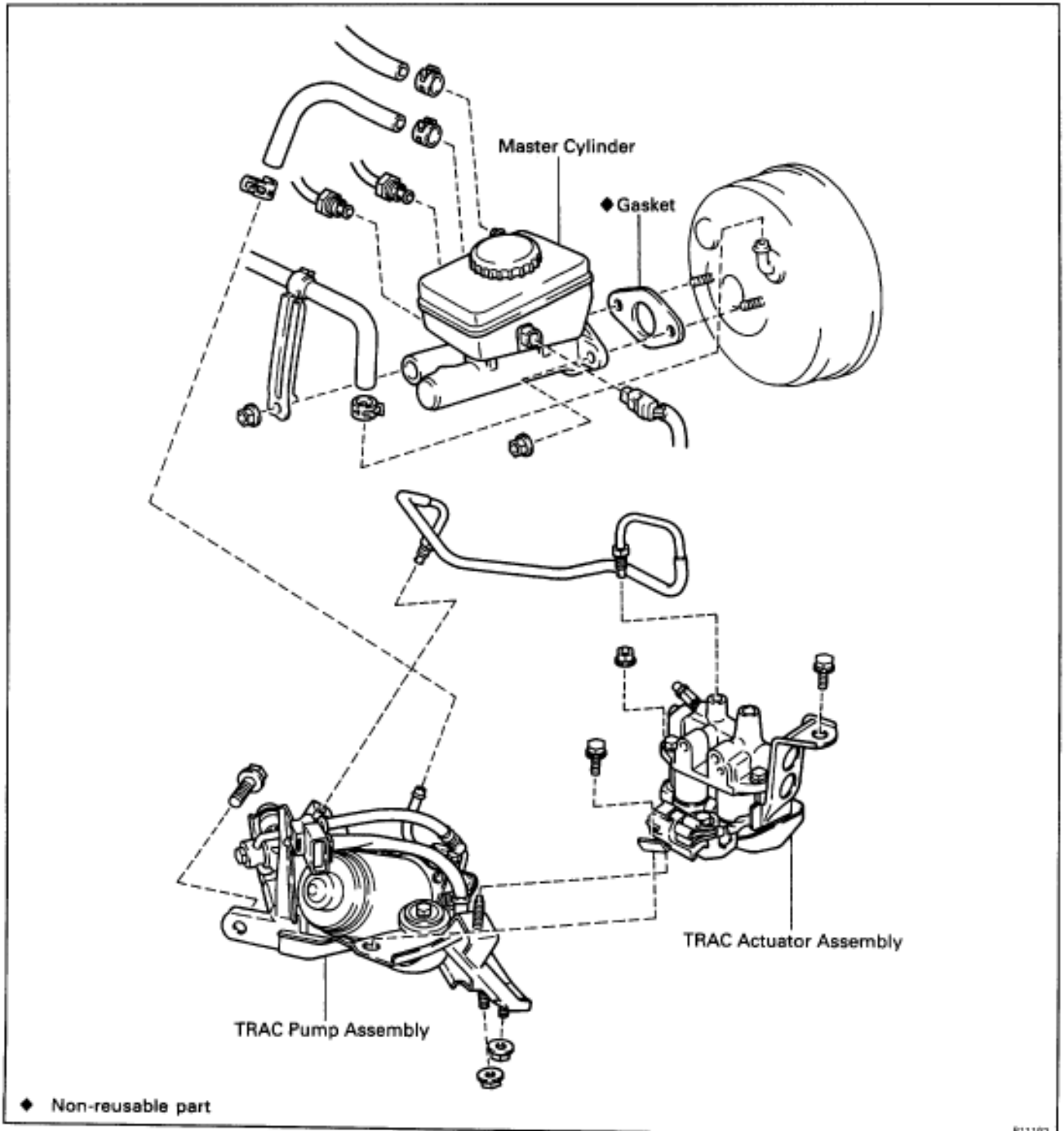

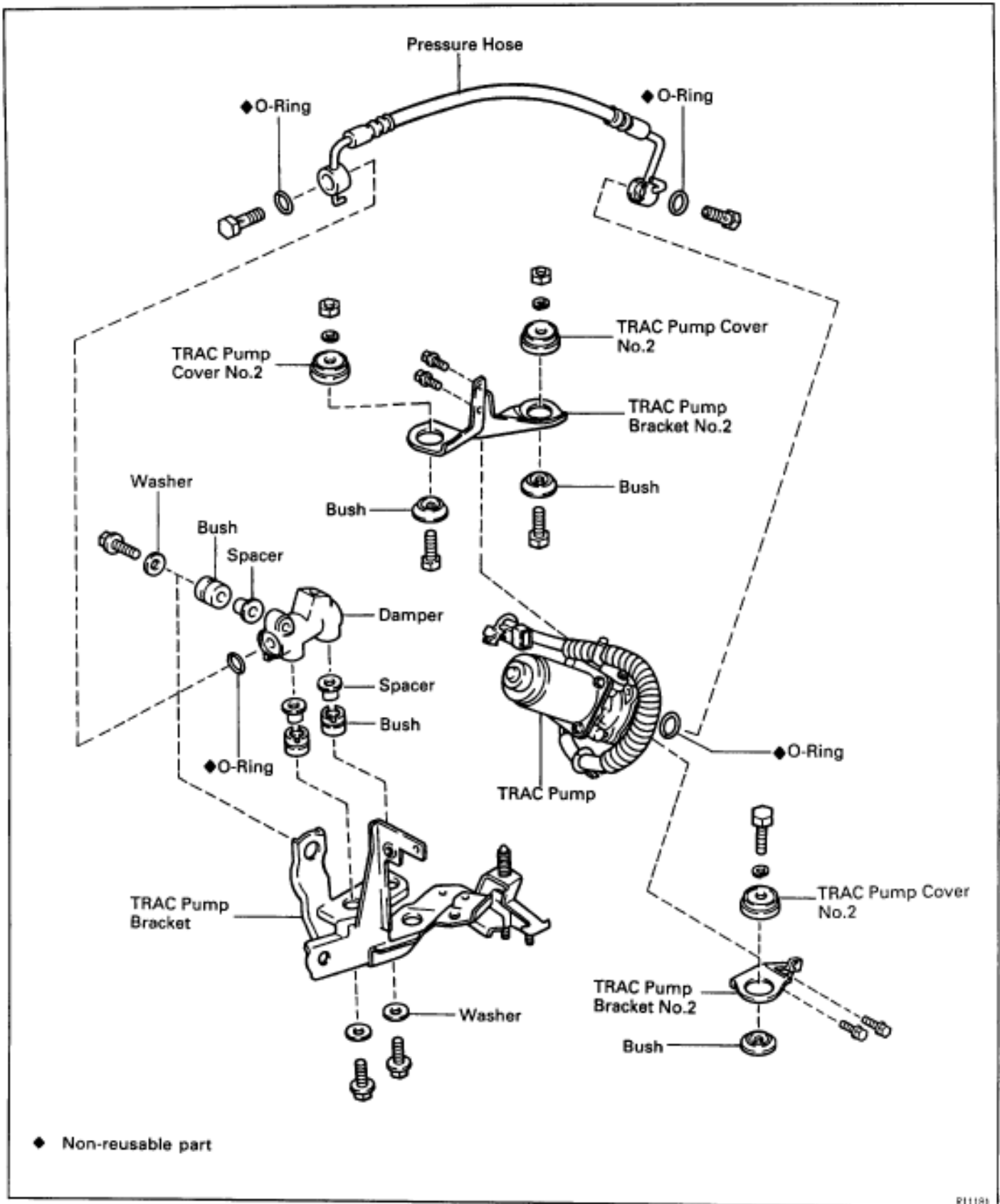

TRAC PUMP REMOVAL

Installation is in the reverse order of removal.

AFTER INSTALLATION, BLEED BRAKE SYSTEM

(See page BR-7) AND BLEED TRAC SYSTEM (See page BR-9)

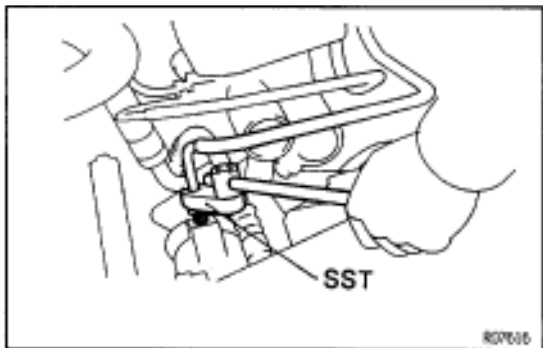

1. **REMOVE TRAC ACTUATOR**
(See page BR-121)
2. **REMOVE BRAKE MASTER CYLINDER**
(See page BR-11)
3. **DISCONNECT BRAKE LINE**
Using SST, disconnect the brake line from the damper.
SST 09023-00100
Torque: 15 N·m (155 kgf·cm, 11 ft·lbf)
4. **REMOVE TRAC PUMP ASSEMBLY**
Remove the bolt, 2 nuts and TRAC pump assembly.
Torque: 19 N·m (195 kgf·cm, 14 ft·lbf)
5. **REMOVE PRESSURE HOSE**
Remove the 2 union bolts, 4 O-rings and pressure hose.
Torque: 46 N·m (465 kgf·cm, 34 ft·lbf)
6. **REMOVE DAMPER**
Remove the 3 bolts, washers, bushings, spacers and damper.
Torque: 7.8 N·m (80 kgf·cm, 69 in·lbf)
7. **REMOVE TRAC PUMP**
Remove the 3 bolts, 2 nuts, washers, TRAC pump bracket bushings and TRAC pump.
Torque: 7.8 N·m (80 kgf·cm, 69 in·lbf)
8. **REMOVE TRAC PUMP BRACKET No.2**
Remove the 4 bolts and 2 TRAC pump bracket No.2.
Torque: 7.8 N·m (80 kgf·cm, 69 in·lbf)

TRAC ACTUATOR COMPONENTS

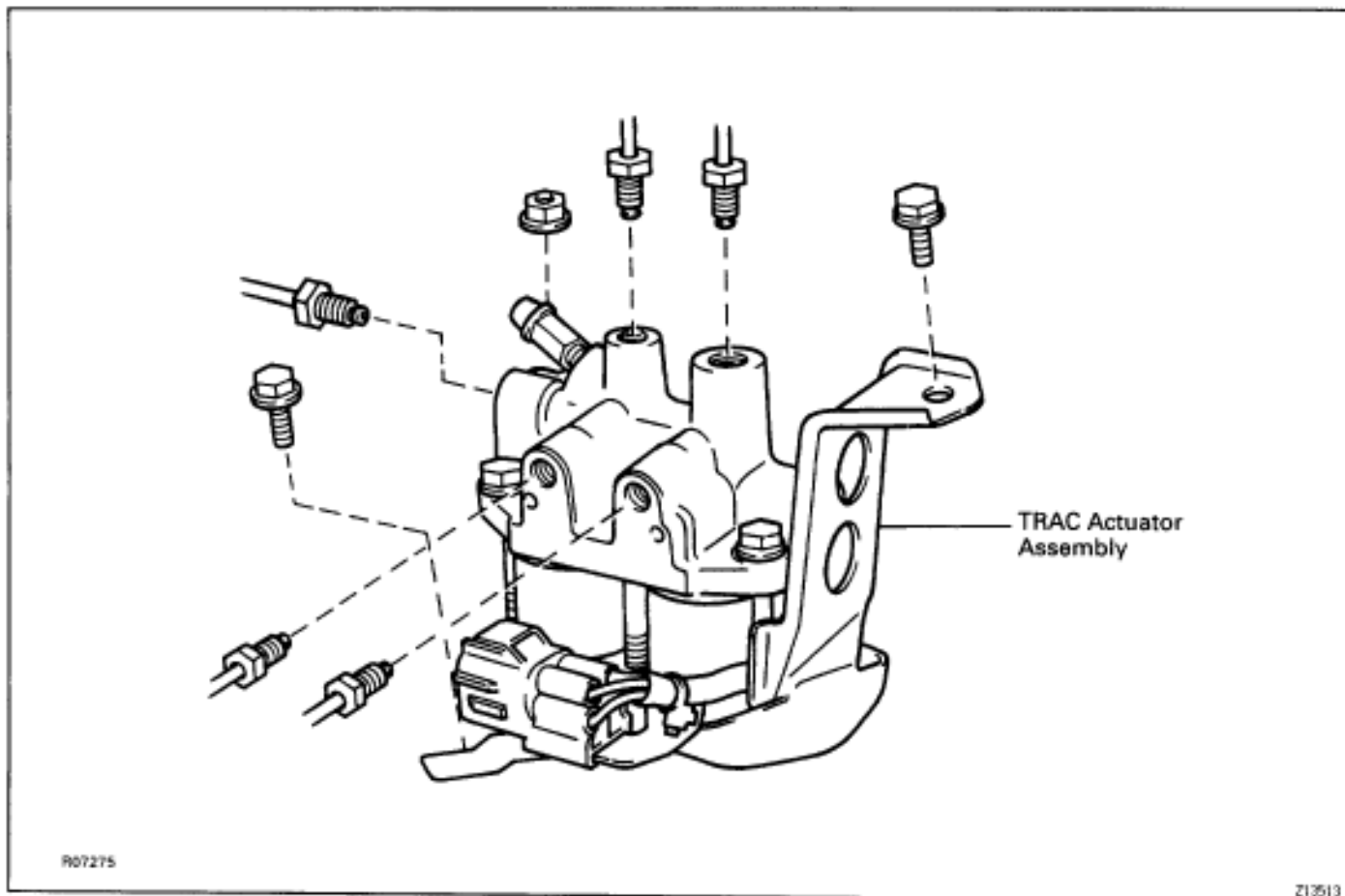

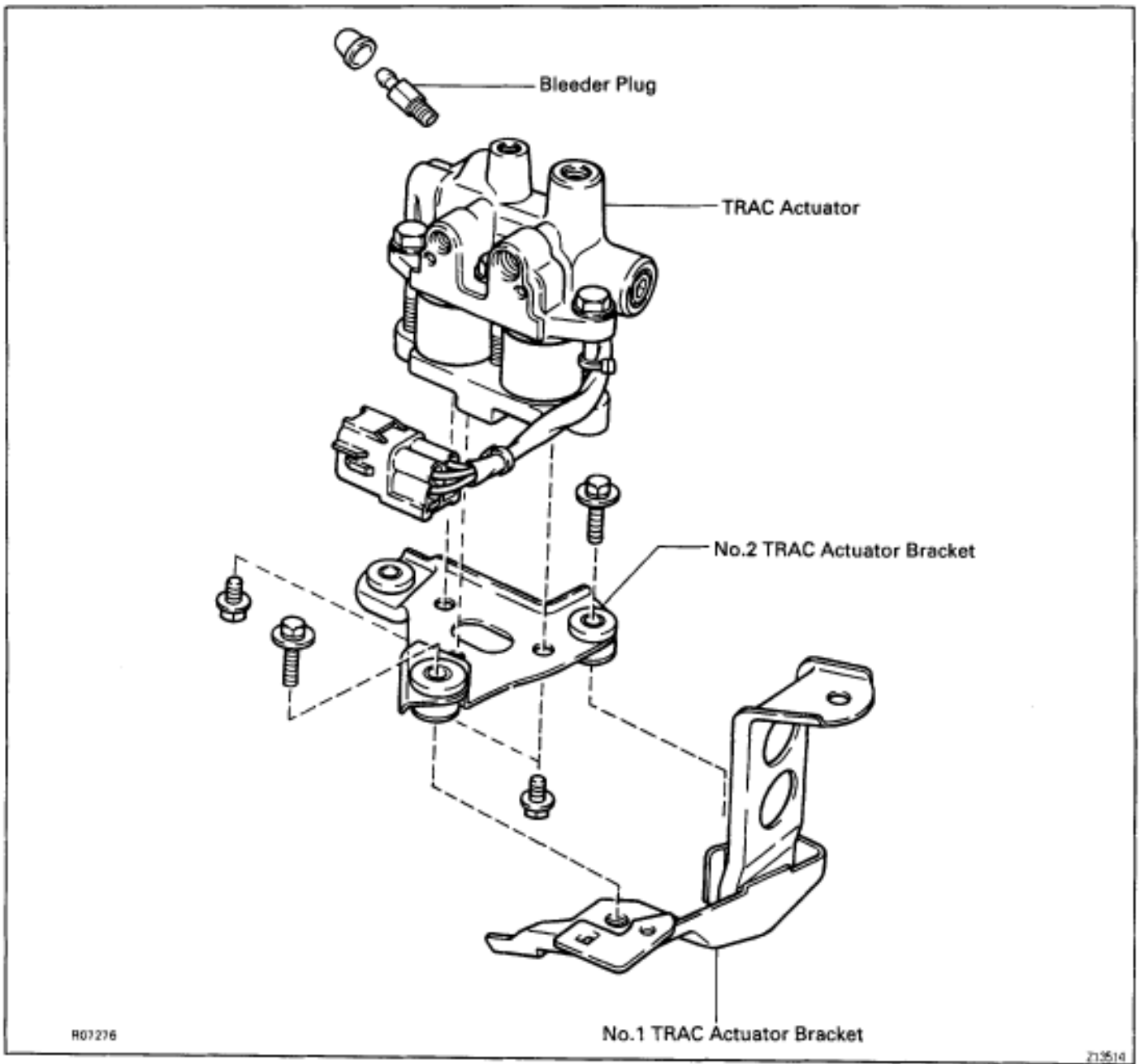

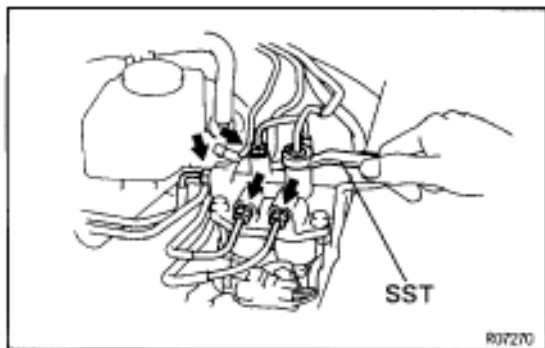

TRAC ACTUATOR REMOVAL

Installation is in the reverse order of removal.

AFTER INSTALLATION, BLEED BRAKE SYSTEM (See page BR-7) AND BLEED TRAC SYSTEM (See page BR-9)

1. DISCONNECT BRAKE LINES

Using SST, disconnect the brake lines from the TRAC actuator.

SST 09751-36011

Torque: 15 N·m (155 kgf·cm, 11 ft·lbf)

2. REMOVE TRAC ACTUATOR ASSEMBLY

Remove the 2 bolts, nut and TRAC actuator assembly.

Torque: 13 N·m (130 kgf·cm, 9 ft·lbf)

3. REMOVE TRAC ACTUATOR

Remove the 3 bolts and actuator from the bracket.

Torque: 13 N·m (130 kgf·cm, 9 ft·lbf)

4. SEPARATE TRAC ACTUATOR BRACKET

Remove the 2 bolts and separate the bracket.

Torque: 13 N·m (130 kgf·cm, 9 ft·lbf)

-MEMO-

TROUBLESHOOTING

HOW TO PROCEED WITH TROUBLESHOOTING

Perform troubleshooting in accordance with the procedure on the following pages.

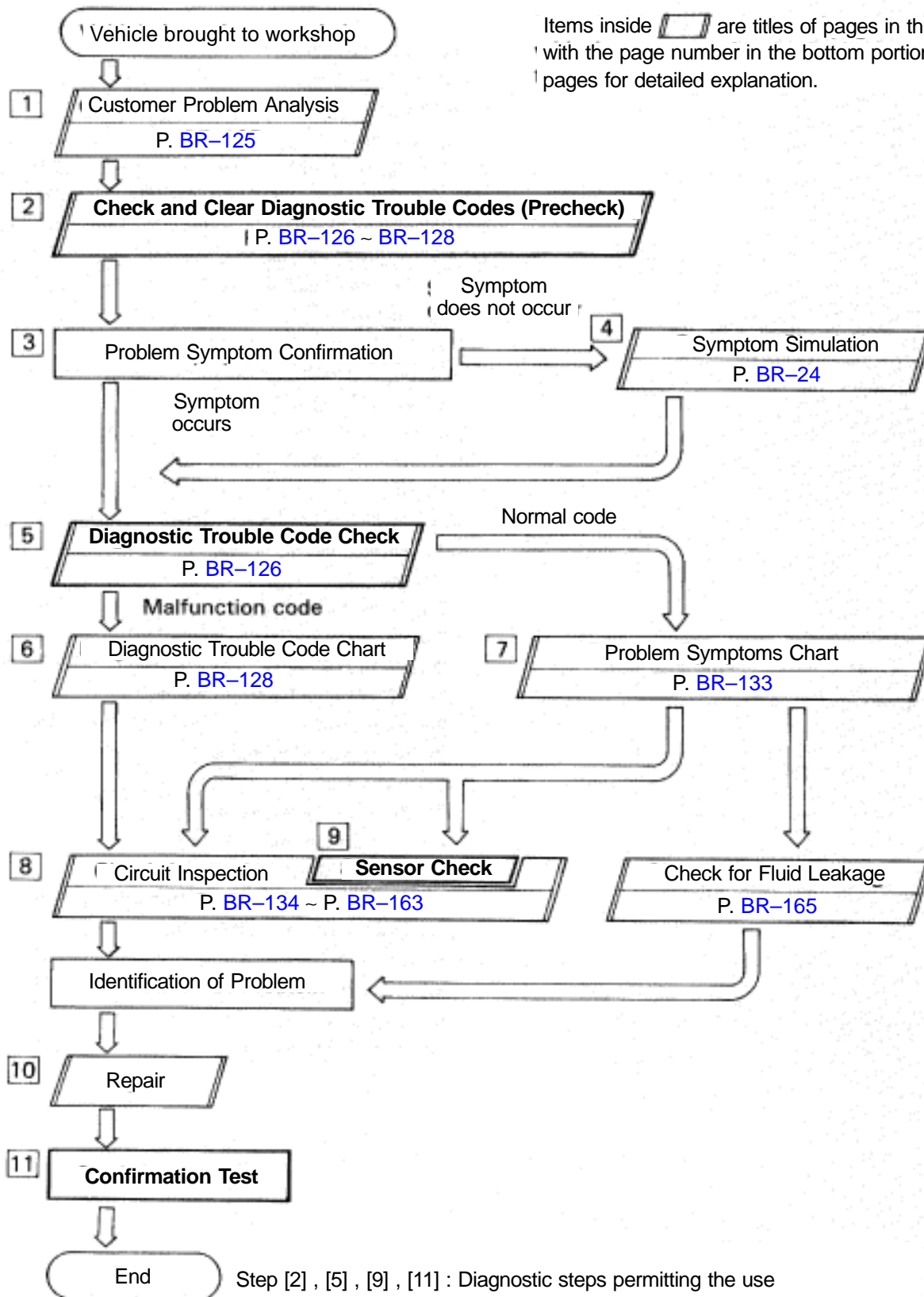

CUSTOMER PROBLEM ANALYSIS CHECK SHEET

TRAC Check Sheet

Inspector's

Name: _____

Customer's Name		Registration No.	
		Registration Year	/ /
		Frame No.	
Date Vehicle Brought In	/ /	Odometer Reading	km Miles

Date Problem First Occurred	/ /
Frequency Problem Occurs	<input type="checkbox"/> Continuous <input type="checkbox"/> Intermittent (Times a day)

Symptoms	<input type="checkbox"/> TRAC does not operate. (Wheels spin when starting rapidly).	
	TRAC Indicator Light Abnormal	<input type="checkbox"/> Remains ON <input type="checkbox"/> Blinks Does not Light Up
	TRAC OFF Indicator Light Abnormal	<input type="checkbox"/> Remains ON <input type="checkbox"/> Does not Light Up

Check Item	ABS Warning Light	<input type="checkbox"/> Normal <input type="checkbox"/> Malfunction Code (Code)
	Malfunction Indicator Lamp	<input type="checkbox"/> Normal <input type="checkbox"/> Malfunction Code (Code)

Diagnostic Trouble Code Check	1st Time	<input type="checkbox"/> Normal Code <input type="checkbox"/> Malfunction Code (Code)
	2nd Time	<input type="checkbox"/> Normal Code <input type="checkbox"/> Malfunction Code (Code)



DIAGNOSIS SYSTEM INDICATOR CHECK

When the ignition switch is turned ON, check that the TRAC indicator light goes on for 3 seconds.

HINT: If the indicator check result is not normal, proceed to troubleshooting for the TRAC indicator light circuit (See page [BR-162](#)).

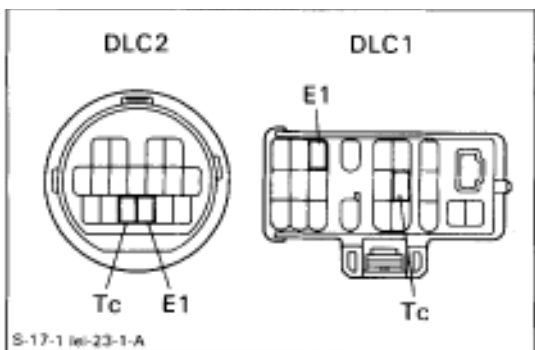

DIAGNOSTIC TROUBLE CODE CHECK

1. Turn the ignition switch ON.
2. Using SST connect terminals Tc and E1 of DLC2 or DLC1. SST 09843-18020
3. Read the diagnostic trouble code from the TRAC indicator light on the combination meter.

HINT: If no code appears, inspect the diagnostic circuit or TRAC indicator light circuit (See page [BR-162](#) or [BR-163](#))

As an example, the blinking patterns for normal code and code 32 are shown on the left.

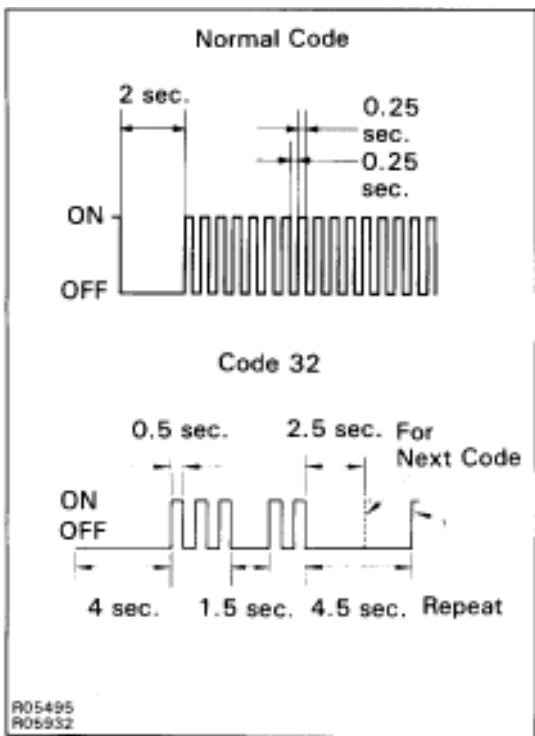

4. Codes are explained in the code table on page [BR-128](#).
5. After completing the check, disconnect terminals Tc and E1, and turn off the display.

If 2 or more malfunctions are indicated at the same time, the lowest numbered diagnostic trouble code will be displayed first.

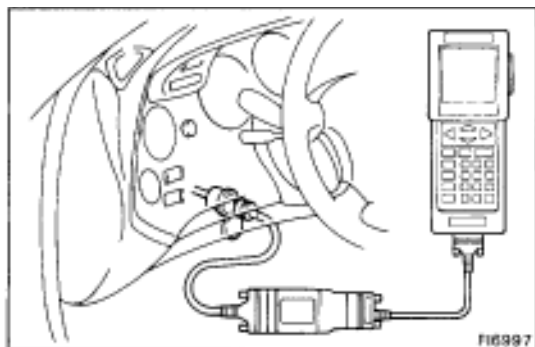

ECU DATA MONITOR USING TOYOTA HAND-HELD TESTER

1. Hook up the TOYOTA hand-held tester to the DLC2
2. Monitor the ECU data by following the prompts on the tester screen.

HINT: TOYOTA hand-held tester has a "Snapshot" function which records the monitored data.

Please refer to the TOYOTA hand-held tester operator's manual for further details.

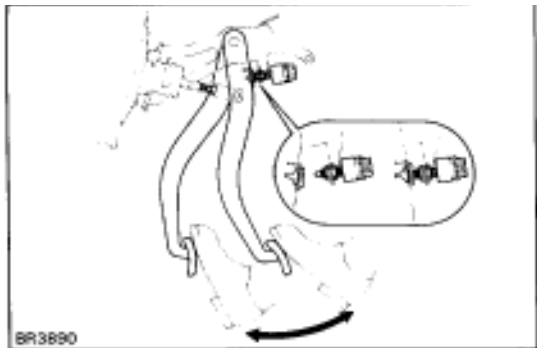

DIAGNOSTIC TROUBLE CODE CLEARANCE















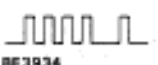

1. Using SST, connect terminals Tc and E1 of DLC2 or DLC1.
SST 09843-18020
2. IG switch ON.
3. Clear the diagnostic trouble codes stored in ECU by depressing the brake pedal 8 or more times within 3 seconds.
4. Check that the TRAC indicator light shows the normal code.
5. Remove the SST from the terminals of DLC2 or DLC1.

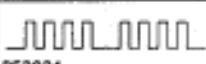
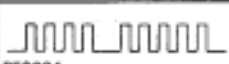
HINT: Cancellation can also be done by removing the ECU-B fuse, but in this case, other memory systems will also be cancelled out.

DIAGNOSTIC TROUBLE CODE CHART

If a malfunction code is displayed during the diagnostic trouble code check, check the circuit listed for that code in the table below and proceed to the relevant page.

HINT: If the TRAC indicator light lights up and the TRAC indicator light does not blink when the DTC is checked, check the blinking pattern of the ABS warning light and troubleshoot the ABS system.

Code	TRAC Indicator Light Blinking Pattern	Diagnosis	See page
24	 BE3932	Open or short in sub-throttle actuator circuit	BR-134
25	 BE3932	Step motor does not move to a position decided by ECU	BR-137
26	 BE3932	Sub-throttle valve does not move even when the sub-throttle valve is controlled to fully open position by ECU	BR-137
31	 BE3933	Right front wheel speed sensor signal malfunction	BR-138
32	 BE3933	Left front wheel speed sensor signal malfunction	BR-138
33	 BE3933	Right rear wheel speed sensor signal malfunction	BR-138
34	 BE3933	Left rear wheel speed sensor signal malfunction	BR-138
41	 BE3934	Low battery positive voltage or abnormally high battery positive voltage	BR-142
43*1	 BE3934	Malfunction in ABS or TRAC (BRAKE) control system	BR-145
44	 BE3934	Open or short in NE signal circuit	BR-147
45	 BE3934	Main throttle position sensor circuit malfunction	BR-149
46*2	 BE3934	Open or short in main throttle position sensor circuit	BR-149
47	 BE3934	Sub-throttle position sensor circuit malfunction	BR-152
48	 BE3934	Open or short in sub-throttle position sensor circuit	BR-152
51*3	 BE3935	Engine & ECT system malfunction	BR-155
53*4	 BE3935	ECM communication circuit malfunction	BR-156
61	 BE3936	ABS & TRAC ECU communication circuit malfunction	BR-157
Always ON		Malfunction in TRAC ECU	—

*1: If a malfunction is detected in ABS the TRAC OFF indicator light lights up instead of the TRAC indicator light.

*2: The TRAC indicator light does not light up even if an error is detected

*3: If a malfunction is detected, the TRAC OFF indicator light lights up instead of the TRAC indicator light.

*4: Depending on the malfunction, the TRAC indicator light does not light up.

PARTS LOCATION

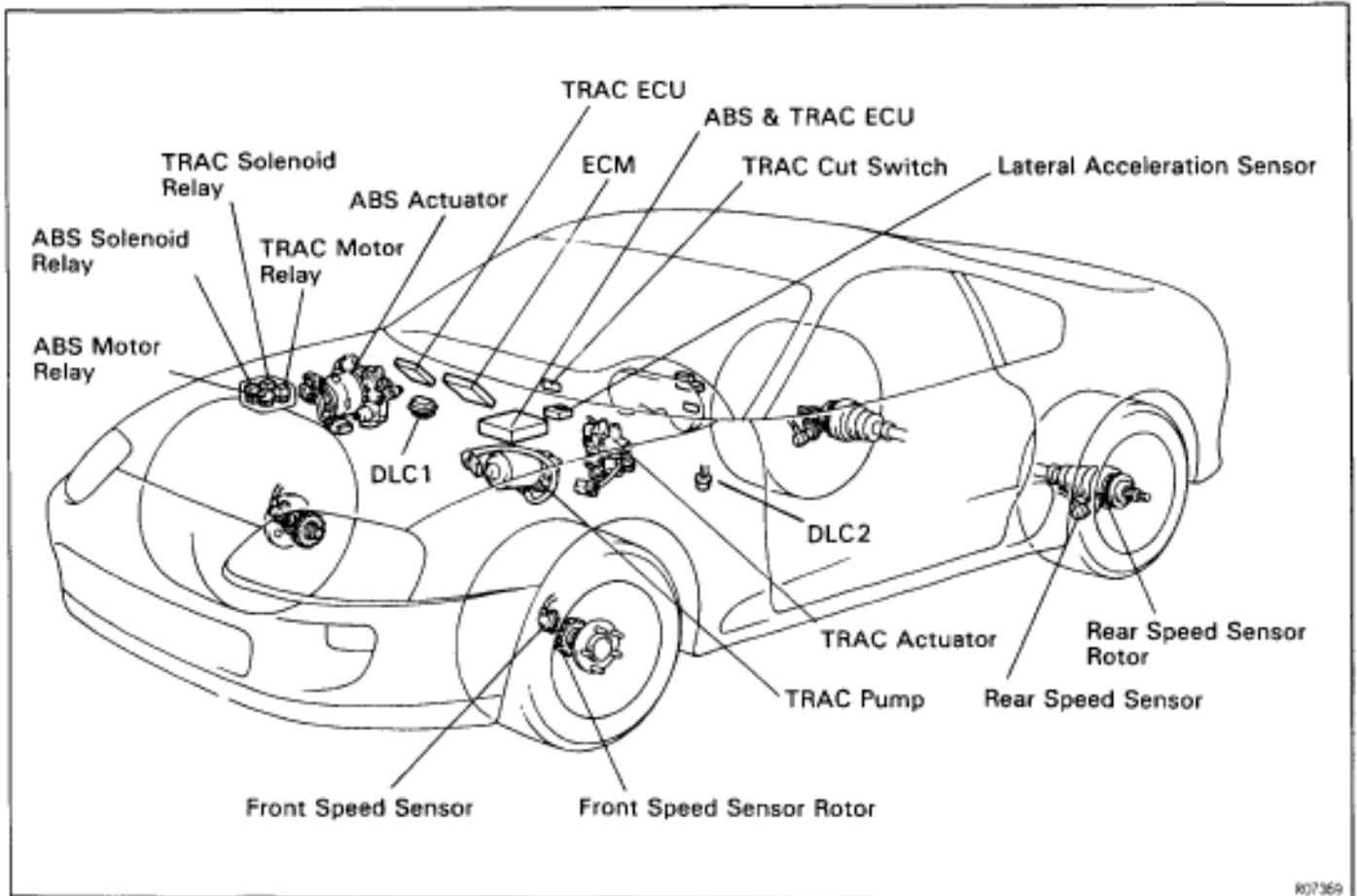

ECU TERMINALS STANDARD VALUE

ABS & TRAC ECU:

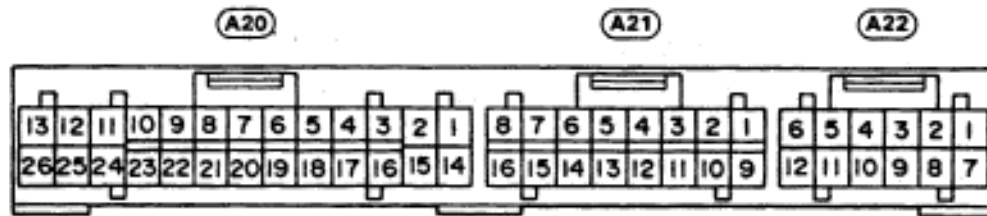

R0569B

Symbols (Terminals No.)	STD Voltage (V)	Condition
BAT (A20-7) — GND (A20-25)	10 – 14	Always
IG 1 (A20-24) — GND (A20-25)	10 – 14	IG switch ON
SR (A20-15) — R— (A20-12)	8.3 – 14	IG switch ON, ABS warning light OFF
MR (A20-2) — R— (A20-12)	Below 1.0	IG switch ON
TSR (A20-1) — R— (A20-12)	8.3 – 14	IG switch ON, TRAC and TRAC OFF indicator light OFF
TMR (A20-14) — R— (A20-12)	Below 1.0	IG switch ON
SFR (A22-1) — GND (A22-9)	10 – 14	IG switch ON, ABS warning light OFF
SFL (A20-13) — GND (A20-25)	10 – 14	IG switch ON, ABS warning light OFF
SRR (A20-26) — GND (A20-25)	10 – 14	IG switch ON, ABS warning light OFF
SRL (A22-7) — GND (A22-9)	10 – 14	IG switch ON, ABS warning light OFF
AST (A20-21) — GND (A20-25)	10 – 14	IG switch ON, ABS warning light OFF
SMC (A22-2) — GND (A22-9)	10 – 14	IG switch ON, TRAC and TRAC OFF indicator light OFF
SRC (A22-8) — GND (A22-9)	10 – 14	IG switch ON, TRAC and TRAC OFF indicator light OFF
WA (A22-5) — GND (A22-4)	Below 2.0	IG switch ON, ABS warning light ON
	10 – 14	IG switch ON, ABS warning light OFF
PKB (A22-12) — GND (A22-4)	Below 1.5	IG switch ON, PKB switch ON Fluid in M/C reservoir above MIN level.
	10 – 14	IG switch ON, PKB switch OFF Fluid in M/C reservoir above MIN level.
LBL (A20-10) — GND (A20-25)	10 – 14	IG switch ON Fluid in M/C reservoir above MIN level.
	Below 1.5	Stop light switch OFF
STP (A22-6) — GND (A22-4)	8 – 14	Stop light switch ON
	10 – 14	IG switch ON, ABS warning light OFF
D/G (A22-10) — GND (A22-9)	10 – 14	IG switch ON, ABS warning light OFF

Symbols (Terminal No.)	STD Voltage (V)	Conditions
Tc (A20-23) - GND (A20-25)	10 - 14	IG switch ON
Ts (A20-11) - GND (A20-25)	10 - 14	IG switch ON
FR+ (A20-17) - FR- (A20-4)	10 - 14	IG switch ON Slowly turn right front wheel.
FL+ (A20-5) - FL- (A20-18)	AC generation	IG switch ON Slowly turn left front wheel.
RR+ (A21-2) - RR- (A21-10)	AC generation	IG switch ON Slowly turn right rear wheel.
RL+ (A21-9) - RL- (A21-1)	AC generation	IG switch ON Slowly turn left rear wheel.
FRO (A21-13) - GND (A22-4)	Pulse generation	IG switch ON Slowly turn right front wheel.
FLO (A21-15) - GND (A22-4)	Pulse generation	IG switch ON Slowly turn left front wheel.
RRO (A21-6) - GND (A22-4)	Pulse generation	IG switch ON Slowly turn right rear wheel.
RLO (A21-4) - GND (A22-4)	Pulse generation	IG switch ON Slowly turn left rear wheel.
GS 1 (A20-8) - GND (A20-25)	4 - 6 or 7 - 11	IG switch ON, Vehicle parked on a level surface
GS 2 (A20-20) - GND (A20-25)	4 - 6	IG switch ON, Vehicle parked on a level surface
EXO (A21-12) - GND (A22-4)	10 - 14	IG switch ON

TRAC ECU:

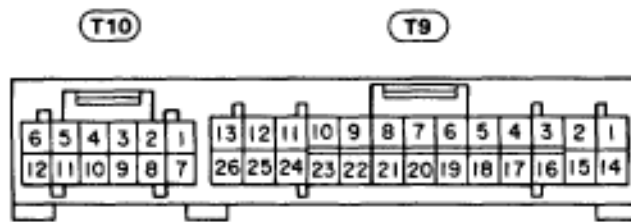

R06997

Symbols (Terminals No.)	STD Voltage (V)	Condition
BAT (T9-12) – GND (T9-14)	10 – 14	Always
BM (T9-13) – GND (T9-14)	10 – 14	Always
IG1 (T9-26) – GND (T9-14)	10 – 14	IG switch ON
ACM (T10-6) – GND (T9-14)	10 – 14	5 seconds after IG switch ON Sub throttle valve fully open
A (T10-4) – GND (T9-14)	10 – 14	5 seconds after IG switch ON Sub throttle valve fully open
\bar{A} (T10-5) – GND (T9-14)	10 – 14	5 seconds after IG switch ON Sub throttle valve fully open
BCM (T10-12) – GND (T9-14)	10 – 14	5 seconds after IG switch ON Sub throttle valve fully open
B (T10-10) – GND (T9-14)	10 – 14	5 seconds after IG switch ON Sub throttle valve fully open
\bar{B} (T10-11) – GND (T9-14)	10 – 14	5 seconds after IG switch ON Sub throttle valve fully open
IDL1 (T10-1) – GND (T9-14)	Below 1.0 10 – 14	Engine idling, Main throttle valve fully closed Engine idling, Main throttle valve fully open
IDL2 (T10-7) – GND (T9-14)	Below 1.0 10 – 14	IG switch ON, Sub throttle valve fully closed IG switch ON, Sub throttle valve fully open
NEO (T9-10) – GND (T9-14)	Pulse generation	Idling
CSW (T9-5) – GND (T9-14)	Below 1.5 10 – 14	IG switch ON, TRAC cut switch pushed in IG switch ON, TRAC cut switch released
PKB (T9-18) – GND (T9-14)	Below 1.5 10 – 14	IG switch ON, PKB switch ON Fluid in M/C reservoir above MIN level IG switch ON, PKB switch OFF Fluid in M/C reservoir above MIN level
IND (T9-24) – GND (T9-14)	10 – 14	IG switch ON, TRAC indicator light ON
WT (T9-23) – GND (T9-14)	Below 2.0 10 – 14	IG switch ON, TRAC OFF indicator light ON IG switch ON, TRAC OFF indicator light OFF
STP (T9-3) – GND (T9-14)	Below 1.5 8 – 14	Stop light switch OFF Stop light switch ON
T_c (T9-11) – GND (T9-14)	10 – 14	IG switch ON
FRO (T9-20) – GND (T9-14)	Pulse generation	IG switch ON Slowly turn right front wheel
FLO (T9-6) – GND (T9-14)	Pulse generation	IG switch ON Slowly turn left front wheel
RRO (T9-19) – GND (T9-14)	Pulse generation	IG switch ON Slowly turn right rear wheel
RLO (T9-7) – GND (T9-14)	Pulse generation	IG switch ON Slowly turn left rear wheel

PROBLEM SYMPTOMS CHART

If a normal code is displayed during the diagnostic trouble code check but the problem still occurs, check the circuits for each problem symptom in the order given in the table below and proceed to the relevant troubleshooting page.

Symptoms	Inspection Circuit	See page
TRAC does not operate.	<p>Only when 1. ~ 5, are all normal and the problem is still occurring, replace the TRAC ECU.</p> <ol style="list-style-type: none"> 1. Check the diagnostic trouble code, reconfirming that the Normal code is output 2. IG power source circuit. 3. Check the hydraulic circuit for leakage. 4. Speed sensor circuit. 5. Park/neutral position switch circuit. 	<p>BR-126</p> <p>BR-142</p> <p>BR-165</p> <p>BR-138</p> <p>AT1-81 or AT2-101</p>
TRAC indicator light abnormal.	<ol style="list-style-type: none"> 1. TRAC indicator light circuit. 2. TRAC ECU. 	BR-162
TRAC OFF indicator light abnormal.	<p>Only when 1. and 2. are all normal and the problem is still occurring, replace the TRAC ECU.</p> <ol style="list-style-type: none"> 1. TRAC OFF indicator light circuit. 2. TRAC cut switch circuit. 	<p>BR-159</p> <p>BR-159</p>
Diagnostic trouble code check cannot be performed.	<p>Only when 1. and 2, are all normal and the problem is still occurring, replace the TRAC ECU.</p> <ol style="list-style-type: none"> 1. TRAC indicator light circuit 2. Tc terminal circuit. 	<p>BR-162</p> <p>BR-163</p>

CIRCUIT INSPECTION

DTC 24 TRAC Sub-Throttle Actuator Circuit

CIRCUIT DESCRIPTION

The sub-throttle actuator operates in accordance with signals from the ECU, controlling the opening and closing of the sub-throttle valve.

DTC No.	Diagnostic Trouble Code Detecting Condition	Trouble area
24	Open or short in sub-throttle actuator circuit.	<ul style="list-style-type: none"> • TRAC fuse • Open or short in BM circuit. • Sub-throttle actuator. • Open or short in sub-throttle actuator circuit. • ECU

WIRING DIAGRAM

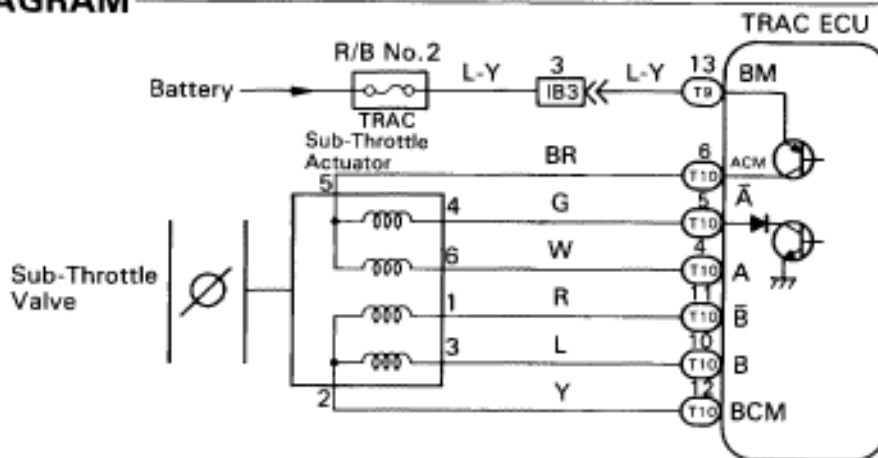

R07197

INSPECTION PROCEDURE

1

Check TRAC fuse.

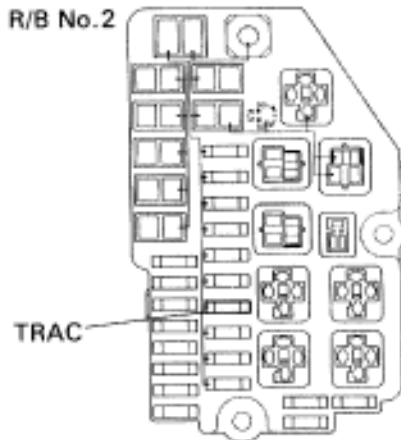

- P** Remove TRAC fuse from R/B No.2.
- C** Check continuity of TRAC fuse.
- OK** Continuity

OK

NG

Check for short in all harness and components connected to TRAC fuse.

2

Check voltage between terminals BM and GND of TRAC ECU.

LOCK

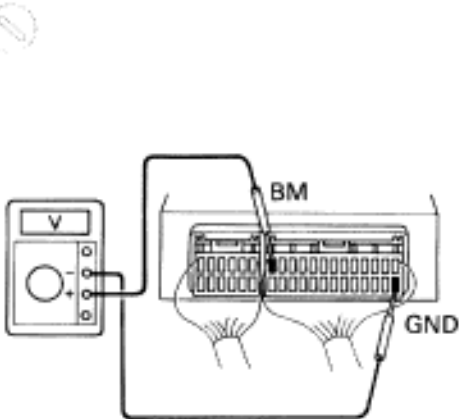

- P** Remove TRAC ECU with connectors still connected.
- C** Measure voltage between terminals BM and GND of TRAC ECU.
- OK** Voltage: 10 – 14 V

OK

NG

Check and repair harness or connector.

3 Check sub-throttle actuator.

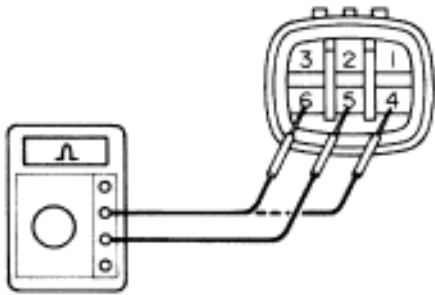

The illustration shows checking for continuity between 4 – 5, and 5 – 6.

R06189

P Disconnect sub-throttle actuator connector.

C Check continuity between each terminal of sub-throttle actuator connector shown below.

OK	Terminals 1 and 2	Continuity (Reference value 0.9)
	Terminals 2 and 3	
	Terminals 4 and 5	
	Terminals 5 and 6	

OK

NG Replace sub-throttle actuator.

4 Check for open and short in harness and connector between TRAC ECU and sub-throttle actuator (See page [IN-30](#)).

OK

NG Repair or replace harness or connector.

Check and replace TRAC ECU.

DTC 25 26 TRAC Sub-Throttle Valve

DTC No.	Diagnostic Trouble Code Detecting Condition	Trouble area
25	The difference between the sub-throttle sensor signal voltage and the voltage required by the step count is 1 V or more.	Sub-throttle actuator. Throttle body (sub-throttle valve is stuck or operation is faulty). Sub-throttle position sensor. Open or short in sub-throttle position sensor circuit. ECM TRAC ECU
26	Even when sub-throttle valve is driven to the fully open position, input voltage at terminal VTA2 of ECM does not come within range of the specifications 3-4.5 V.	Sub-throttle actuator. Throttle body (sub-throttle valve is stuck or operation is faulty). Sub-throttle position sensor. Open or short in sub-throttle position sensor circuit. ECM TRAC ECU



- P** Remove air duct.
- C** Open and close the sub-throttle valve manually and check the condition during operation.
- OK** **The valve should operate smoothly without catching.**

HINT: If sub throttle actuator, sub-throttle valve, sub-throttle position sensor and harness are free from any defect, ECM may be defective.

If ECM is free from any defect, TRAC ECU may be defective.

DTC 31 32 33 34 Speed Sensor Circuit

CIRCUIT DESCRIPTION

The speed sensor detects the wheel speed and sends the appropriate signals to the ECU. These signals are used to control both the ABS and TRAC control systems. The front and rear rotors each have 48 serrations. When the rotors rotate, the magnetic field emitted by the permanent magnet in the speed sensor generates an AC voltage. Since the frequency of this AC voltage changes in direct proportion to the speed of the rotor, the frequency is used by the ECU to detect the speed of each wheel.

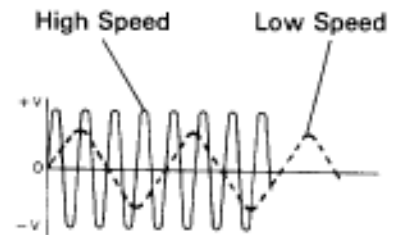
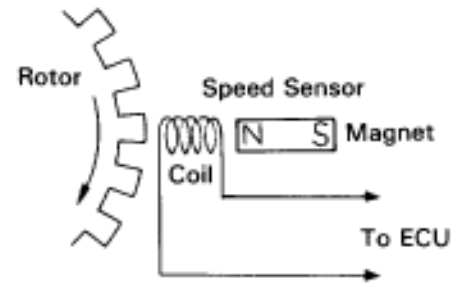

BR3583
BR3582

DTC No.	Diagnostic Trouble Code Detecting Condition	Trouble area
31, 32 33, 34	Detection of any of conditions (1) through (3): (1) At vehicle speed of 10 km/h (6 mph) or more, pulses are not input for 5 sec. (2) Momentary interruption of the vehicle speed sensor signal occurs at least 7 times in the time between switching the ignition switch ON and switching it OFF. (3) Abnormal fluctuation of speed sensor signals with the vehicle speed 20 km/h (12 mph) or more.	<ul style="list-style-type: none"> • Right front, left front, right rear and left rear speed sensor. • Open or short in each speed sensor circuit. • ECU

HINT: DTC No.31 is for the right front speed sensor.
 DTC No.32 is for the left front speed sensor.
 DTC No.33 is for the right rear speed sensor.
 DTC No.34 is for the left rear speed sensor.

WIRING DIAGRAM

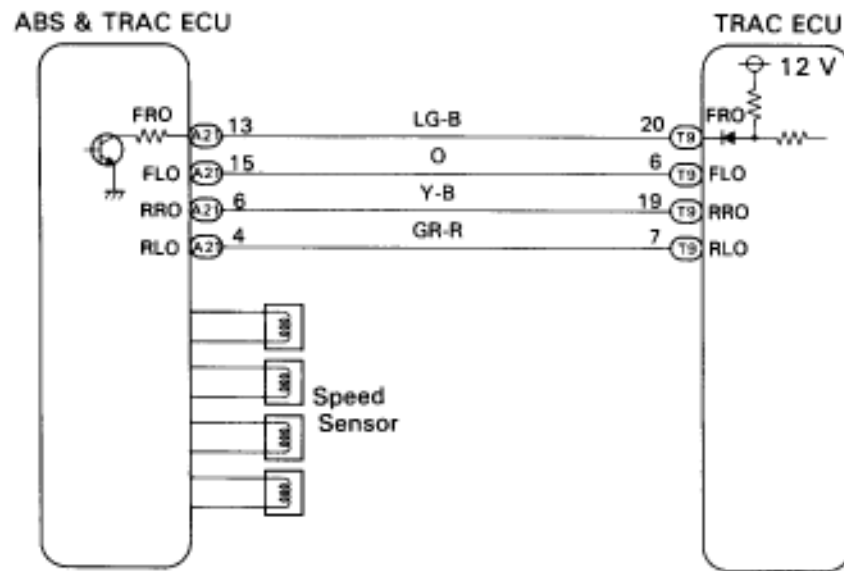

INSPECTION PROCEDURE

HINT: If the same code is output from the ABS warning light, troubleshoot the ABS first.

1

Check for open and short in harness and connector between terminals FRO, FLO, RRO, RLO of ABS & TRAC ECU and TRAC ECU (See page [IN-30](#)).

OK

NG

Repair or replace harness or connector.

2

Check speed sensor.

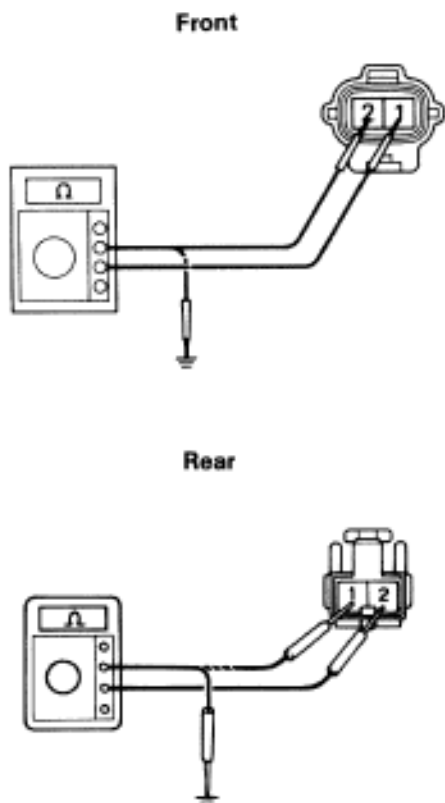

Front

- P** 1. Remove front fender splash shield.
2. Disconnect speed sensor connector.

C Measure resistance between terminals 1 and 2 of speed sensor connector.

OK Resistance: 0.7 – 1.7 k

C Measure resistance between terminals 1 and 2 of speed sensor connector and body ground.

OK Resistance: 1 M or higher

Rear

- P** 1. Remove rear seat cushion, seat back and quarter trim panel.
2. Disconnect speed sensor connector.

C Measure resistance between terminals 1 and 2 of speed sensor connector.

OK Resistance: 0.7 – 1.7 k

C Measure resistance between terminals 1 and 2 of speed sensor connector and body ground.

OK Resistance: 1 M or higher

OK

NG

Replace speed sensor.

NOTICE: Check the speed sensor signal last (See page [BR-62](#)).

3

Check for open and short in harness and connector between each speed sensor and ECU (See page [IN-30](#)).

OK

NG

Repair and replace harness or connector.

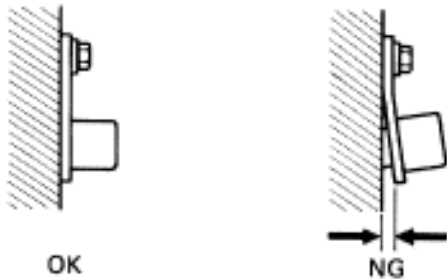
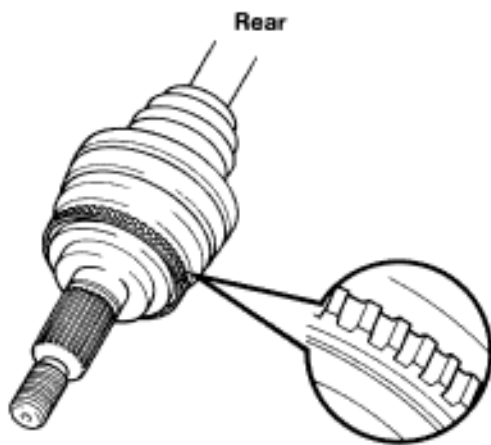
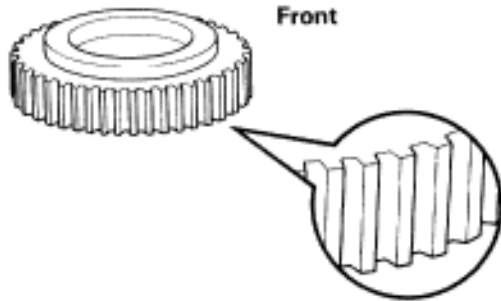
4**Check sensor rotor and sensor installation.**BR3719
BR3720
BR3795**Front**

- P** Remove front speed sensor rotor (See page [SA-15](#)).
- C** Check sensor rotor serrations.
- OK** No scratches or missing teeth.
- C** Check the front speed sensor installation.
- OK** The installation bolt is tightened properly.

Rear

- P** Remove the drive shaft (See page [SA-45](#)).
- C** Check the sensor rotor serrations.
- OK** No scratches or missing teeth.
- C** Check the rear speed sensor installation.
- OK** The installation bolt is tightened properly and there is no clearance between the sensor and rear axle carrier.

OK**NG**

Replace speed sensor or rotor.

NOTICE: Check the speed sensor signal last (See page [BR-62](#)).

Check and replace ABS (& TRAC) ECU.

DTC 41 IG Power Source Circuit CIRCUIT DESCRIPTION

This is the power source for the ECU, hence the CPU and the actuators.

DTC No.	Diagnostic Trouble Code Detecting Condition	Trouble area
41	When either of the following (1) or (2) is detected: (1) Voltage at ECU terminal IG1 is less than 9.5 V for more than 10 sec. while engine speed is 500 RPM or higher. (2) Voltage at ECU terminal IG1 is more than 17 V for more than 5 sec.	Battery IC regulator Open or short in power source circuit ECU

WIRING DIAGRAM

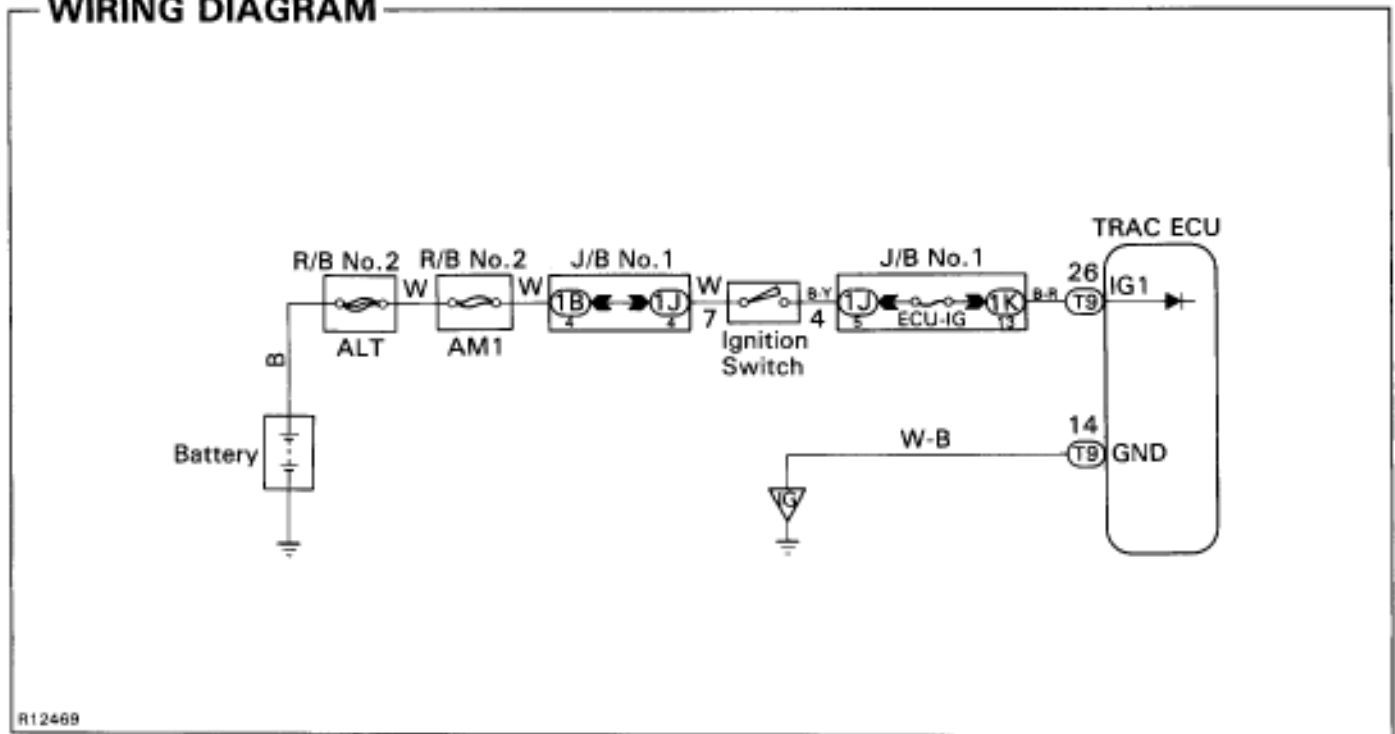

INSPECTION PROCEDURE

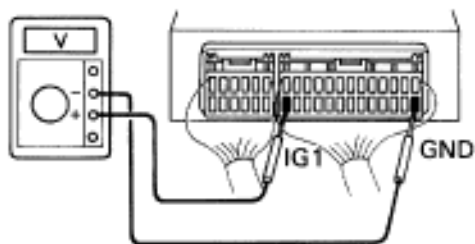
1 Check battery positive voltage.**OK** Voltage: 10 – 14 V**OK****NG** Check and repair the charging system.**2** Check voltage between terminals IG1 and GND of TRAC ECU connector.ON
BE6653
RO6987

- P** 1. Remove TRAC ECU with connectors still connected.
2. Turn ignition switch ON.

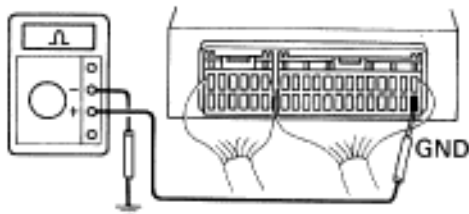
C Measure voltage between terminals IG1 and GND of TRAC ECU connector.**OK** Voltage: 10 – 14 V**NG****OK** Check and replace TRAC ECU.**3** Check continuity between terminal GND of TRAC ECU connector and body ground.LOCK
BE6653
RO6988**C** Measure resistance between terminal GND of TRAC ECU connector and body ground.**OK** Resistance: 1 Ω or less**OK****NG** Repair or replace harness or connector.

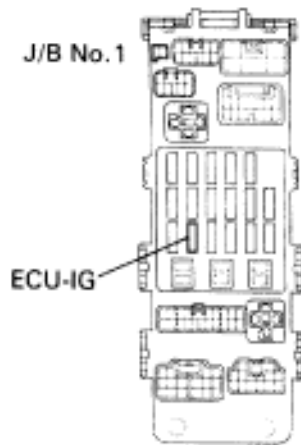
4**Check ECU-IG fuse.**

R07407

P Remove ECU-IG fuse from J/B No. 1.**C** Check continuity of ECU-IG fuse.**OK** Continuity**OK****NG**

Check for short in all the harness and components connected to ECU-IG fuse.

Check for open in harness and connector between TRAC ECU and battery (See page [IN-30](#)).

DTC 43 ABS & TRAC ECU Malfunction

CIRCUIT DESCRIPTION

DTC No.	Diagnostic Trouble Code Detecting Condition	Trouble area
43	ABS control system or TRAC (BRAKE) control system or communication circuit is abnormal.	ABS & TRAC ECU Open or short in BRFA circuit

WIRING DIAGRAM

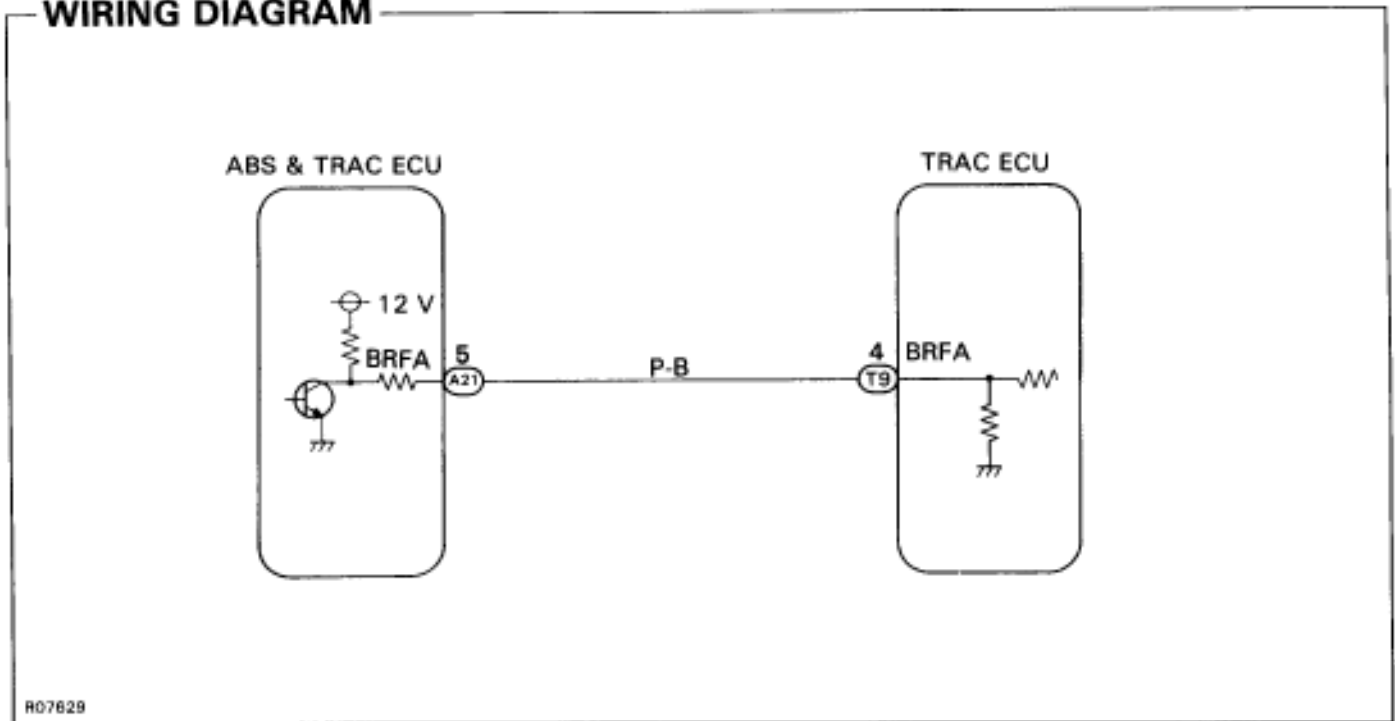

INSPECTION PROCEDURE

1

Is diagnostic trouble code output for the ABS & TRAC (BRAKE)?

Perform diagnostic trouble code check on page [BR-128](#).

NO

YES

Repair circuit indicated by the code output.

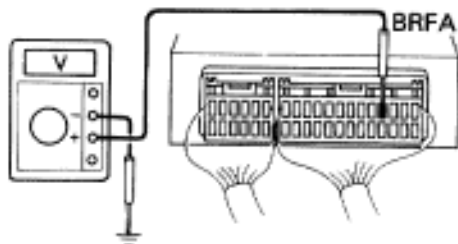
2**Check voltage between terminal BRFA of TRAC ECU and body ground.**
 ON
BE6653
R06989

- P** 1. Remove TRAC ECU with connectors still connected.
2. Turn ignition switch ON.

C Measure voltage between terminal BRFA of TRAC ECU and body ground.

OK Voltage: About 6 V (Pulse)

(Reference)

6 – 14 V

1 V or less

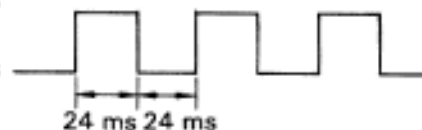
 NG

 OK

Check and replace TRAC ECU.

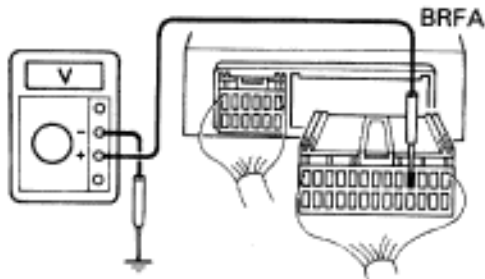
3**Check voltage between terminal BRFA of TRAC ECU and body ground with TRAC ECU connector disconnected.**
 ON
BE6653
R07627

P Disconnect TRAC ECU connector.

C Measure voltage between terminal BRFA of TRAC ECU connector and body ground.

HINT: Measure voltage within 8 seconds from the time TRAC ECU connector is disconnected.

OK Voltage: See step 1.

 NG

 OK

Check and replace TRAC ECU.

4**Check for open and short in harness and connector between ABS & TRAC ECU and TRAC ECU (See page IN-30).**
 OK

 NG

Repair or replace harness or connector.

Check and replace ABS & TRAC ECU.

DTC 44 NE Signal Circuit

CIRCUIT DESCRIPTION

The TRAC ECU receives engine speed signals (NEO signals) from the ECM.

DTC No.	Diagnostic Trouble Code Detecting Condition	Trouble area
44	No signal is input to terminal NEO 0.24 sec. after traction control is initiated.	Open or short in NEO circuit ECM TRAC ECU

WIRING DIAGRAM

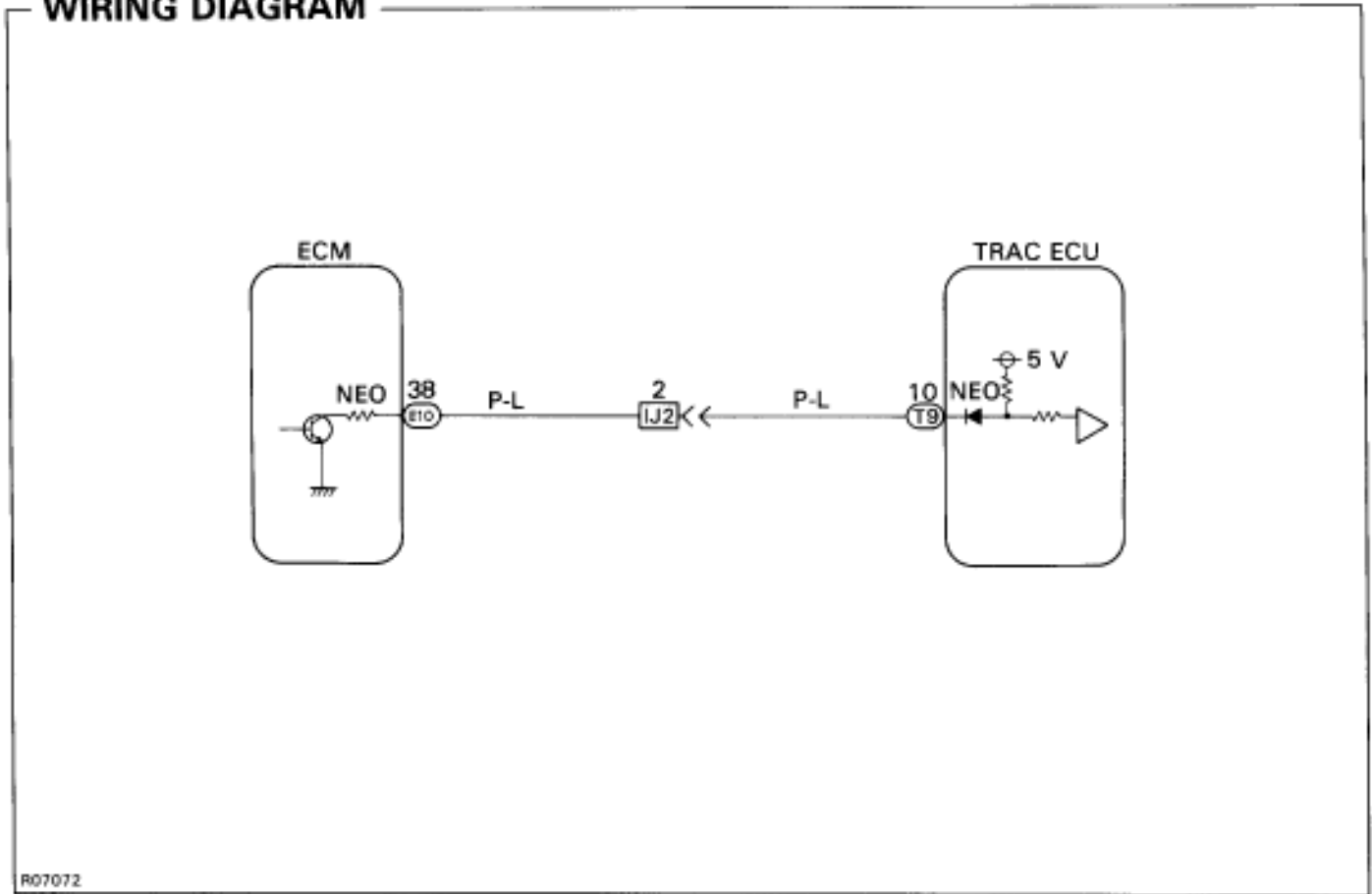

R07072

INSPECTION PROCEDURE

1

Check for open and short in harness and connector between terminal NEO of TRAC ECU and terminal NEO of ECM (See page [IN-30](#)).

OK

NG

Repair or replace harness or connector.

2

Check voltage between terminal NEO of TRAC ECU and body ground.



ON

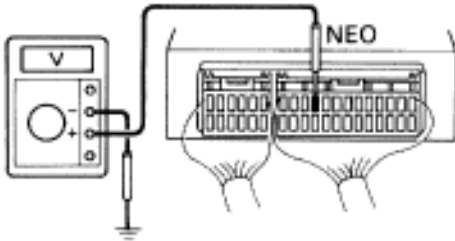

BE6653
R08990

P

1. Remove TRAC ECU with connectors still connected.
2. Turn ignition switch ON.

C

Measure voltage between terminal NEO of TRAC ECU and body ground for the engine conditions below

OK

Engine condition	Voltage
OFF (IG ON)	4 – 6 V or Below 1 V
ON (Idling)	2 – 3 V (Pulse)

OK

NG

Check and replace TRAC ECU or ECM.

If the same code is still output after the diagnostic code is deleted, check the contact condition of each connection.

DTC 45 46 Main Throttle Position Sensor Circuit CIRCUIT DESCRIPTION

This circuit is not directly related to the TRAC control, but as it has an influence on TRAC control when trouble occurs in this circuit, it is used to switch off the TRAC system as a fail safe function.

DTC No.	Diagnostic Trouble Code Detecting Condition	Trouble area
45	Conditions (1) and (2) continue for 0.31 sec.: (1) CTP switch of main throttle position sensor is ON. (2) Input voltage of ECM terminal VTA1: 1.5 V or more.	Main throttle position sensor Short in IDL1 circuit ECM TRAC ECU
46	Either of the following (1) or (2) continues for 0.6 sec.: (1) Input voltage of ECM terminal VTA1: 4.9 V or more. (2) Input voltage of ECM terminal VTA1: 0.1 V or less.	Main throttle position sensor Open or short in VTA1 circuit ECM

WIRING DIAGRAM

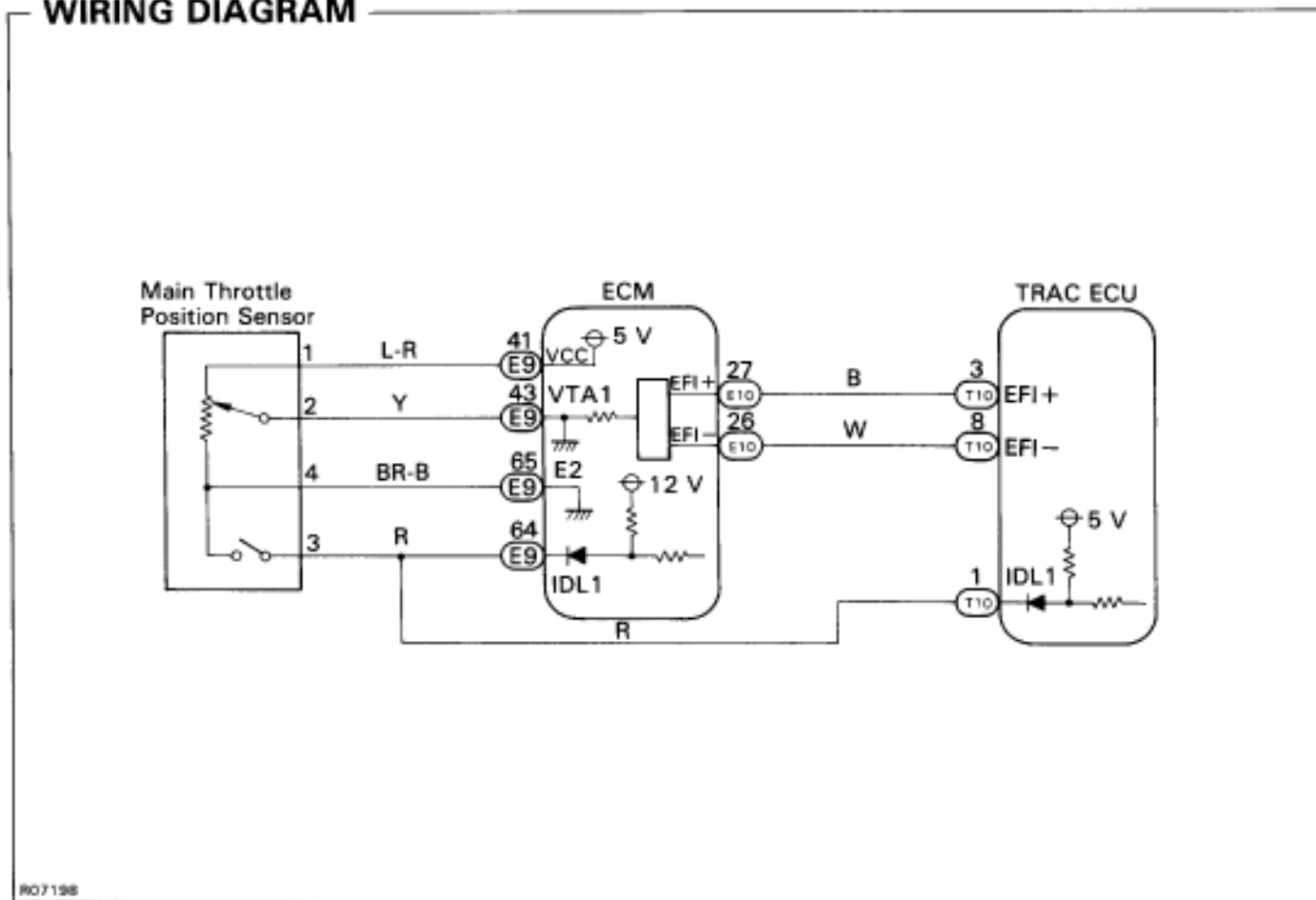

INSPECTION PROCEDURE

HINT: The main throttle position sensor signal is transmitted to the TRAC ECU from ECM, so if an error occurs at the engine side, the TRAC ECU also detects it.

If diagnostic trouble code No.41 is being output for the engine troubleshoot the engine first.

1 Is diagnostic trouble code output for the engine?

Do diagnostic trouble code check on page [EG-491](#).

NO

YES Repair circuit indicated by the code output.

2 Check voltage between terminal IDL1 of TRAC ECU and body ground.

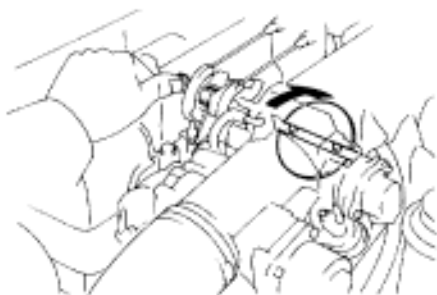

 ON

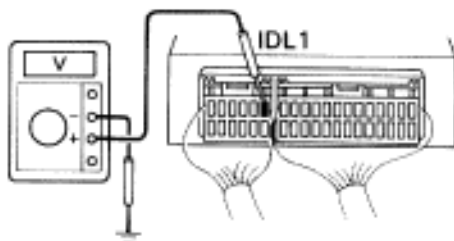

R06991
BE0653
R06992

- P**
1. Remove TRAC ECU with connectors still connected.
 2. Disconnect the vacuum hose from the throttle opener, and apply the vacuum to the throttle opener.
 3. Turn ignition switch ON.

C Measure voltage between terminal IDL1 of TRAC ECU and body ground, when the main throttle valve is fully closed and fully open.

OK

Main throttle valve position	Voltage
Fully closed	Below 1.0 V
Fully open	10 – 14 V

NG

OK Go to step **6**.

3

Check for open and short in harness and connector between terminal IDL1 of TRAC ECU and main throttle position sensor with TRAC ECU, ECM and main throttle position sensor connectors disconnected (See page [IN-30](#)).

OK

NG

Repair or replace harness or connector.

4

Check for short in harness between terminal IDL1 of TRAC ECU and body ground with only main throttle position sensor connector connected (See page [IN-30](#)).

OK

NG

Check and replace main throttle position sensor.

5

Check for short in harness between terminal IDL1 of TRAC ECU and body ground with only ECM connector connected (See page [IN-30](#)).

OK

NG

Check and replace ECM.

Check and replace TRAC ECU.

6

Check voltage of terminal VTA1 of ECM (See page [EG-554](#)).

NG

OK

Check and replace ECM.

7

Check for open and short in harness and connector between terminal VTA1 of ECM and main throttle position sensor (See page [IN-30](#)).

OK

NG

Repair or replace harness or connector.

8

Check main throttle position sensor (See page [EG-555](#)).

OK

NG

Adjust or replace main throttle position sensor
See page [EG-292](#).

Check and replace ECM.

DTC 47 48 Sub-Throttle Position Sensor Circuit CIRCUIT DESCRIPTION

This sensor detects the opening angle of the sub-throttle valve and sends the appropriate signals to the ECU. If a trouble signal is input, the ECU prohibits TRAC control.

DTC No.	Diagnostic Trouble Code Detecting Condition	Trouble area
47	When any of the following (1) through (3) is detected: (1) Deviation of 5 steps or more to the closed side of the idle step during sub-throttle initial check. (2) Voltage at terminal IDL2 does not become 0 V even after sub-throttle is driven to fully closed position during sub-throttle initial check. (3) Voltage at terminal VTA2 of ECM is 1.5 V or more for at least 0.31 sec. while CTP switch is ON.	Sub-throttle position sensor Open or short in IDL2 circuit ECM TRAC ECU
48	Either of the following (1) or (2) continues for at least 0.26 sec.: (1) Input voltage of ECM terminal VTA2: 4.9 V or more (2) Input voltage of ECM terminal VTA2: 0.1 V or less.	Sub-throttle position sensor Open or short in VTA2 circuit ECM

WIRING DIAGRAM

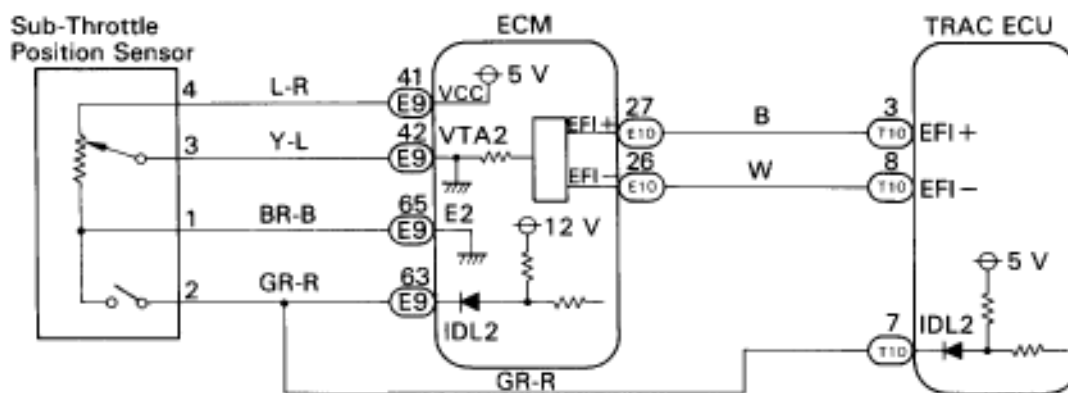

INSPECTION PROCEDURE

HINT: The sub-throttle position sensor signal is transmitted to the TRAC ECU from ECM, so if an error occurs at the engine side, the TRAC ECU also detects it.

If diagnostic trouble code No. 47 is being output for the engine, troubleshoot the engine first.

1 Is diagnostic trouble code output for the engine?

Do diagnostic trouble code check on page [EG-491](#).

NO

YES Repair circuit indicated by the code output.

2 Check voltage between terminal IDL2 of TRAC ECU and body ground.

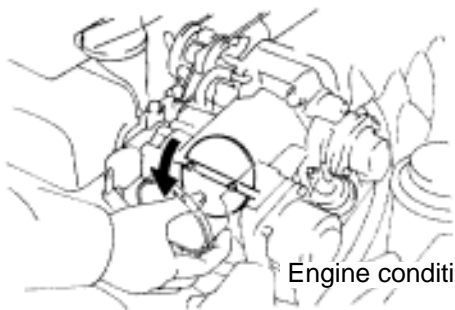

ON

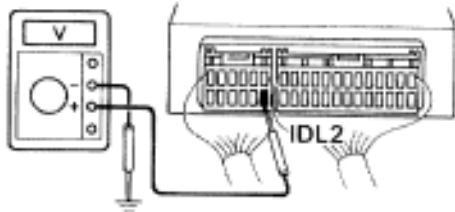

- P**
1. Remove TRAC ECU with connectors still connected.
 2. Remove intake air duct.
 3. Disconnect step motor connector.
 4. Turn ignition switch ON.

C Measure voltage between terminal IDL2 of TRAC ECU and body ground, when the sub-throttle valve is fully closed and fully open.

OK

Sub-throttle valve position	Voltage
Fully closed	Below 1.0 V
Fully open	10 – 14 V

R06966
SE6653
R06993

NG

OK Go to step 6.

3

Check for open and short in harness and connector between terminal IDL2 of TRAC ECU and main throttle position sensor with TRAC ECU, ECM and main throttle position sensor connectors disconnected (See page [IN-30](#)).

OK

NG

Repair or replace harness or connector.

4

Check for short in harness between terminal IDL2 of TRAC ECU and body ground with only main throttle position sensor connector connected (See page [IN-30](#)).

OK

NG

Check and replace main throttle position sensor.

5

Check for short in harness between terminal IDL2 of TRAC ECU and body ground with only ECM connector connected (See page [IN-30](#)).

OK

NG

Check and replace ECM.

Check and replace TRAC ECU.

6

Check voltage of terminal VTA2 of ECM (See page [EG-554](#)).

NG

OK

Check and replace ECM.

7

Check for open and short in harness and connector between terminal VTA2 of ECM and main throttle position sensor (See page [IN-30](#)).

OK

NG

Repair or replace harness or connector.

8

Check main throttle position sensor (See page [EG-555](#)).

OK

NG

Adjust or replace main throttle position sensor
See page [EG-294](#).

Check and replace ECM.

DTC 51 Engine Malfunction Detection Circuit

CIRCUIT DESCRIPTION

If trouble in the engine control system causes the malfunction indicator light to light up, this information is transmitted from the ECM to the TRAC ECU. The TRAC ECU may prohibit TRAC control as a result.

DTC No.	Diagnostic Trouble Code Detecting Condition	Trouble area
51	Conditions (1) and (2) continue for more than 1 sec.: (1) Engine speed: 500 rpm or more (2) Malfunction information is input from the ECM.	Engine control system

INSPECTION PROCEDURE

1	Check the diagnostic trouble code for the engine (See page EG-491).				
	Malfunction indicator light remains ON.	<table border="1" style="display: inline-table; vertical-align: middle;"> <tr> <td style="text-align: center;">Output NG code</td> <td style="font-size: 2em; vertical-align: middle;">}</td> <td>Repair engine control system according to the code output.</td> </tr> </table>	Output NG code	}	Repair engine control system according to the code output.
Output NG code	}	Repair engine control system according to the code output.			
Check for short in all the harness and ECU connected to malfunction indicator light.					

DTC 53 ECM Communication Circuit Malfunction

CIRCUIT DESCRIPTION

This circuit is used to send TRAC control information from the TRAC ECU to the ECM (TRC+, TRC-), and engine control information from the ECM to the TRAC ECU (EFI+, EFI-).

DTC No.	Diagnostic Trouble Code Detecting Condition	Trouble area
53	<p>Either of the following (1) or (2) continues for 5 sec.:</p> <p>(1) A signal is received from the ECM indicating trouble in the TRC+ or TRC- circuit.</p> <p>(2) No EFI ± data is received from the ECM when the engine speed is 500 RPM or more, or the vehicle speed is 60 km/h (37 mph) or more.</p>	<p>Open or short in TRC+ or TRC- circuit</p> <p>Open or short in EFI+ or EFI- circuit</p> <p>ECM</p> <p>TRAC ECU</p>

WIRING DIAGRAM

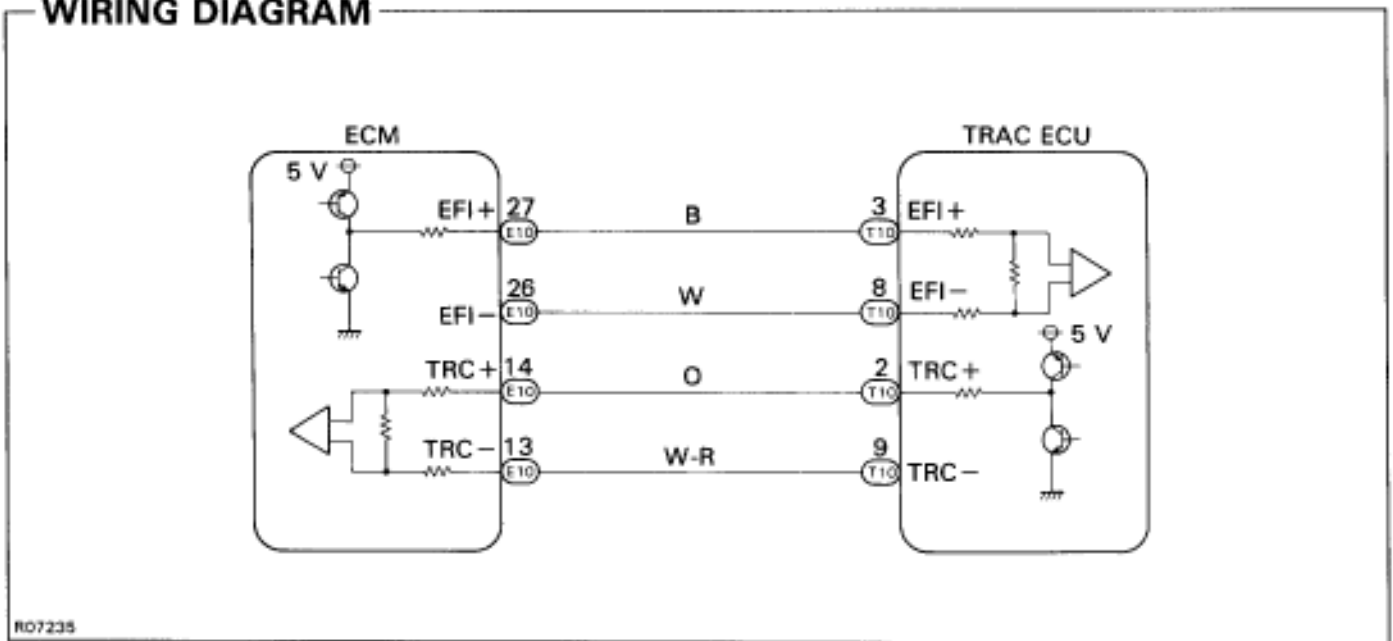

R07235

INSPECTION PROCEDURE

HINT: When the TRAC indicator light is ON, there is a problem in the EFI ± circuit, and when the TRAC indicator light is OFF, there is a problem in the TRC ± circuit.

1

Check for open and short in harness and connector between terminals EFI+, EFI-, TRAC+ and TRC- of ECU and ECM (See page IN-30).

OK
NG

Repair or replace harness or connector.

Check and replace ECM or TRAC ECU.

DTC 61 ABS & TRAC ECU Communication Circuit Malfunction

CIRCUIT DESCRIPTION

DTC No.	Diagnostic Trouble Code Detecting Condition	Trouble area
61	Malfunction in ABS & TRAC ECU communication circuit.	Open or short in ABSO, BRC, BRP circuit ABS & TRAC ECU TRAC ECU

WIRING DIAGRAM

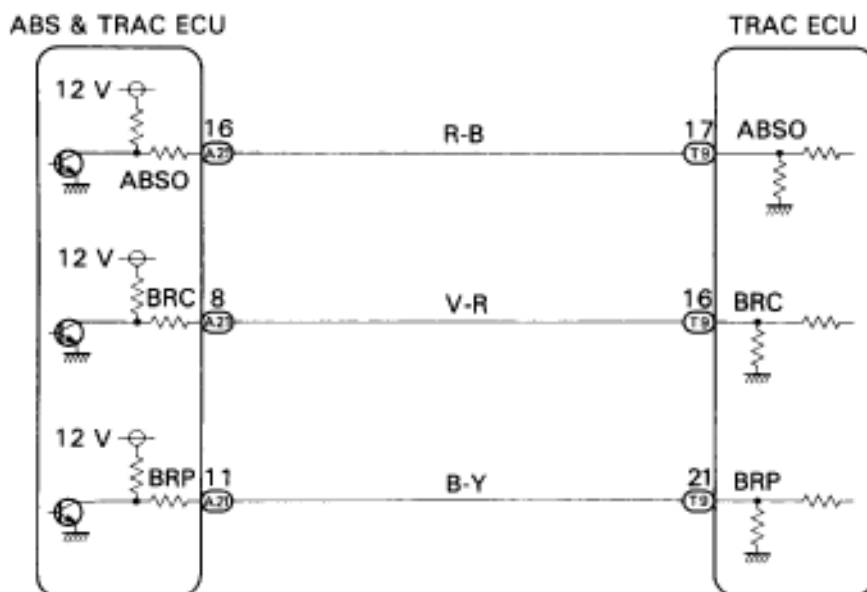

INSPECTION PROCEDURE

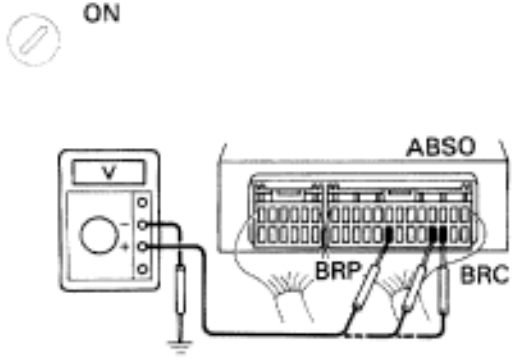
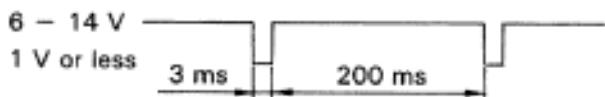
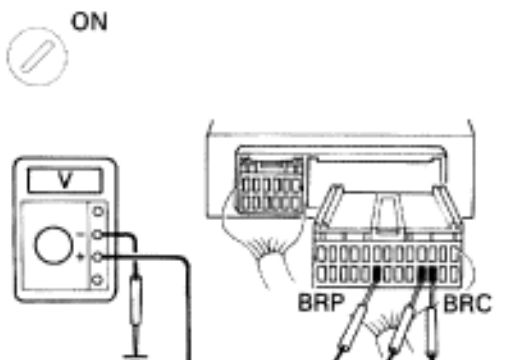
1	Check for open and short in harness and connector between terminals EFI+, EFI-, TRAC+ and TRC- of ECU and ECM (See page IN-30).
	<p>P Remove TRAC ECU with connectors still connected.</p> <p>C Measure voltage between terminals ABSO, BRC, BRP of TRAC ECU and body ground when ignition switch is turned ON.</p> <p>OK Voltage: ABSO, BRC: 6 – 14 V BRP: About 7 V (Pulse) (Reference)</p> 
NG	OK Check and replace TRAC ECU.
2	Check voltage between terminals ABSO, BRC, BRP of TRAC ECU and body ground with TRAC ECU connector disconnected.
	<p>P Disconnect TRAC ECU connector.</p> <p>C Measure voltage between terminals ABSO, BRC, BRP of TRAC ECU and body ground when ignition switch is turned ON.</p> <p>OK Voltage: See step 1.</p>
NG	OK Check and replace TRAC ECU.
3	Check for open and short in harness and connector between ABS & TRAC ECU and TRAC ECU (See page IN-30).
OK	NG Repair or replace harness or connector.

Check and replace ABS & TRAC ECU.

TRAC OFF Indicator TRAC Cut Switch Circuit

CIRCUIT DESCRIPTION

This is the TRAC control main switch. When the TRAC cut switch is pushed on, TRAC control goes off and the TRAC OFF indicator lights up. This indicator is also used for warnings when the trouble occurs.

WIRING DIAGRAM

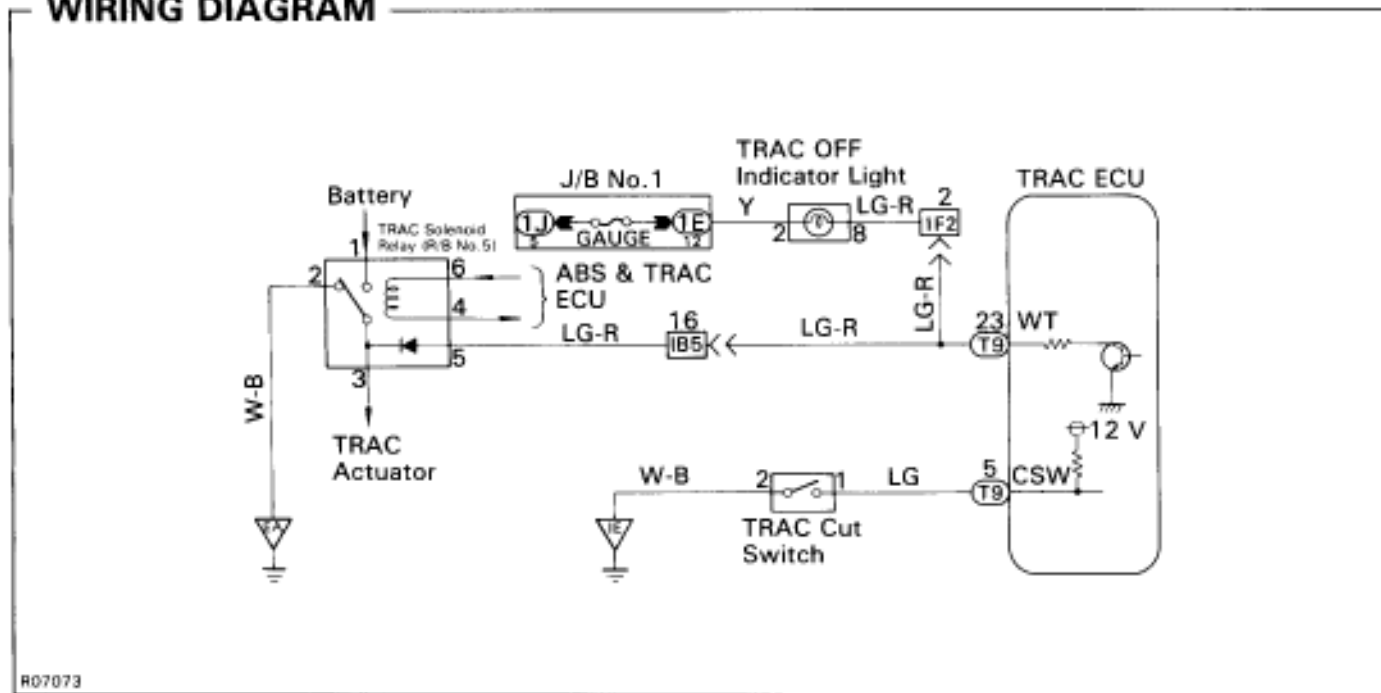

R07073

INSPECTION PROCEDURE

1 Is diagnostic trouble code output?

Do diagnostic trouble code check on page BR 126.

NO

YES Repair circuit indicated by the code output.

2 Check TRAC cut switch.

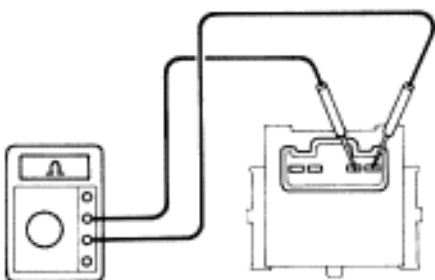

R07082

- P** 1. Remove TRAC cut switch.
2. Disconnect TRAC cut switch connector.

- C** Measure resistance between terminals 1 and 2 of TRAC cut switch when TRAC cut switch is on and off.

OK	TRAC car switch	Resistance
	Pushed in	Continuity
	Released	1 M or higher

OK

NG Replace TRAC cut switch.

3 Check for open and short in harness and connector between terminal CSW of TRAC ECU and TRAC cut switch and body ground (See page IN-30).

OK

NG Repair or replace harness or connector.

4 Check TRAC OFF indicator light.

See Combination Meter Troubleshooting on page BR-43.

OK

NG Repair or replace combination meter.

5 Check TRAC solenoid relay.

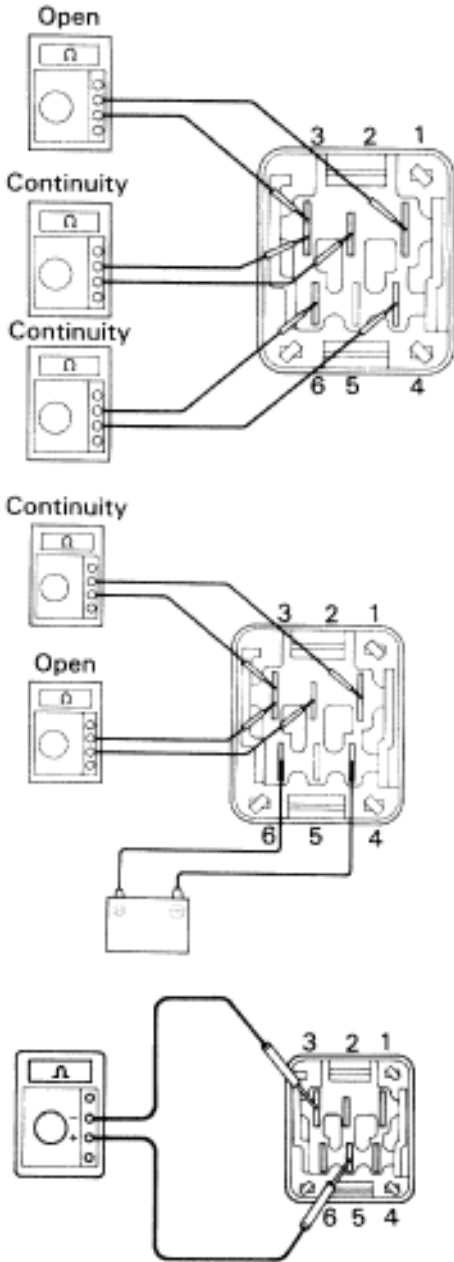

BR5404
BR5405
RO7081

P Remove solenoid relay from R/B No.5.

C Check continuity between each terminal of TRAC solenoid relay shown below.

OK

Terminals 4 and 6	Continuity (Reference value 80 Ω)
Terminals 2 and 3	Continuity
Terminals 1 and 3	Open

C 1. Apply battery positive voltage between terminals 4 and 6.
2. Check continuity between each terminal of TRAC solenoid relay shown below.

OK

Terminals 2 and 3	Open
Terminals 1 and 3	Continuity

C Connect the ⊕ test lead to terminal 5 and the ⊖ lead to terminal 3. Check continuity between the terminals.

OK **Continuity**
If there is no continuity, connect the ⊖ test lead to terminal 5 and the ⊕ lead to terminal 3. Recheck continuity between terminals.

OK

NG Replace TRAC solenoid relay.

6 Check for open and short in harness and connector between terminal WT of TRAC ECU and battery or TRAC solenoid relay (See page IN-30).

OK

NG Repair or replace harness or connector.

Check and replace TRAC ECU.

TRAC Indicator Light Circuit

CIRCUIT DESCRIPTION

The TRAC indicator blinks during TRAC operation.

This indicator is also used for warnings when the trouble occurs and for displaying diagnostic trouble codes.

WIRING DIAGRAM

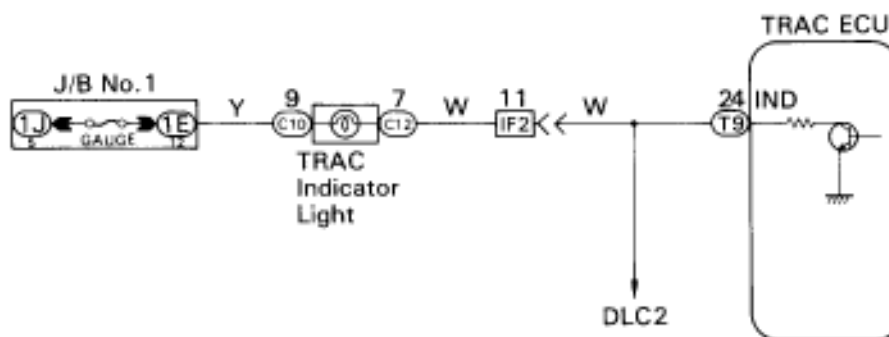

R07074

INSPECTION PROCEDURES

Troubleshoot in accordance with flow chart instructions for each trouble symptom.

TRAC Indicator light does not light up

Go to Combination Meter Troubleshooting on page [BE-43](#).

TRAC Indicator light remains ON

1

Check diagnostic trouble code (See page [BR-126](#)).



Indicator light remains ON

Output
NG Code

Repair circuit indicated by the code output.

2

Check for short in harness and connector between TRAC ECU and TRAC indicator light (See page [IN-30](#)).



OK

NG

Repair or replace harness or connector.

Check and replace TRAC ECU.

INSPECTION PROCEDURE

1

Check voltage between terminals Tc and E1 of DLC2 or DLC1.

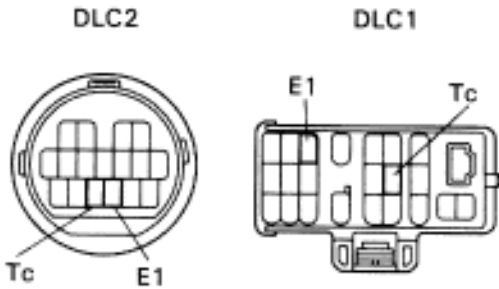

S-17-1
let-23-1-A

- P** Turn ignition switch ON
- C** Measure voltage between terminals Tc and E1 of DLC2 or DLC1.
- OK** Voltage: 10 — 14 V

NG

OK

Proceed to next circuit inspection shown on problem symptoms chart (See page [BR-133](#)).

2

Check for open and short in harness and connector of symptoms connected to Tc terminal (See page [IN-30](#)).

OK

NG

Repair or replace harness or connector.

Check and replace TRAC ECU.

Check for Fluid Leakage

Check for fluid leakage from actuators or hydraulic lines.

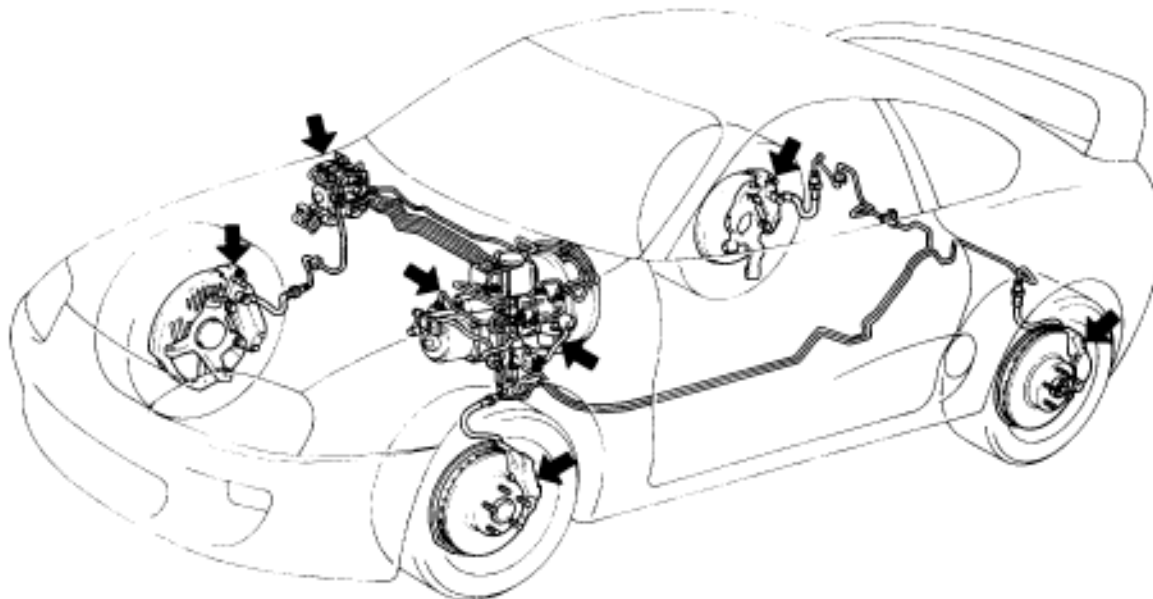

R07201

SERVICE SPECIFICATIONS

SERVICE DATA

Brake pedal height from asphalt sheet		154.2–164.2 mm (6.07–6.46 in.)
Brake pedal freeplay		1–6 mm (0.04–0.24 in.)
Brake pedal reserve distance at 490 N (50 kgf, 110.2 lbf)		
	2JZ–GTE	More than 70 mm (2.76 in.)
	2JZ–GE	More than 72 mm (2.83 in.)
Brake booster push rod to piston clearance w/SST)		0 mm (0 in.)
Front brake pad thickness (2JZ–GTE)	STD	12.0 mm (0.472 in.)
Front brake pad thickness (2JZ–GTE)	Minimum	1.0 mm (0.039 in.)
Front brake pad thickness (2JZ–GE)	STD	11.0 mm (0.433 in.)
Front brake pad thickness (2JZ–GE)	Minimum	1.0 mm (0.039 in.)
Front brake disc thickness (2JZ–GTE)	STD	30.0 mm (1.181 in.)
Front brake disc thickness (2JZ–GTE)	Minimum	28.0 mm (1.102 in.)
Front brake disc thickness (2JZ–GE)	STD	32.0 mm (1.260 in.)
Front brake disc thickness (2JZ–GE)	Minimum	30.0 mm (1.181 in.)
Front brake disc runout	Maximum	0.05 mm (0.0020 in.)
Rear brake disc pad thickness (2JZ–GTE)	Maximum	11.0 mm (0.433 in.)
Rear brake disc pad thickness (2JZ–GTE)	Minimum	1.0 mm (0.039 in.)
Rear brake disc pad thickness (2JZ–GE)	STD	10.0 mm (0.394 in.)
Rear brake disc pad thickness (2JZ–GE)	Minimum	1.0 mm (0.039 in.)
Rear brake disc thickness	STD	16.0 mm (0.630 in.)
Rear brake disc thickness	Minimum	15.0 mm (0.591 in.)
Rear brake disc runout	Maximum	0.05 mm (0.0020 in.)
Rear brake disc inside diameter	STD	190 mm (7.48 in.)
Rear brake disc inside diameter	Maximum	191 mm (7.52 in.)
Parking brake lining thickness	STD	2.5 mm (0.098 in.)
Parking brake lining thickness	Minimum	1.0 mm (0.039 in.)
Parking brake lever travel at 196 N (20 kgf, 44.1 lbf)		5–8 clicks
Parking brake clearance between rear shoe and lever		Less than 0.35 mm (0.012 in.)
Parking brake adjusting shim thickness for rear disc brake		0.3 mm (0.012 in.) 0.6 mm (0.024 in.) 0.8 mm (0.031 in.) 2JZ–GTE only 0.9 mm (0.035 in.) 2JZ–GE only

TORQUE SPECIFICATIONS

Part tightened		N·m	Kgf·cm	ft·lbf
Master cylinder X Piston stopper bolts		10	100	7
Master cylinder X Reservoir		1.7	17.5	15.2 in·lbf
Master cylinder X Brake booster		13	130	9
Brake line union nut	M10	15	155	11
Brake line union nut	M12	20	200	15
Brake booster clevis lock nut		25	260	19
Brake booster X Pedal bracket		13	130	9
Bleeder plug		11	110	8
Front disc brake caliper X Steering knuckle	2JZ-GTE	118	1,200	87
Front disc brake torque plate X Steering knuckle	2JZ-GE	118	1,200	87
Front disc brake caliper installation bolt	2JZ-GE	34	350	25
Front disc brake caliper X Flexible hose union bolt		30	310	22
Rear disc brake caliper X Axle carrier	2JZ-GTE	104	1,065	77
Rear disc brake torque plate X Axle carrier	2JZ-GE	104	1,065	77
Rear disc brake caliper installation bolt	2JZ-GE	34	350	25
Rear disc brake caliper X Flexible hose union bolt		30	310	22
ABS actuator X Actuator bracket		5.4	55	48 in·lbf
ABS actuator X 2-way		8.8	90	78 in·lbf
ABS actuator bracket X Body		19	195	14
Cruise control actuator X Body		19	195	14
Cruise control actuator X ABS actuator X Body		19	195	14
Front speed sensor installation bolt		7.8	80	69 in·lbf
Rear speed sensor installation bolt		7.8	80	69 in·lbf
TRAC actuator bracket X TRAC pump bracket or body		13	130	9
TRAC pump bracket X Body		19	195	14
TRAC pump bracket X Damper		7.8	80	69 in·lbf
TRAC pump bracket X TRAC pump bracket No.2		7.8	80	69 in·lbf
TRAC pump X TRAC pump bracket No.2		7.8	80	69 in·lbf
TRAC pump or damper X Union bolt		46	465	34